

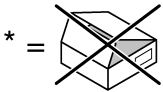

GB13

F13

E14

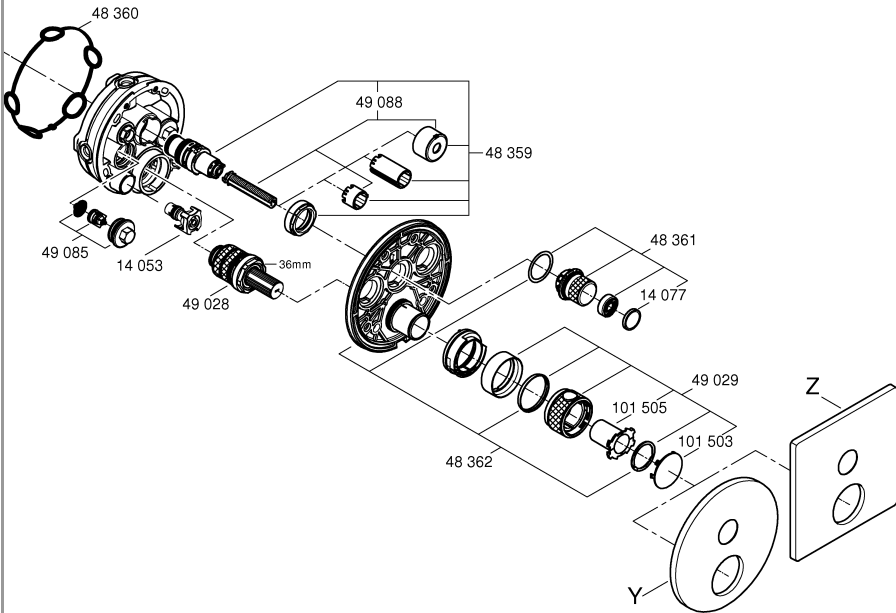

| | |
|---------|------|
| *49 059 | 36mm |
| | |
| *49 003 | |
| | |
| *14 048 | +25 |
| | |

| Y | | Z | |
|--------|--|--------|--|
| 49 044 | | 49 050 | |
| 49 045 | | 49 051 | |



psi

max. 145 72,5
7,25 14,5

bar

max. 10 5
0,5 1

°F

max. 158° 140°

°C

max. 70° 60°

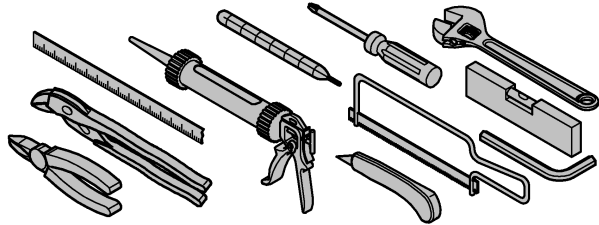
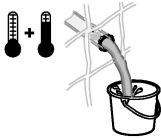

| | | | | | | | |
|-------|------|-----|------|-----|------|------|-----|
| | psi | | | | | | gpm |
| | 14,5 | 29 | 43,5 | 58 | 72,5 | 87 | |
| B / C | 4,4 | 6,3 | 7,7 | 8,8 | 9,9 | 10,8 | |

| | | | | | | | |
|-------|------|------|----|------|------|----|-------|
| | bar | | | | | | l/min |
| | 1 | 2 | 3 | 4 | 5 | 6 | |
| B / C | 16,7 | 23,7 | 29 | 33,5 | 37,4 | 41 | |

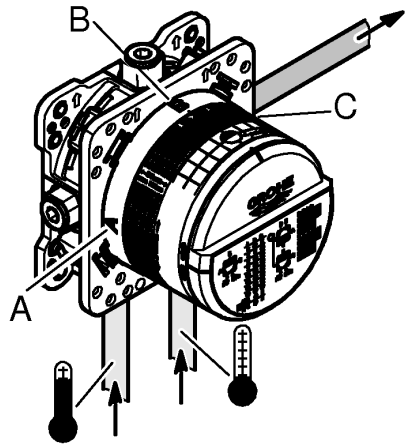
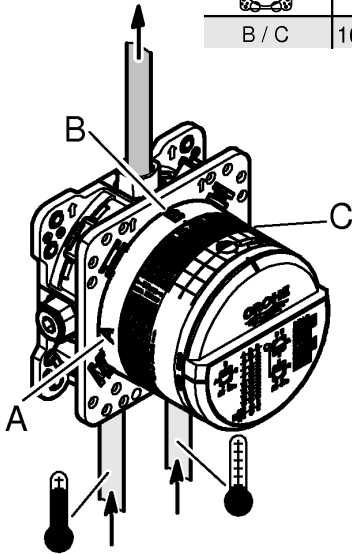



1

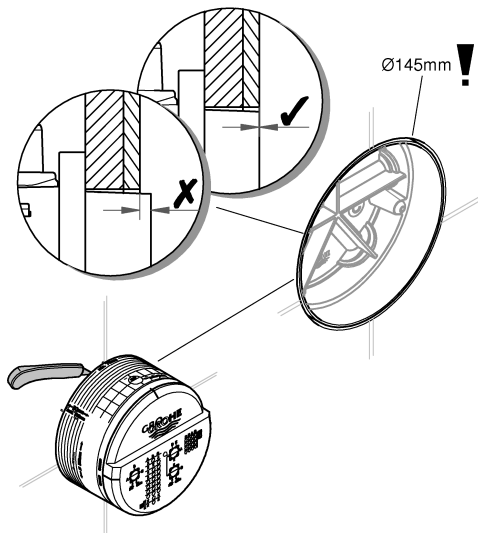
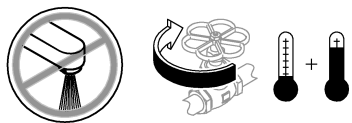

2

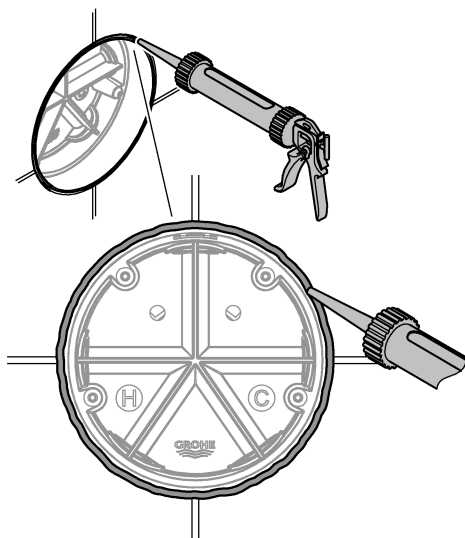

3

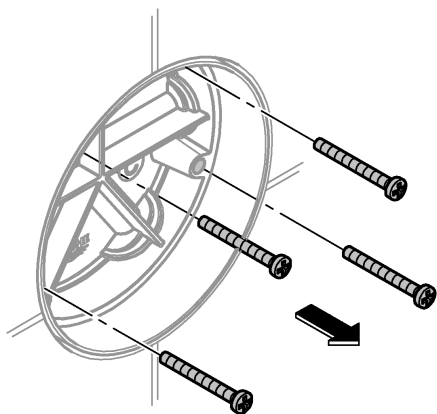

4

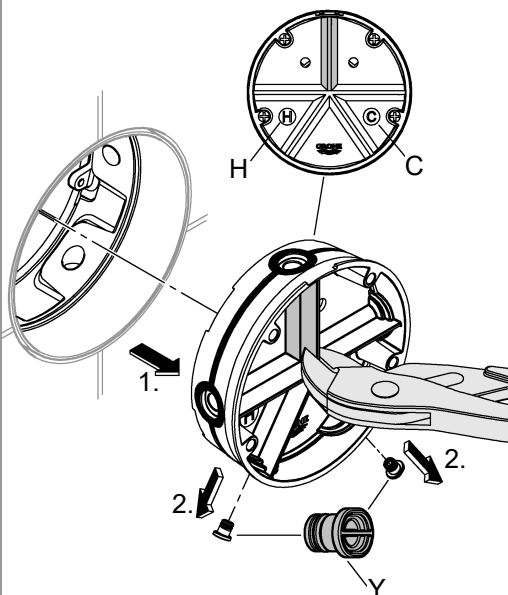



5

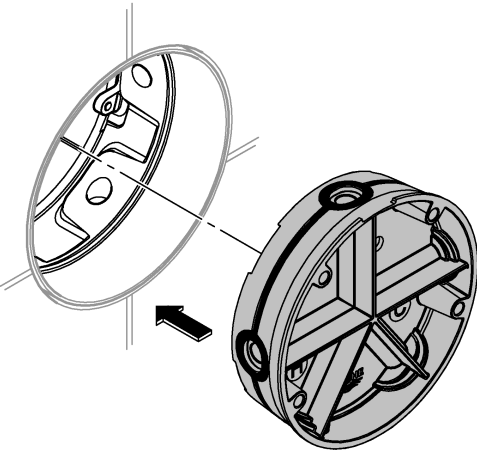

6

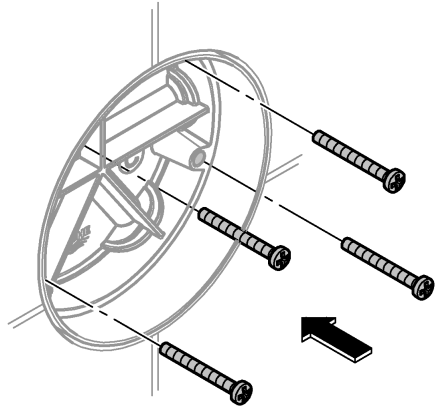

7

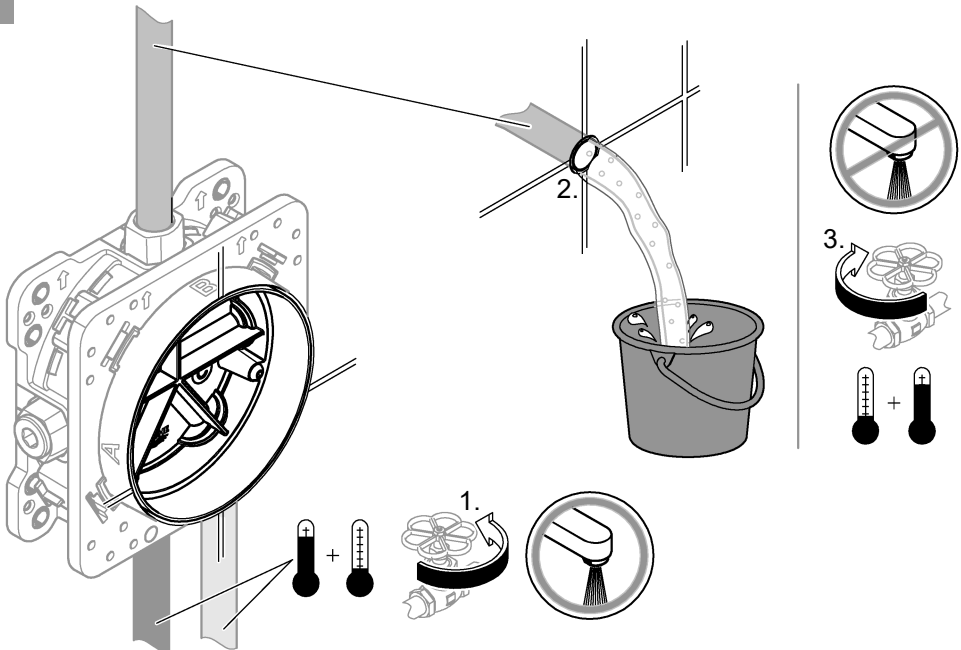



8

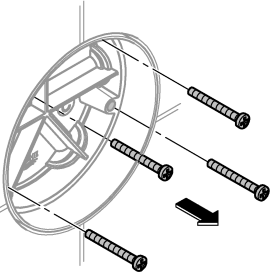

9

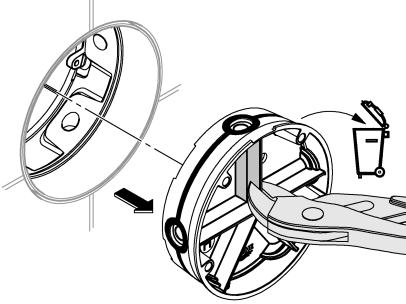

10

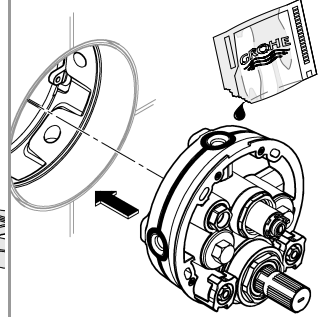

11

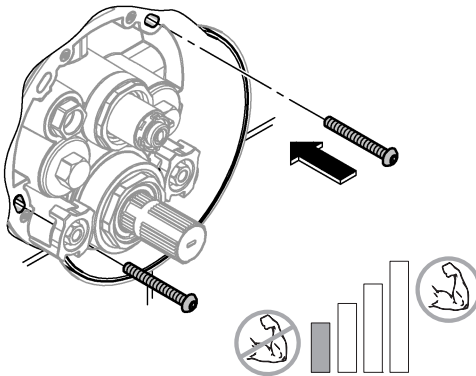

12

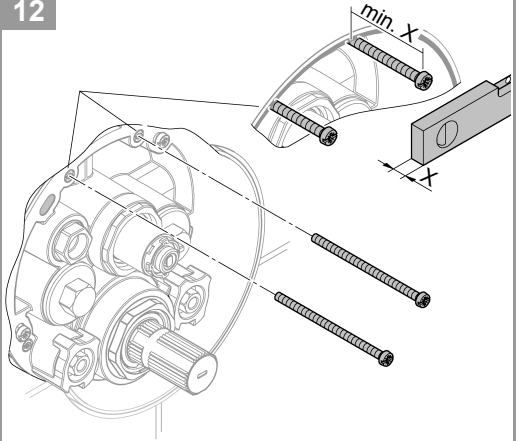

13

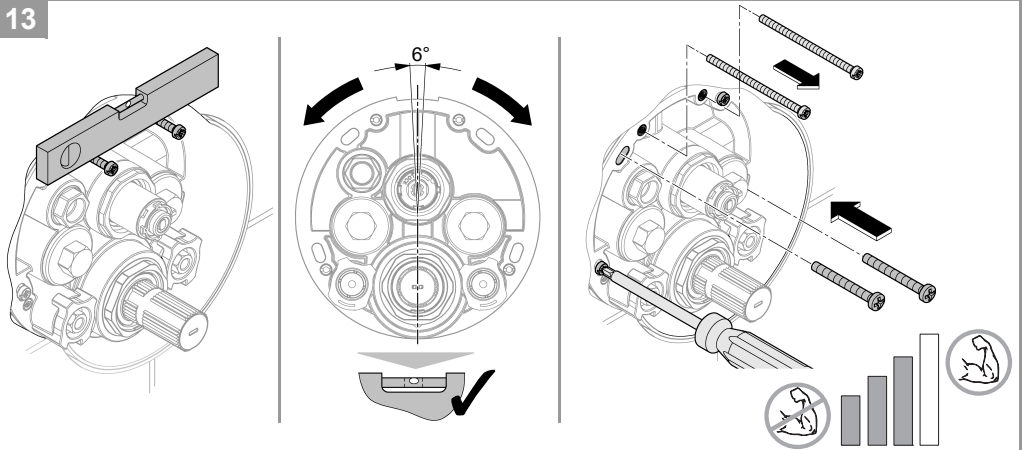



14

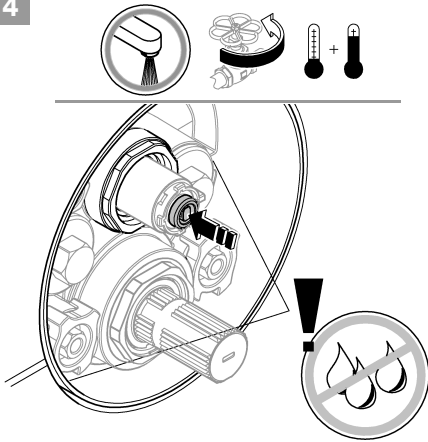

15

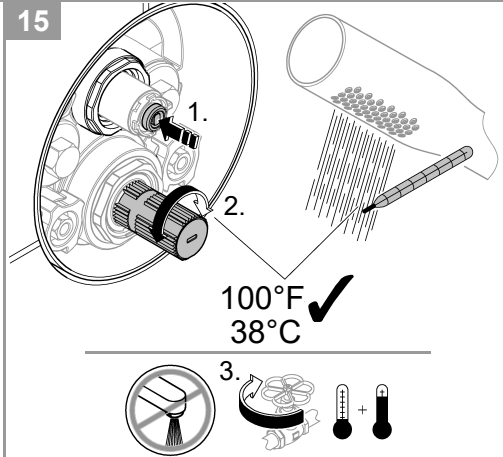

16

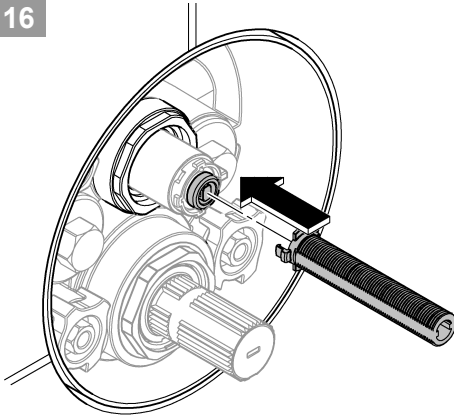

17

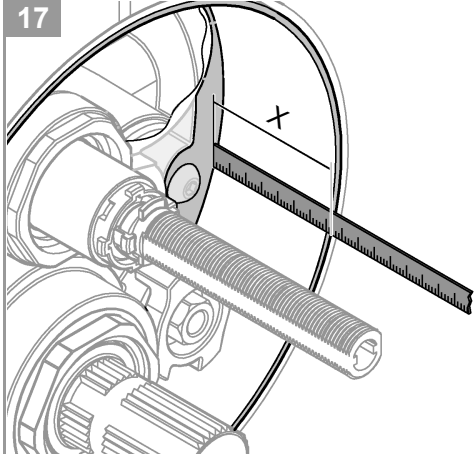

18

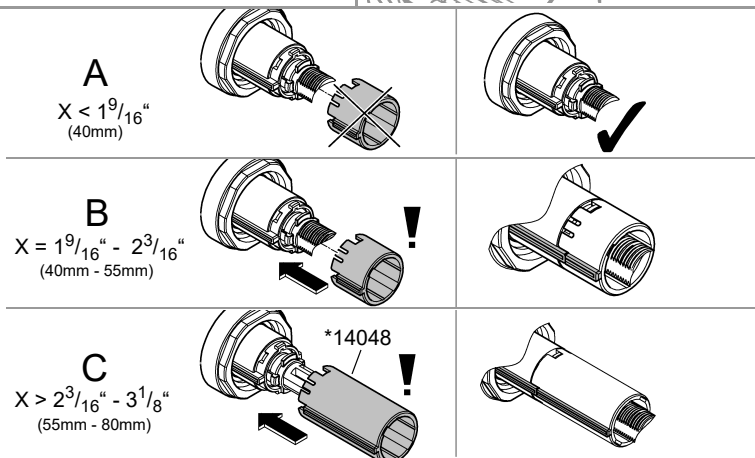



19

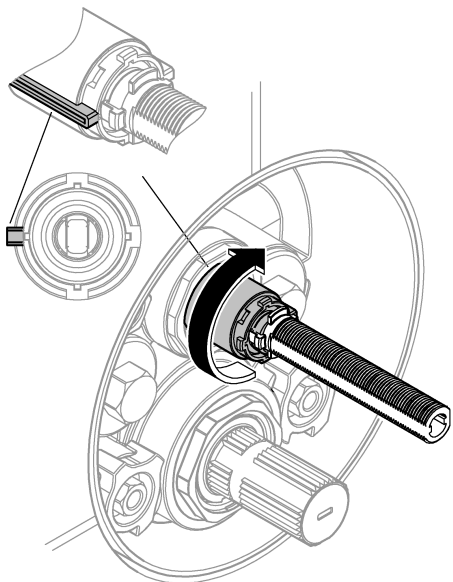

20

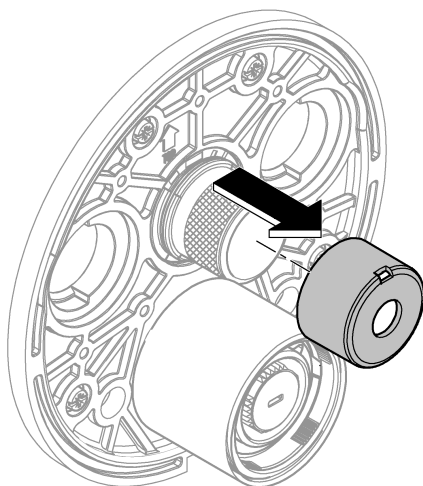

21

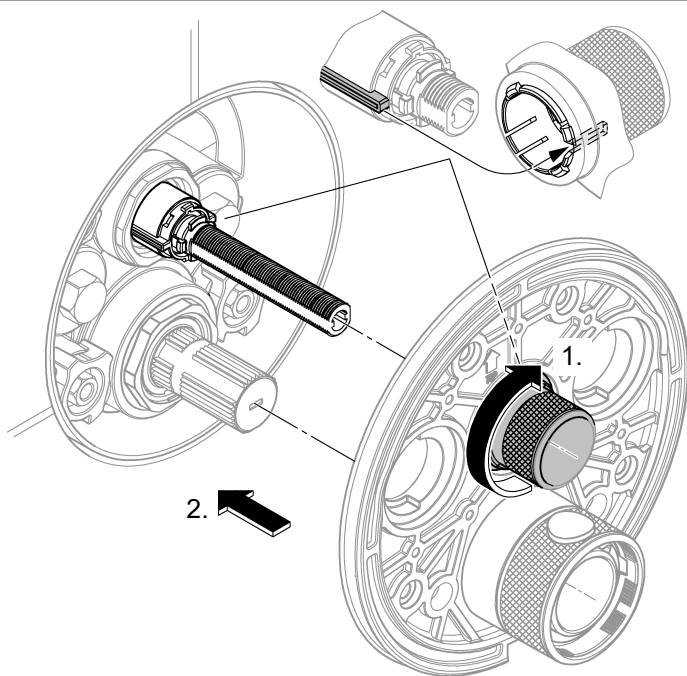



22

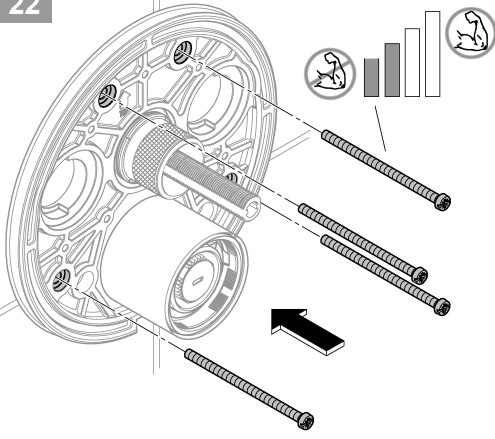

23

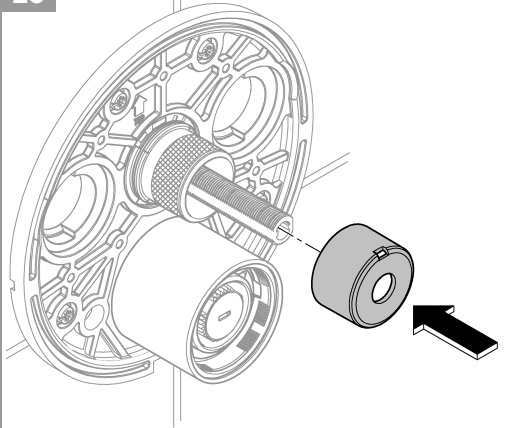

24

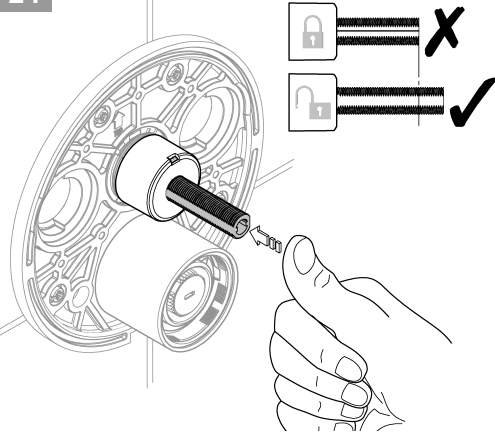

25

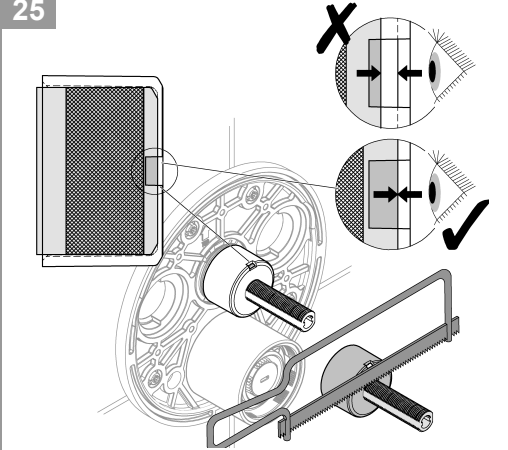

26

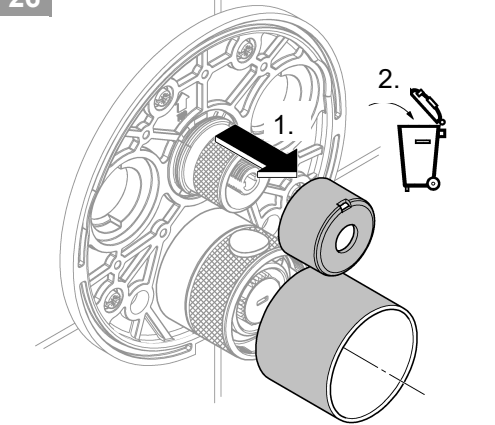

27

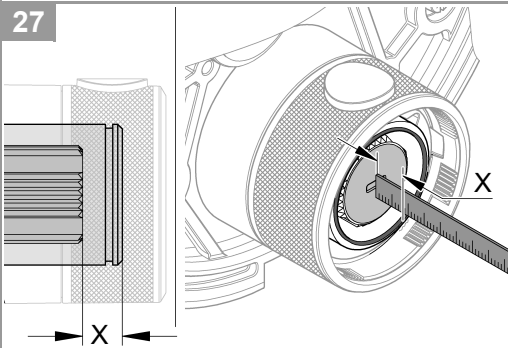

$X < 1\frac{3}{16}''$ (29,5) 28

$X > 1\frac{3}{16}''$ (29,5) *14 048



28

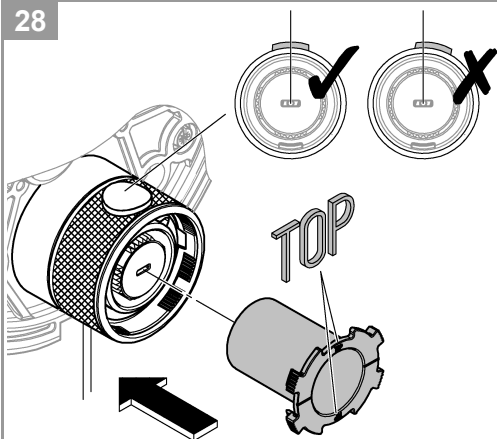

29

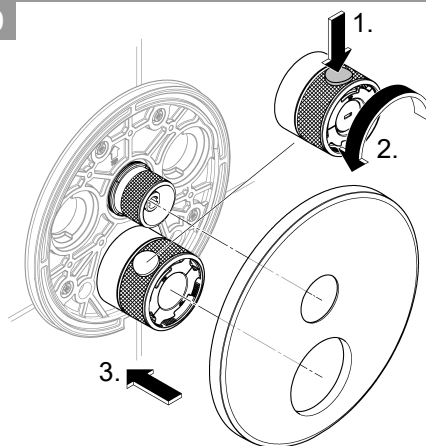

30

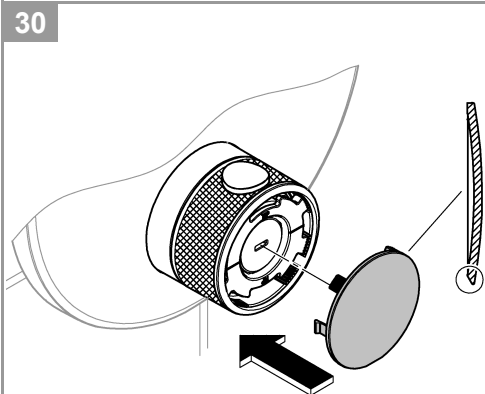

31

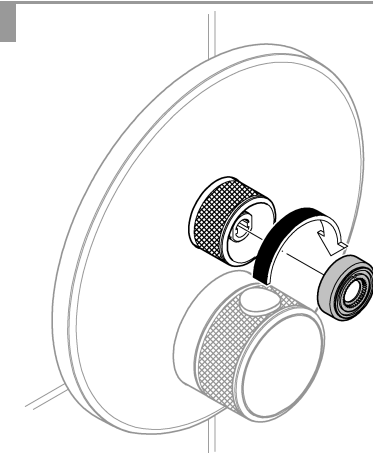

32

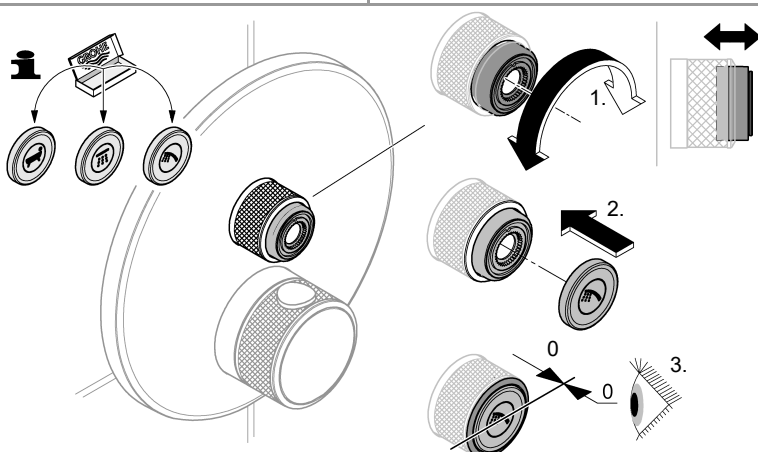



MAINTENANCE

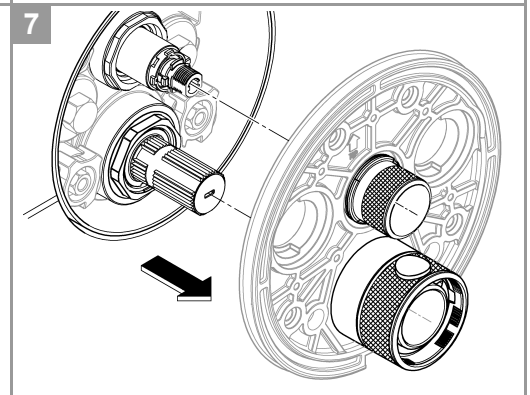
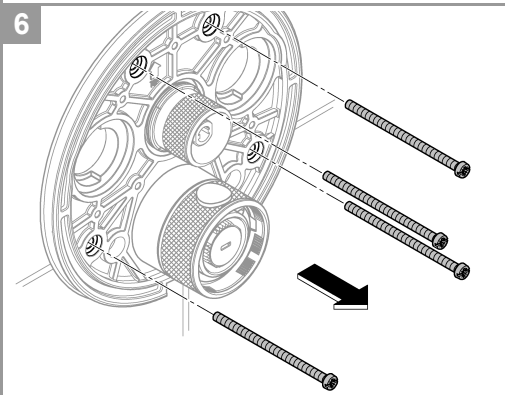
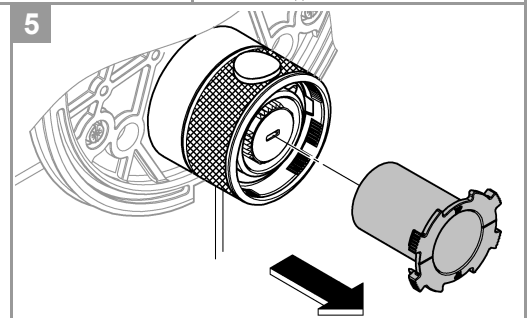
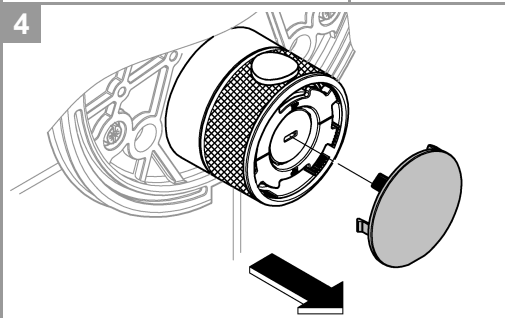
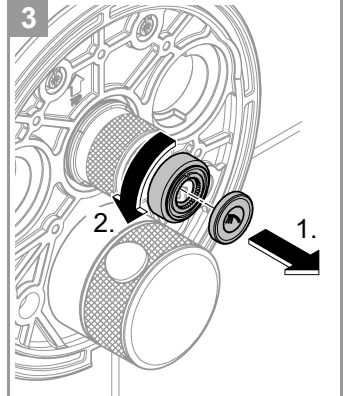
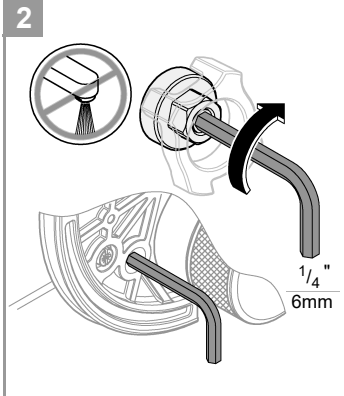
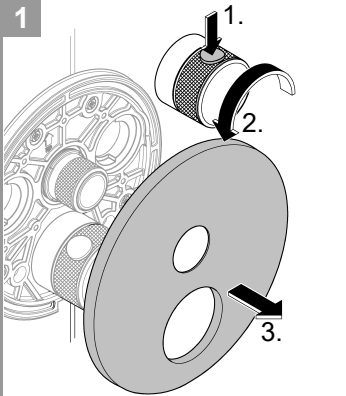
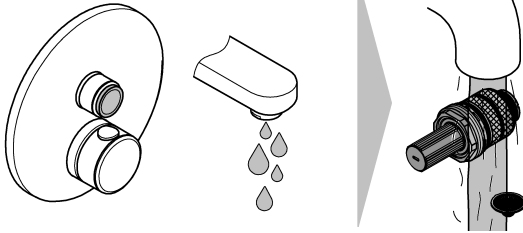



MAINTENANCE



8a

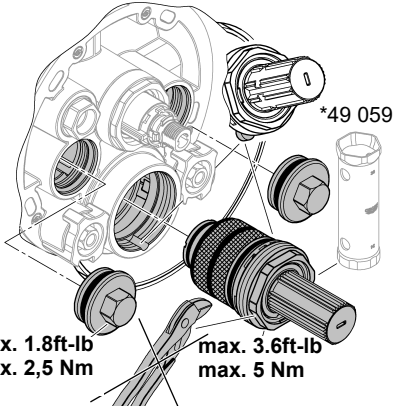

9a

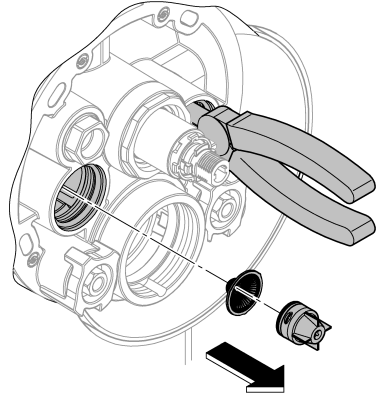

MAINTENANCE



8b

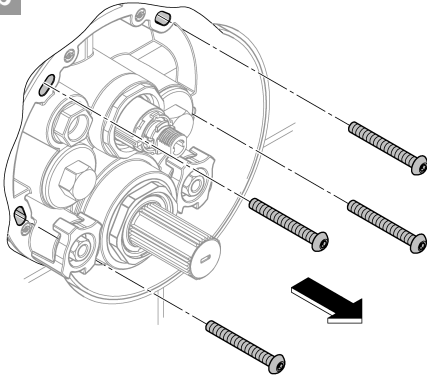

9b

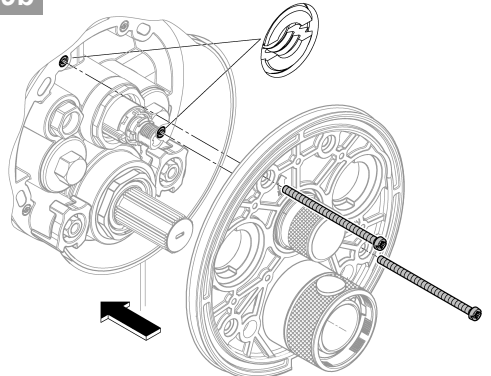

10b

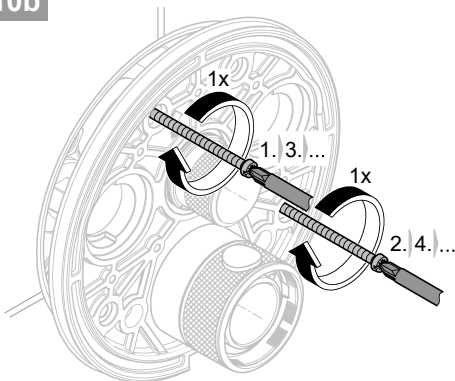

11b

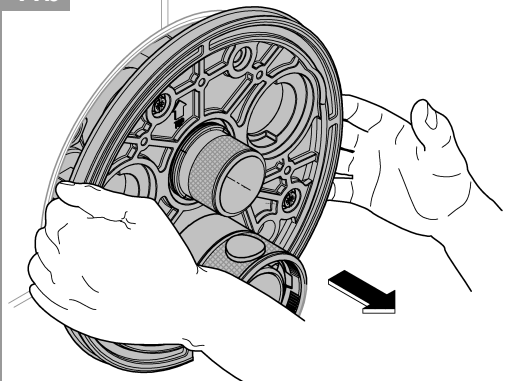

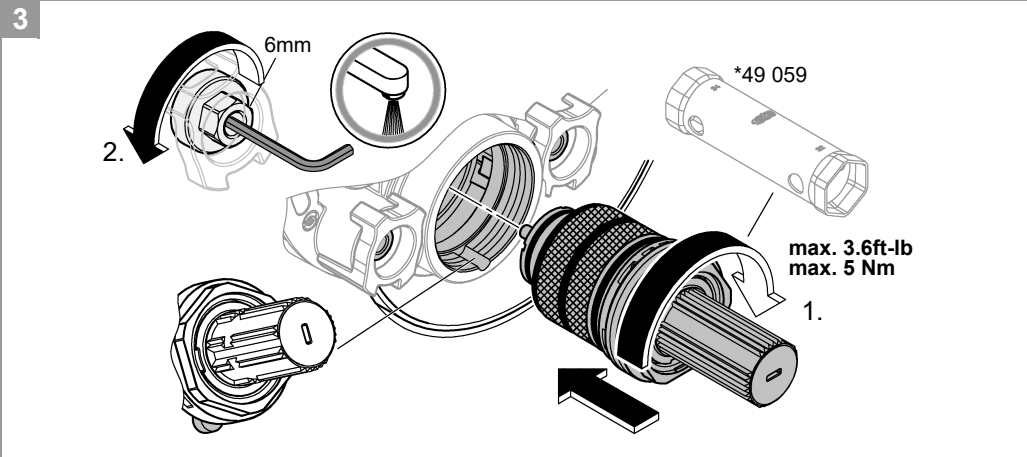
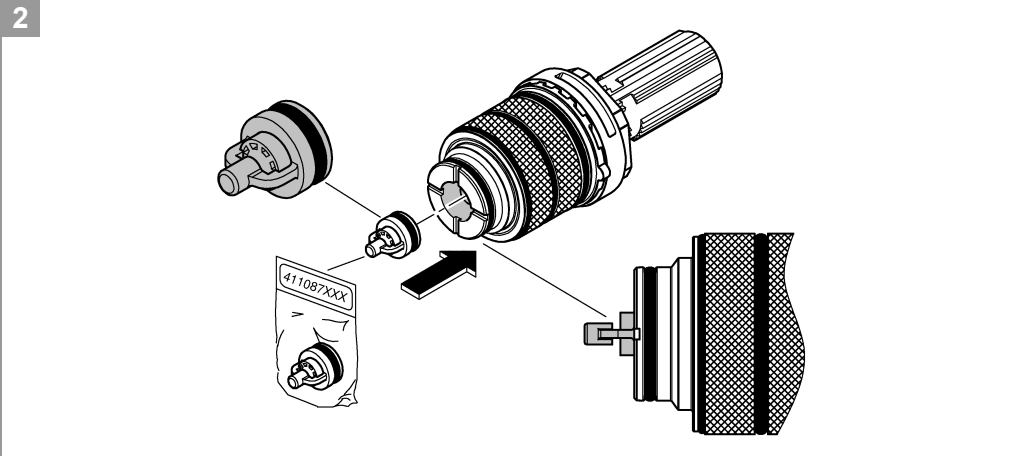
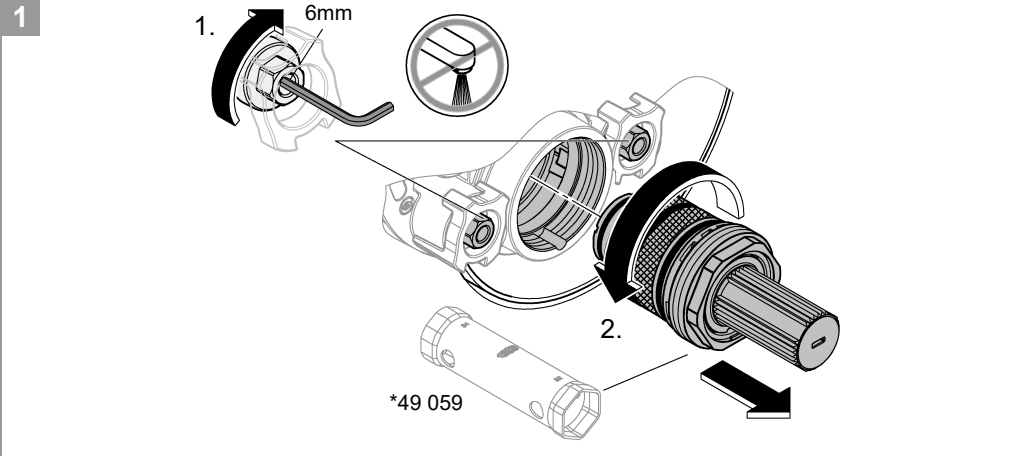

Note

Please know and follow all applicable local plumbing codes when setting the temperature on the water heater.

Only for shower application:

If your local plumbing code requires to install the limiter to reduce the total flow of water in the shower to 1.8gpm at 80psi, see page 12.

Technical Data

- Flow pressure
- Minimum flow pressure without downstream resistances 7.25 psi
- Minimum flow pressure with downstream resistances 14.5 psi
- Recommended 21.75–72.5 psi
- Temperature
- Hot water supply max. 158 °F
- Recommended for energy saving 140 °F
- Thermal disinfection possible
- Hot water temperature at supply connection min. 3.6 °F higher than mixed water temperature

Flow rates without downstream resistances, see page 2.

These should be observed when dimensioning the outlet!

The following special accessories are available:

- Extension 1" (25mm) (prod. no.: 14 048)

Thermostat compact cartridge for exchanged water channels: Reversed connections, hot on right and cold on left, replace compact cartridge (prod. no.: 49 003)

Installation

- In order to flush, remove the plugs (Y), see page 3 Fig. [4].
- Open cold and hot water supply and check connections for watertightness!
- Alignment of functional unit by 6° possible.
- Measure valves, see page 6 Fig. [17]. For a dimension larger than $1\frac{9}{16}$ " (40mm), the enclosed extension must be used.

Adjusting to 100 °F

- Before the mixer is put into service if the mixed water temperature measured at the point of discharge varies from the desired temperature set on the thermostat, see page 6 Fig. [15].
- Every time following maintenance on the thermostatic compact cartridge.

Temperature limitation

The safety stop limits the temperature range to 100 °F. If a higher temperature is required, the 100 °F stop can be overridden by pressing the button.

In accordance with local plumbing codes, this thermostat is limited to a maximum temperature of 109 °F.

Danger of frost damage

When the domestic water system is drained, the thermostats must be drained separately since non-return valves are installed in the hot and cold water connections.

Remarque

Vous devez connaître et respecter tous les codes de plomberie locaux applicables pour le réglage de la température du chauffe-eau.

Seulement pour l'application de douche:

Si votre code de plomberie exige, installez le limiteur de débit pour réduire le débit total de l'eau dans la douche à 6,8 l/min à 5,5 bar, voir page 12.

Caractéristiques techniques

- Pression dynamique
- Pression dynamique minimale sans résistances en aval 0,5 bar
- Pression dynamique minimale avec résistances en aval 1 bar
- Recommandée 1,5 à 5 bars
- Température
- Entrée d'eau chaude max. 70 °C
- Recommandée pour économie d'énergie 60 °C
- Désinfection thermique possible
- Température de l'eau chaude au raccord d'alimentation au moins 2 °C supérieure à la température de l'eau mitigée

Débits sans résistances en aval, voir page 2. **Respecter les données indiquées lors du dimensionnement de l'évacuation !**

Les accessoires spéciaux suivants sont disponibles :

- Extension de 25mm (réf. : 14 048)

Cartouche compacte de thermostatique pour raccordements inversés : Raccordements inversés (chaud à droite, froid à gauche), remplacer la cartouche compacte (réf. : 49 003)

Installation

- Pour le rinçage, démonter les clapets (Y), voir page 2, fig. [4].
- Ouvrir les arrivées d'eau froide et d'eau chaude et vérifier l'étanchéité des raccordements.
- Possibilité d'orienter l'unité de commande de 6°.
- Mesurer les vannes, voir page 6, fig. [17]. Pour des dimensions supérieures à 40mm, utiliser l'extension fournie.

Réglage sur 38 °C

- Préalablement à la mise en service : si la température de l'eau mitigée mesurée au point de puisage est différente de la température souhaitée réglée au niveau de la poignée graduée du thermostatique, voir page 6, fig. [15].
- Après chaque opération de maintenance sur la cartouche compacte du thermostatique.

Limitation de la température

La température est limitée à 38 °C par la butée de sécurité. Il est possible d'obtenir une température plus élevée (supérieure à 38 °C) en appuyant sur le bouton.

Conformément aux directives locales d'installation, ce thermostatique est limité à une température max. de 43 °C.

Attention en cas de risque de gel

Lors du vidage de l'installation sanitaire, il convient de vider séparément les thermostatiques dont les raccordements d'eau froide et d'eau chaude sont équipés de clapets anti-retour.

Nota

Debe conocer y cumplir todos los códigos locales aplicables para ajustar la temperatura del calentador de agua.

Solo para la aplicación de ducha:

Si el código de instalación local requiere, instale el limitador de caudal para reducir el caudal total de agua en la ducha a 1.8gpm a 80psi, véase la página 12.

Datos técnicos

- Presión de trabajo
- Presión mínima de trabajo sin resistencias postacopladas 7.25 psi
- Presión mínima de trabajo con resistencias postacoplada 14.5 psi
- Recomendado 21.75-72.5 psi
- Temperatura
- Entrada de agua caliente máx. 158 °F
- Recomendado para ahorrar energía 140 °F
- Desinfección térmica posible
- La temperatura del agua caliente en la acometida de mín. 3.6 °F es superior a la temperatura del agua mezclada

Caudales sin resistencias postacopladas, véase la página 2.

Tenga en cuenta las dimensiones del desagüe.

Los siguientes accesorios especiales están disponibles:

- Prolongación de 1" (25mm) (n.º de pedido: 14 048)

Cartuchos compactos de termostato para las entradas de agua intercambiadas: Conexión invertida, sustituir los cartuchos compactos, los calientes en el lado derecho y los fríos en el izquierdo (n.º de pedido: 49 003)

Instalación

- Para lavar, desmonte el tapón (Y), véase la página 3 fig. [4].
- Abrir las llaves de paso del agua fría y del agua caliente y comprobar la estanqueidad de las conexiones.
- Es posible alinear la unidad de funcionamiento 6°.
- Medir las válvulas, véase la página 6 fig. [17]. Para una medida más grande de 1⁹/₁₆" (40mm), se debe utilizar la prolongación suministrada.

Ajustar a 100 °F

- Antes de la puesta en servicio, si la temperatura del agua mezclada medida en el punto de consumo difiere de la temperatura teórica ajustada en el termostato, véase la página 6 fig. [15].
- Después de cada operación de mantenimiento en el cartucho compacto del termostato.

Limitación de la temperatura

La gama de temperaturas está limitada a 100 °F mediante el cierre de seguridad. Si desea seleccionar una temperatura más alta, se puede exceder el límite de 100 °F presionando la tecla.

En las normas de instalación locales el termostato tiene una temperatura máxima establecida de 109 °F.

Atención en caso de peligro de helada

Al vaciar la instalación de la casa, los termostatos deberán vaciarse por separado, ya que hay válvulas antirretorno en las conexiones del agua fría y caliente.

