

Customer support flowchart showing a person with a question mark, a person on a phone, a person at a computer, a QR code, a product box, a person with a clipboard, and a person with a pencil.

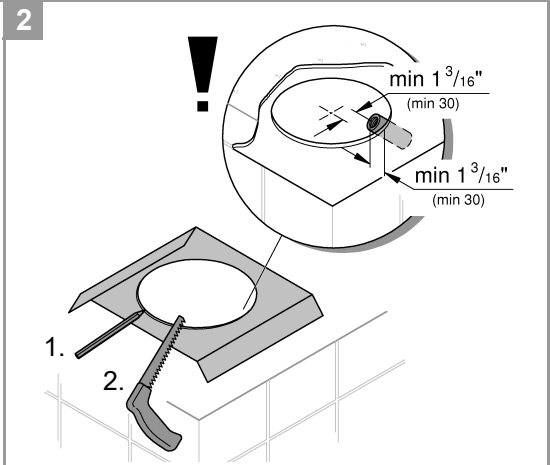

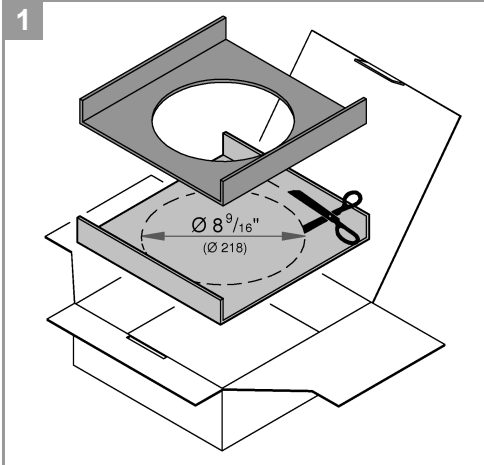

3

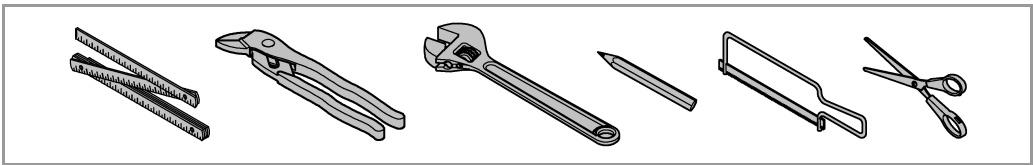
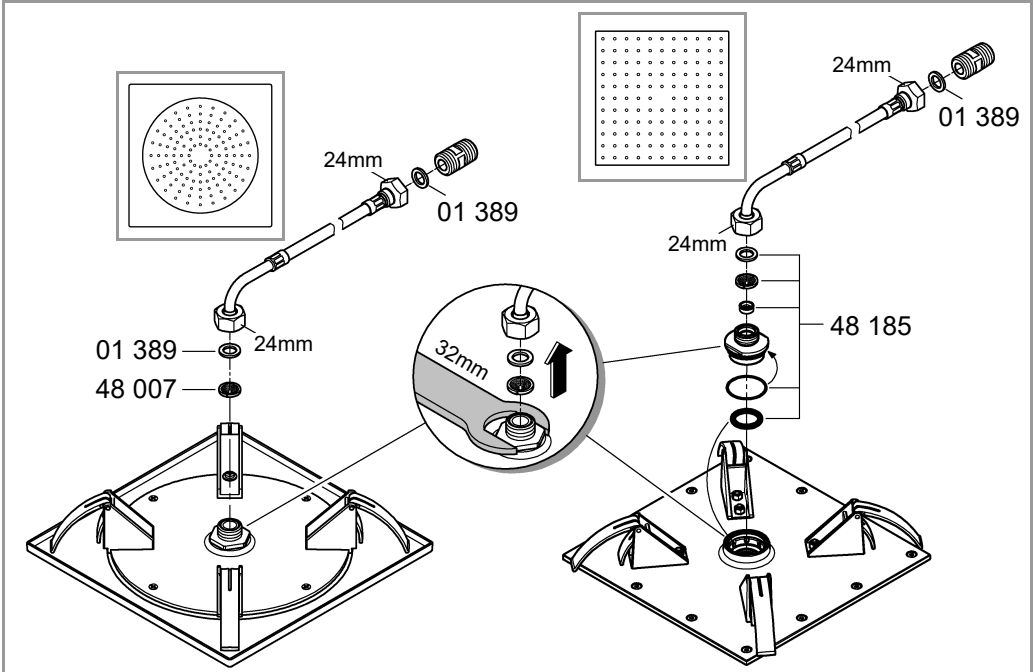
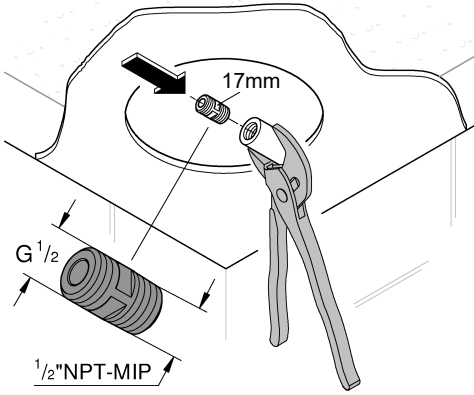

4

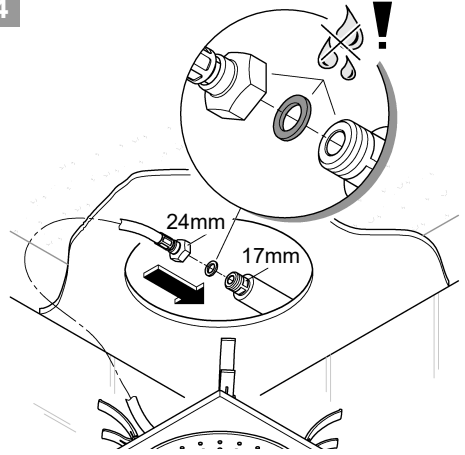

5

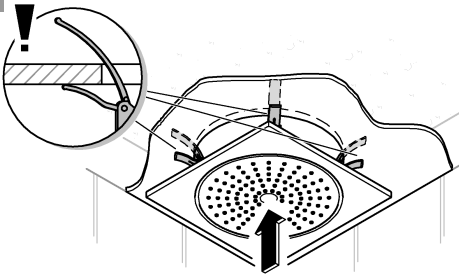

6

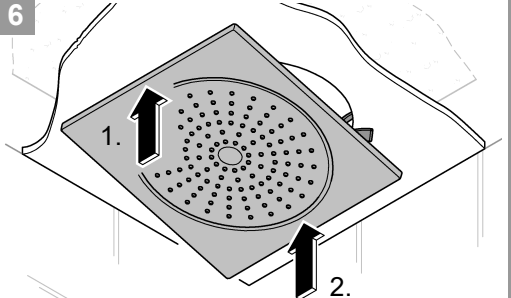

MAINTENANCE

