

26 613

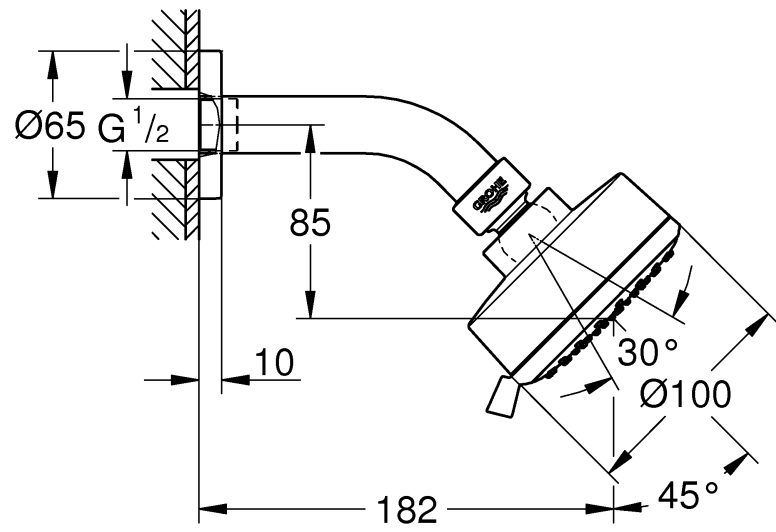

26 615

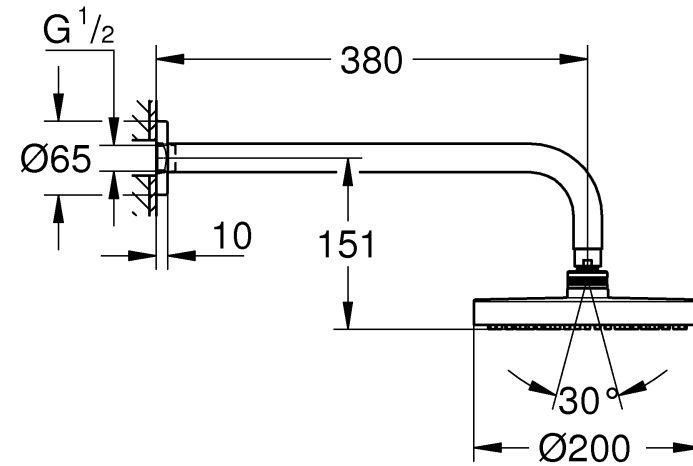

26 626

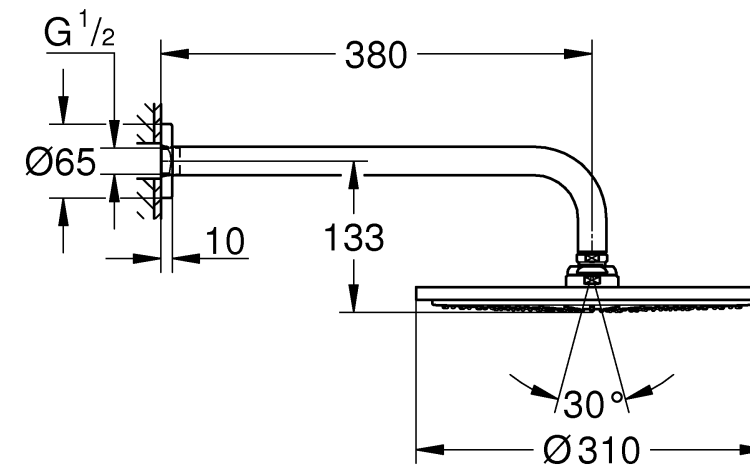

26 629

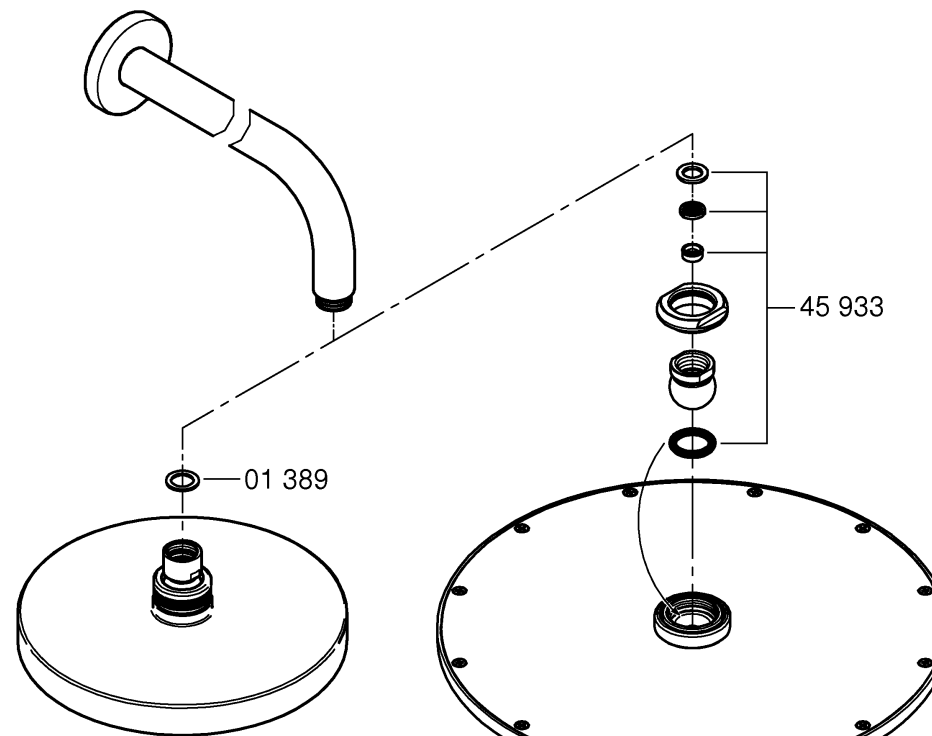
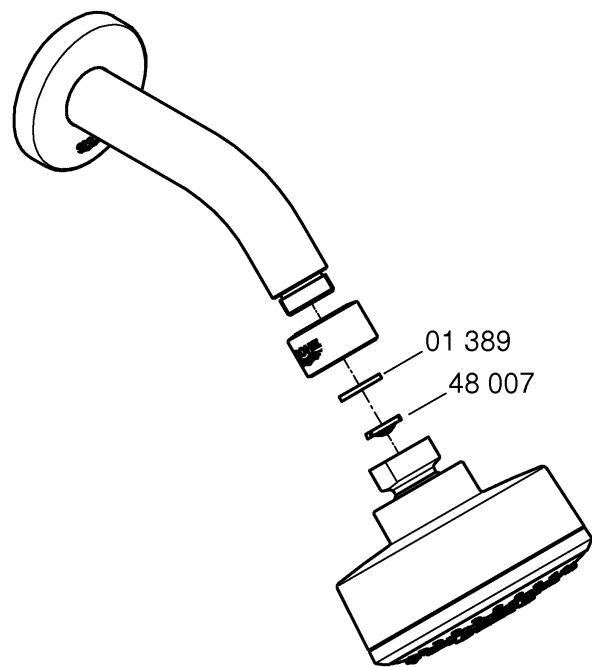
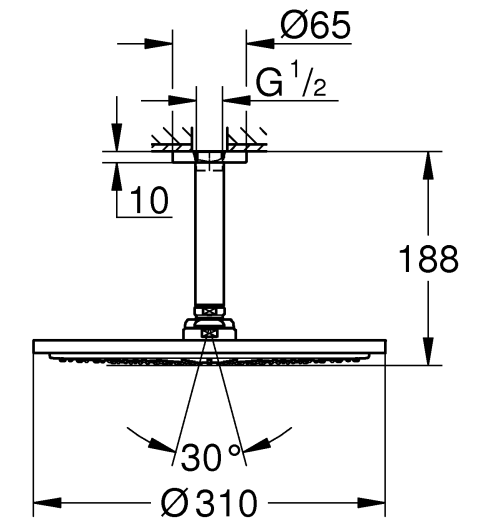

26 615

26 626

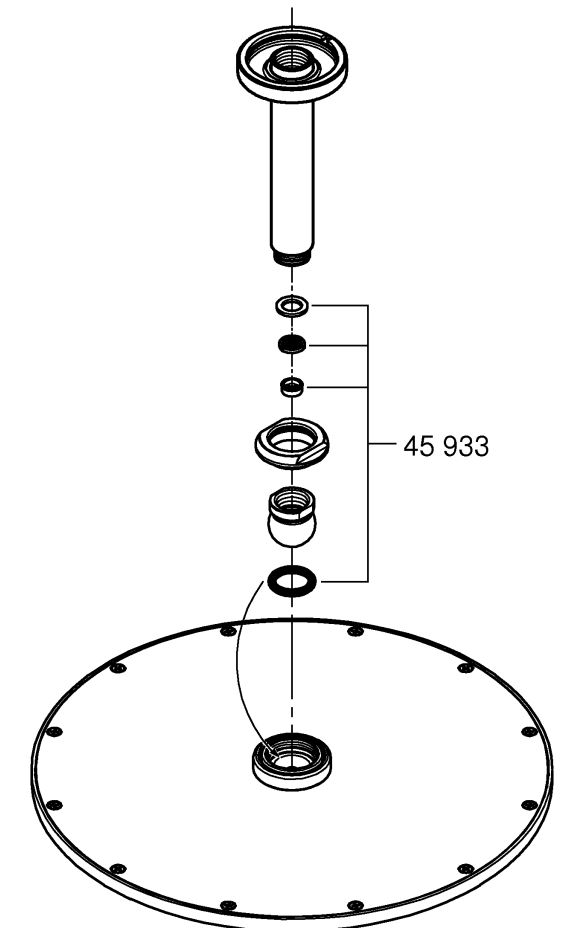

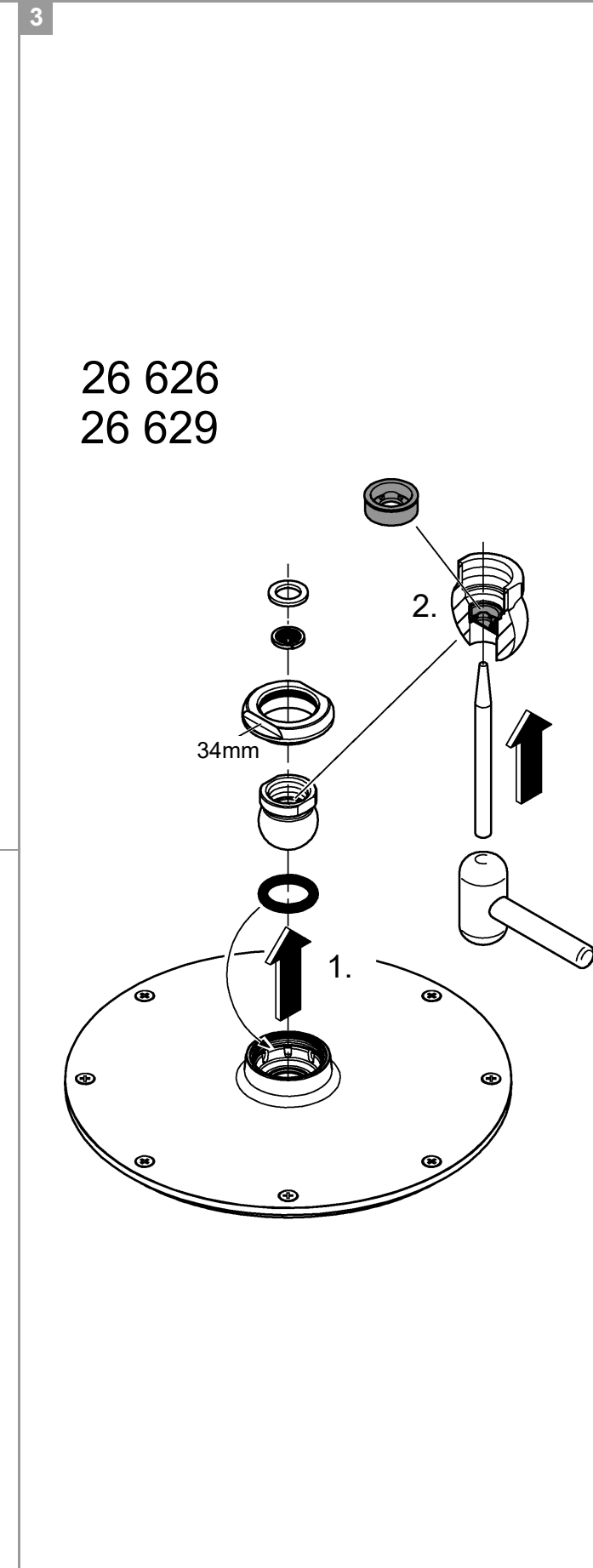
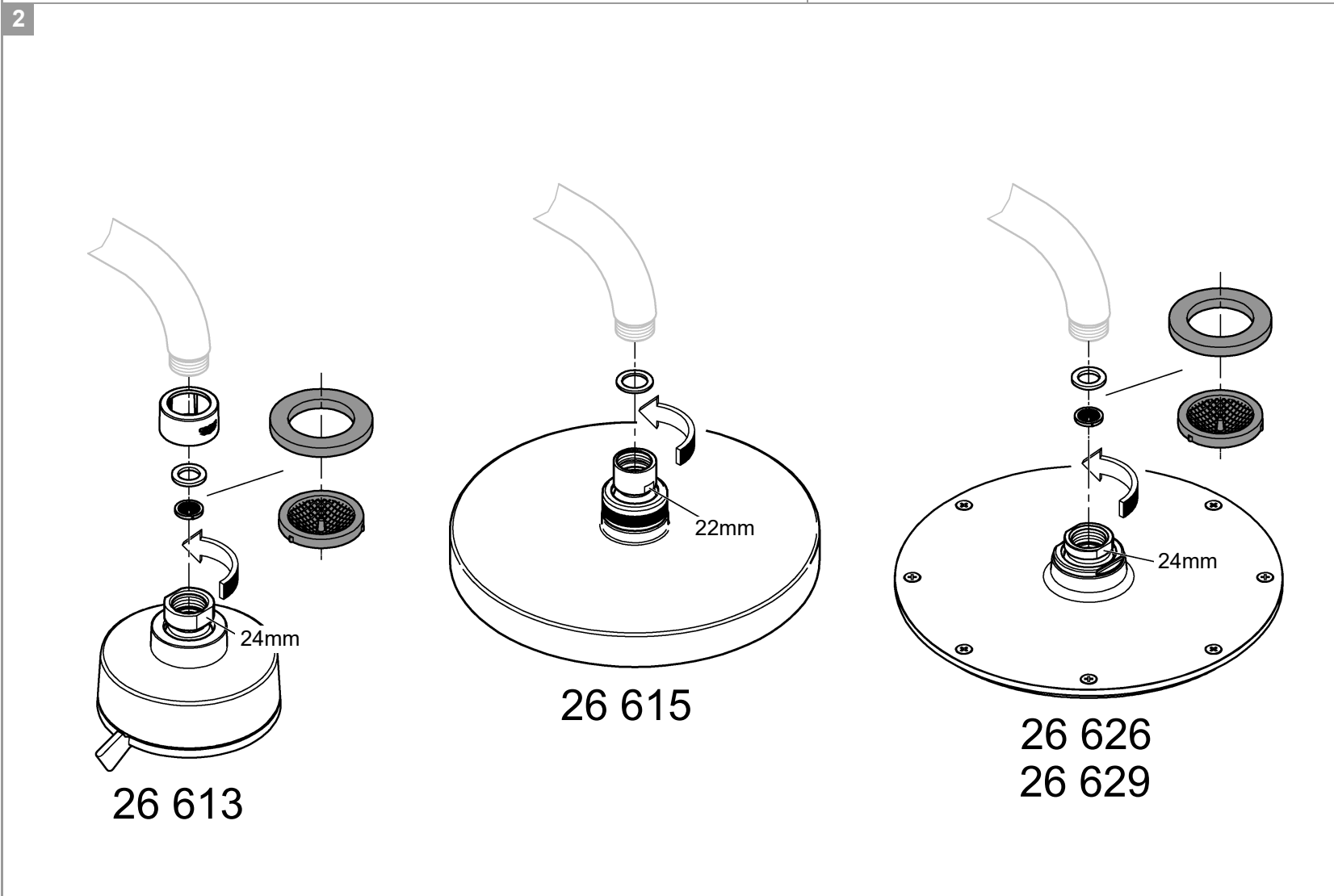
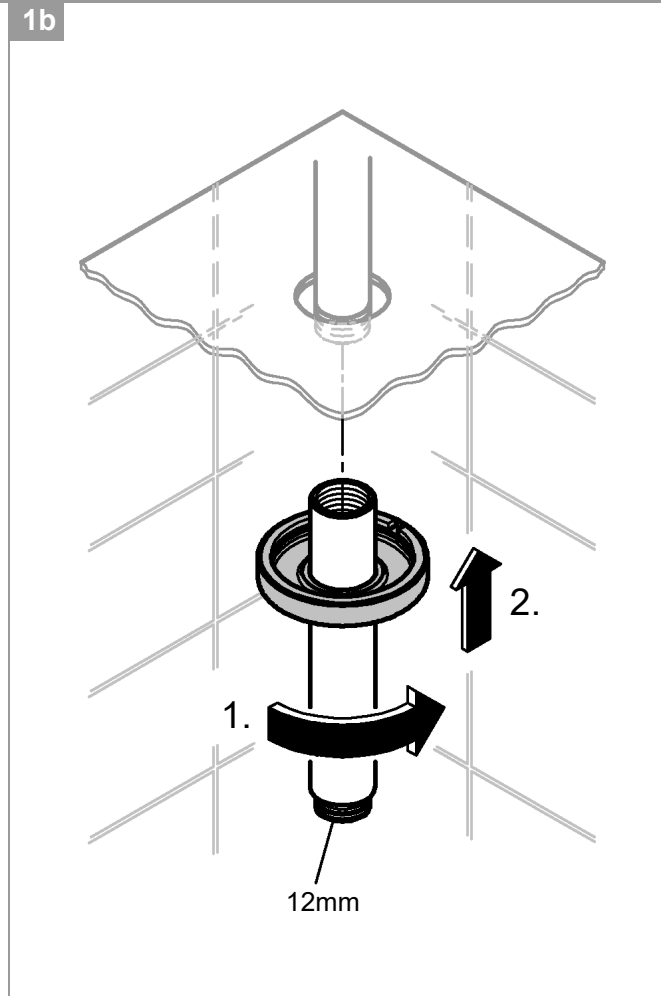
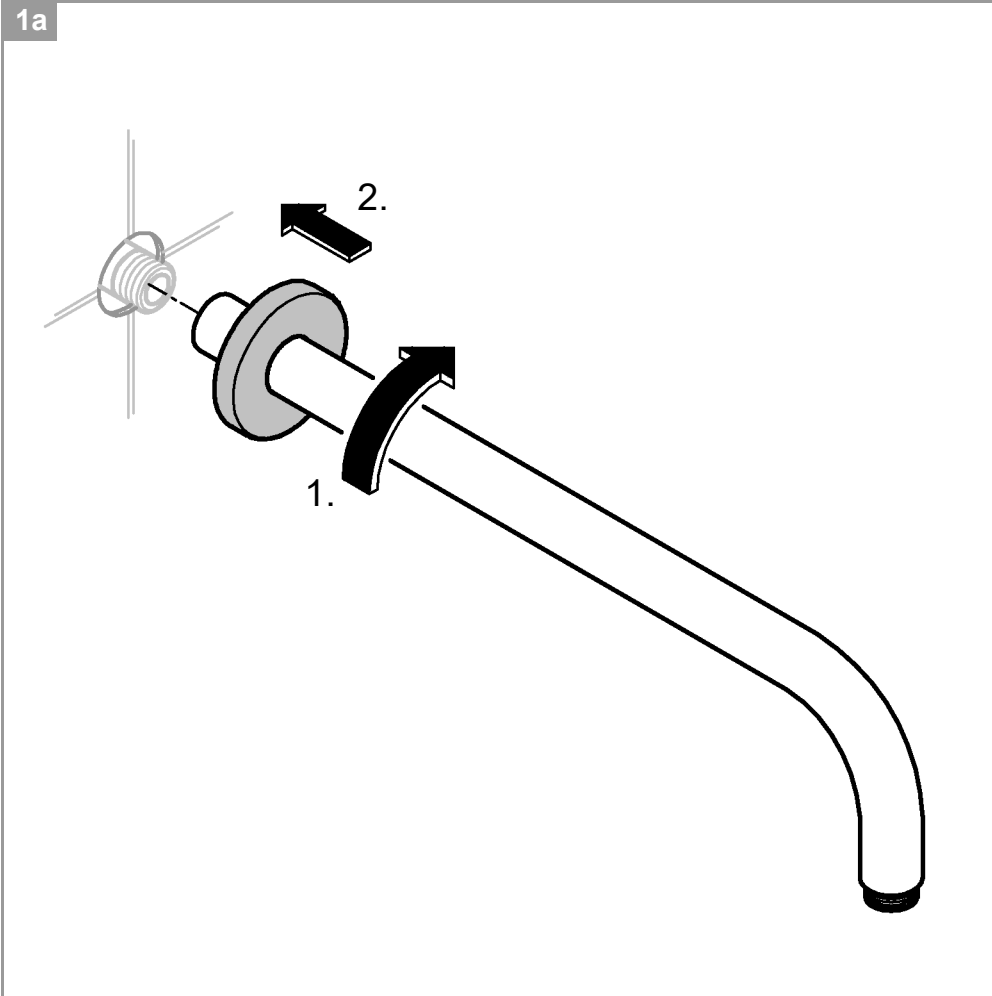

Application

- for shower
- Can be used in conjunction with:
 - Pressurised storage heaters
 - Thermally controlled instantaneous heaters
 - Hydraulically controlled instantaneous heaters
- Operation with unpressurised storage heaters (open water heaters) is not possible.

Specifications

- Flow pressure min. 50 kPa - recommended 100 - 500 kPa
- Operating pressure max. 500 kPa

If static pressure is greater than 500 kPa, fit pressure reducer.
Avoid major pressure differences between hot and cold water supply.

- 26 613:
- Flow rate at 300 kPa flow pressure approx. 7.5 L/min
- 26 615, 26 626, 26 629:
- Flow rate at 300 kPa flow pressure approx. 9 L/min

Installation

Flush piping system prior and after installation of fitting thoroughly (Consider EN 806)!

This product must be installed in conformance with local codes e.g. AS/NZS 3500 series of standard!

Installation and connection, see Figs. [1] and [2].

When installing e.g. on plasterboard walls (not solid walls) it must be assured that an appropriate reinforcement is in place to ensure sufficient strength.

Open cold and hot water supply and check connections for leakage!

Maintenance, see Fig. [3].

AUS
Tel.: 1800 080 055
Email: customer.care@reece.com.au



NZ
Tel.: +64 09 573 0490
Email: sales@robertson.co.nz