

31 117

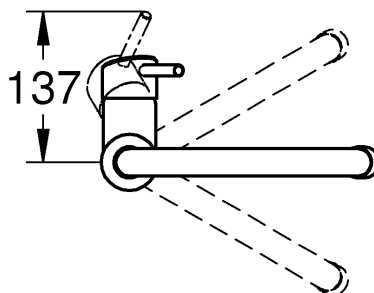

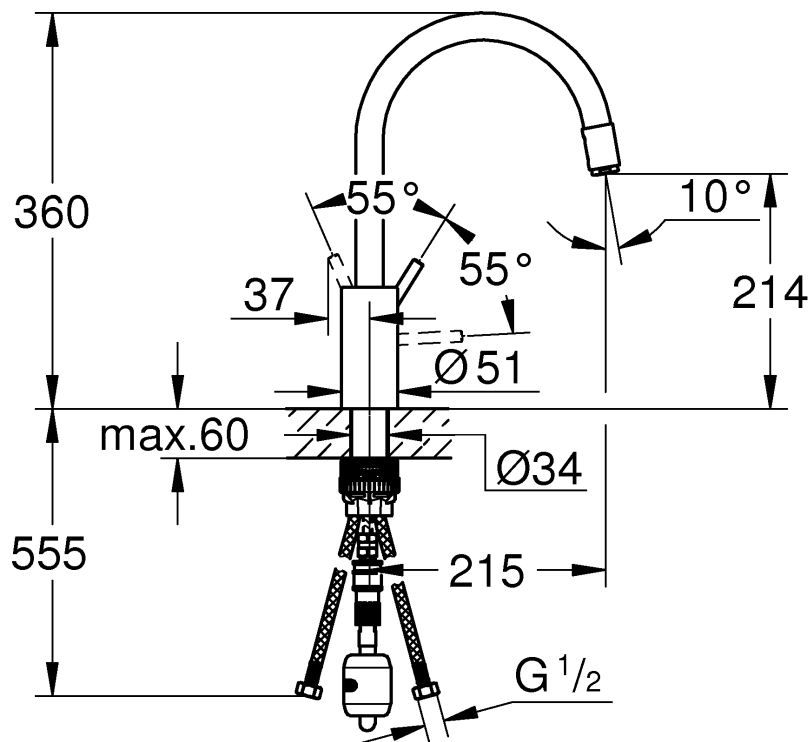

32mm

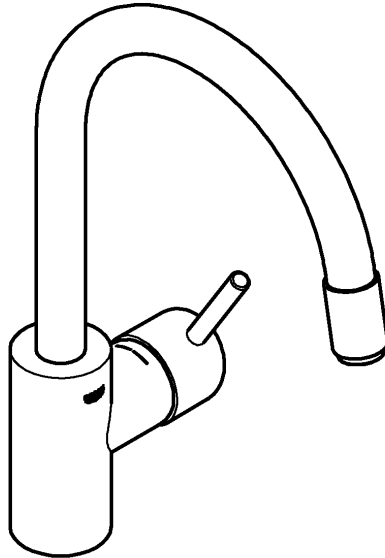
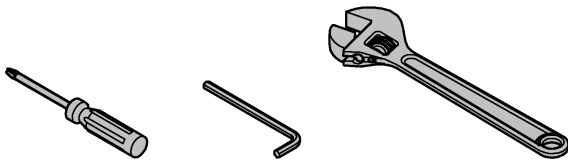

*19 332

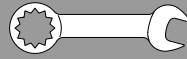

1

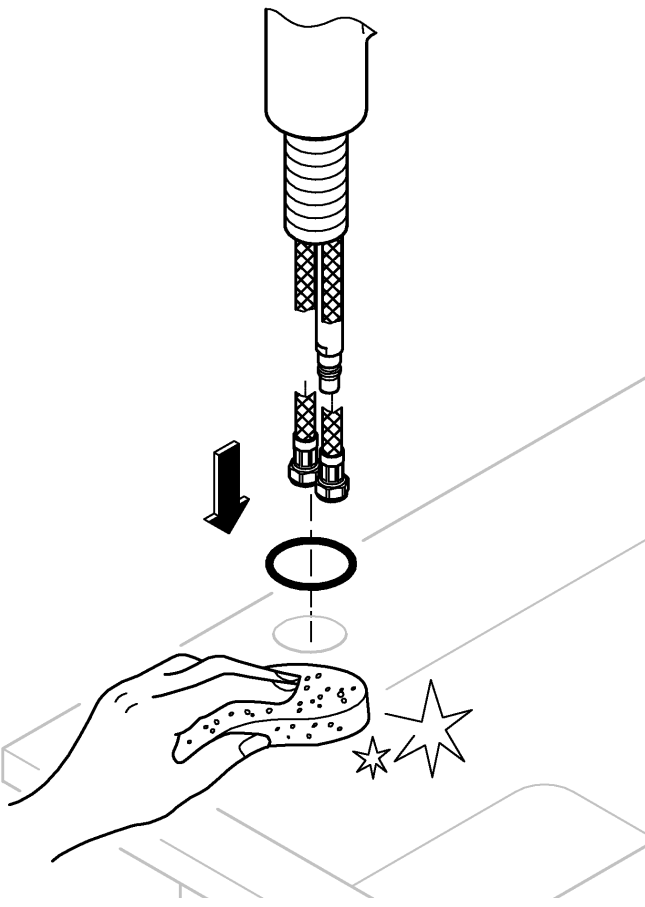

2

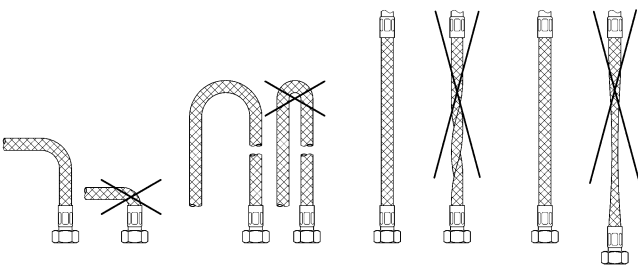
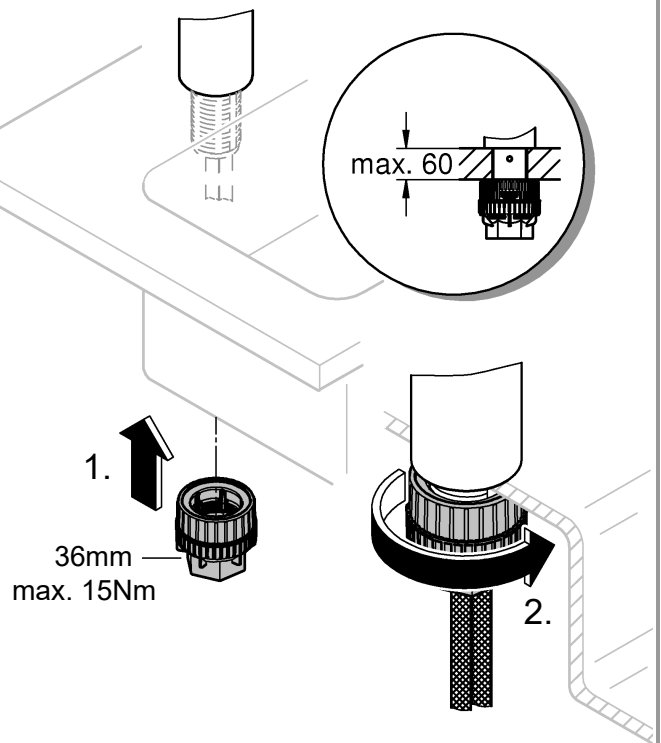

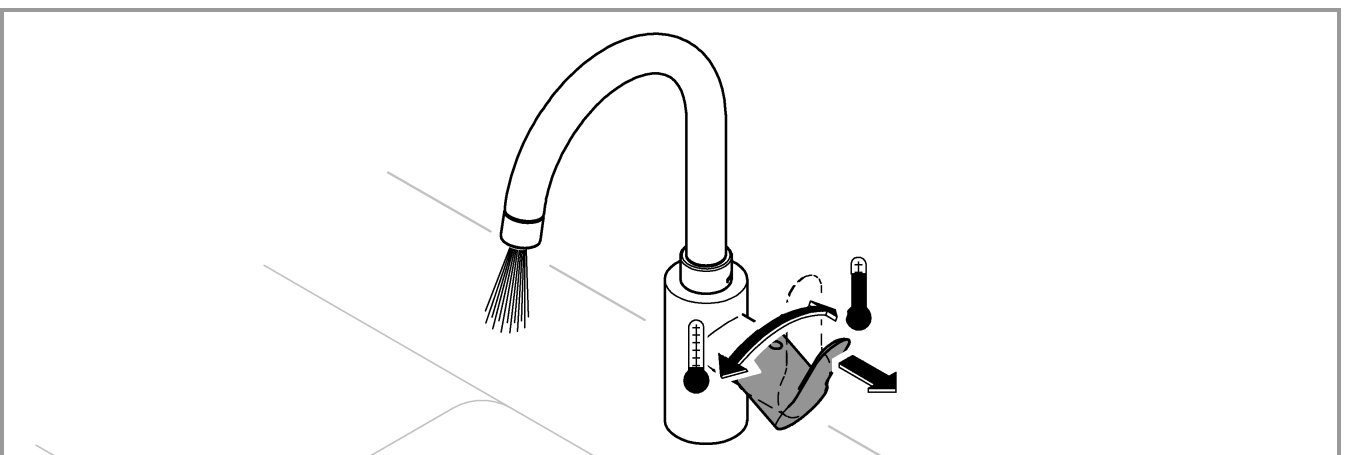
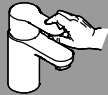
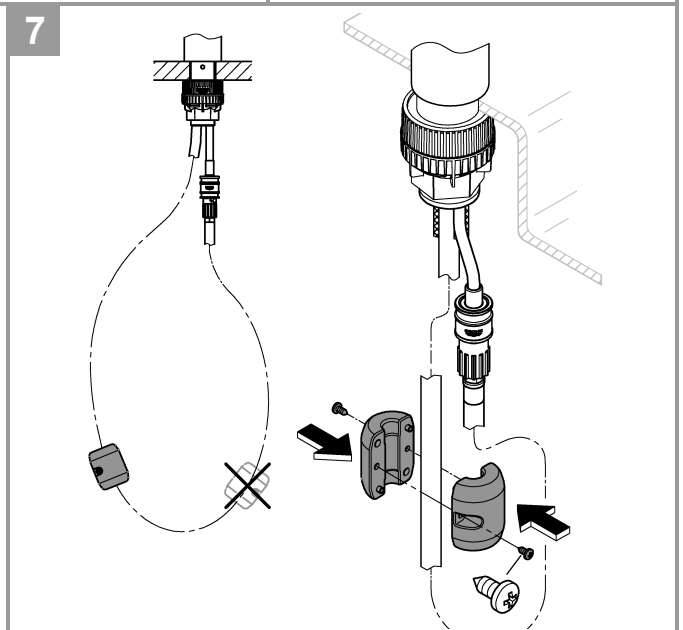
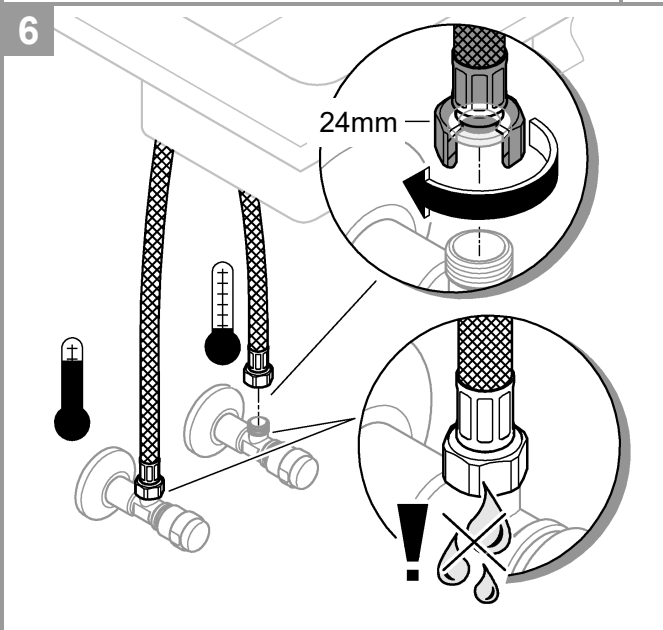
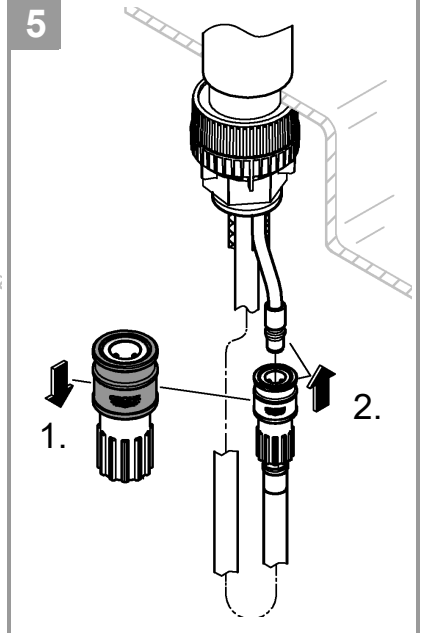
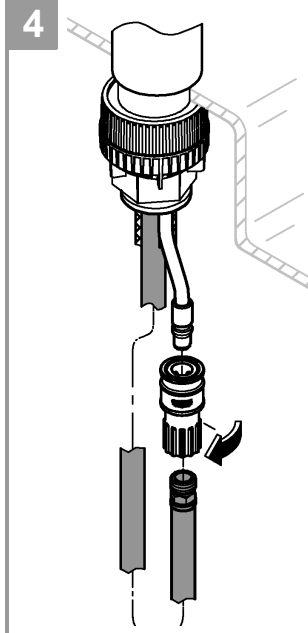
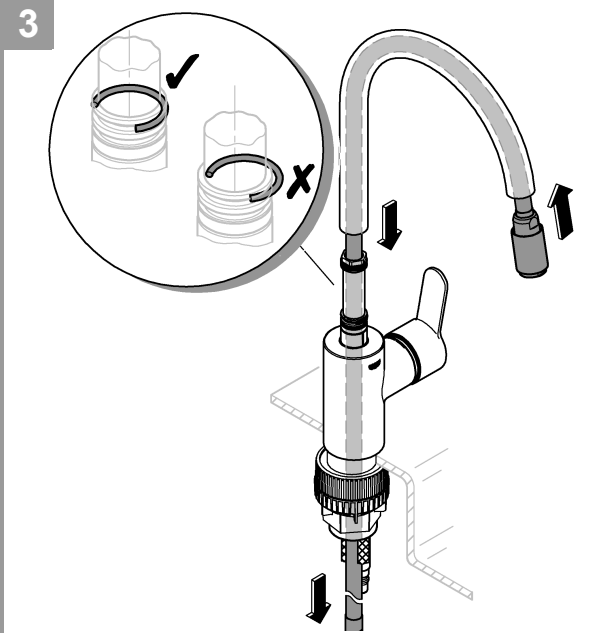

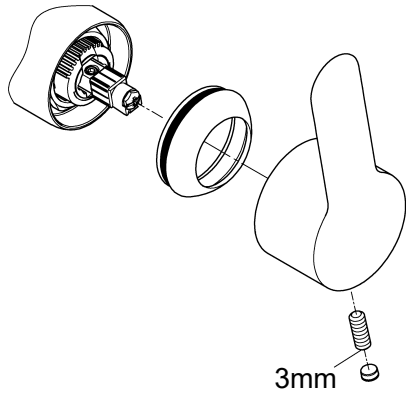

3mm

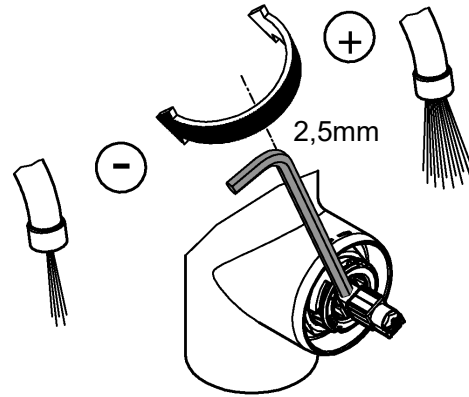

2,5mm

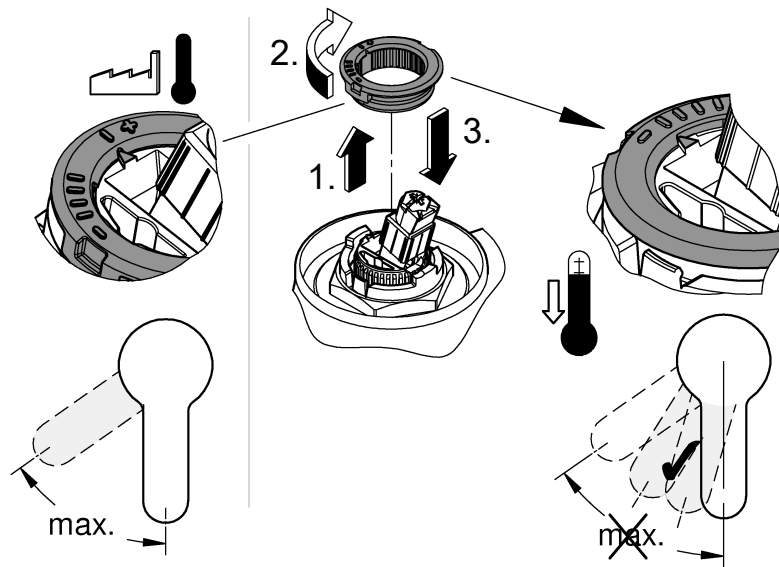

MAINTENANCE 

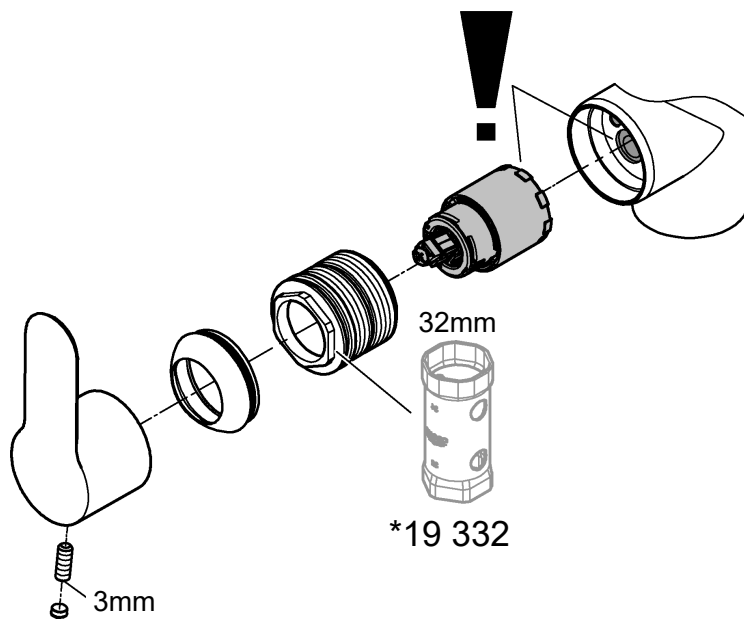
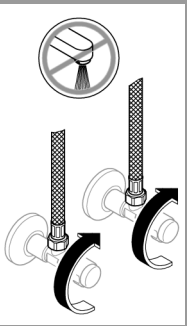



32mm

*19 332

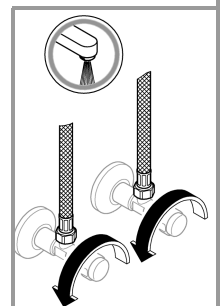
3mm

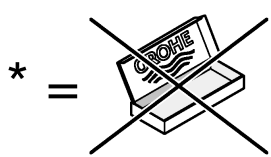
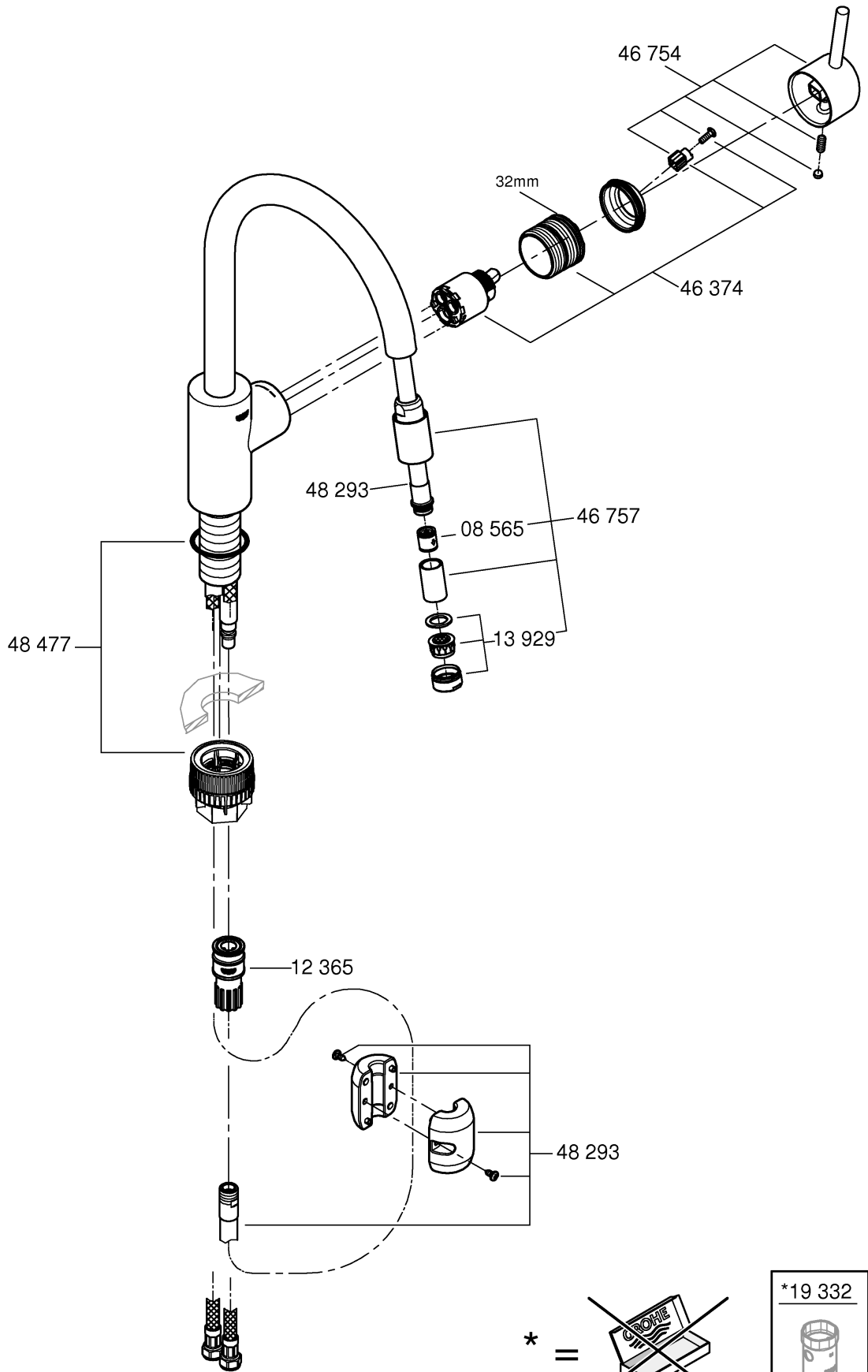



*19 332	32mm
	

Application

- for kitchen

Can be used in conjunction with:

- Pressurised storage heaters
- Thermally controlled instantaneous heaters
- Hydraulically controlled instantaneous heaters

Operation with unpressurised storage heaters (open water heaters) is **not** possible.

Specifications

- Flow pressure
min. 50 kPa - recommended 100 - 500 kPa
- Operating pressure max. 1000 kPa
- Test pressure 1600 kPa

If static pressure is greater than 500 kPa, fit pressure reducer.

Avoid major pressure differences between hot and cold water supply.

- Flow rate at 300 kPa flow pressure approx. 6 L/min
- Temperature
Hot water inlet: (maximum) 70 °C
Recommended: (energy saving) 60 °C

Thermal disinfection possible

- Water connection
cold - right
hot - left

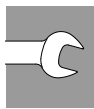

Installation

Flush piping system prior and after installation of fitting thoroughly (Consider EN 806)!

This product must be installed in conformance with local codes e.g. AS/NZS 3500 series of standard!

Installation and connection, see Fig. [1] - [7].

Refer to the dimensional drawing.

The cold-water supply must be connected on the right and the hot-water supply on the left.

Open cold and hot-water supply and check connections for watertightness!



Check fitting for correct operation.

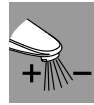

Flow rate limiter

This mixer is fitted with a flow rate limiter, permitting an infinitely individual variable reduction in the flow rate.

The highest possible flow rate is set by the factory before despatch.

The use of flow rate limiters in combination with hydraulic instantaneous water heaters is not recommended.



Maintenance

Inspect and clean all parts, replace as necessary and grease with special grease.

Shut off cold and hot water supply!

Replacing the cartridge.

Assemble in reverse order.

Observe the correct installation position!

Make sure that the cartridge seals engage in the grooves on the housing. Screw in and tighten screwing.



Replacement parts (* = special accessories).

Care

For directions on the care of this fitting, refer to the accompanying Care Instructions.

AUS

Tel.: 1800 080 055

Email: customer.care@reece.com.au



NZ

Tel.: +64 09 573 0490

Email: sales@robertson.co.nz