

LINEARE

DESIGN + ENGINEERING  
GROHE GERMANY

99.1296.031/ÄM 243799/10.19

[www.grohe.com](http://www.grohe.com)

*Pure Freude  
an Wasser*

**GROHE**  
WAVE

29 135

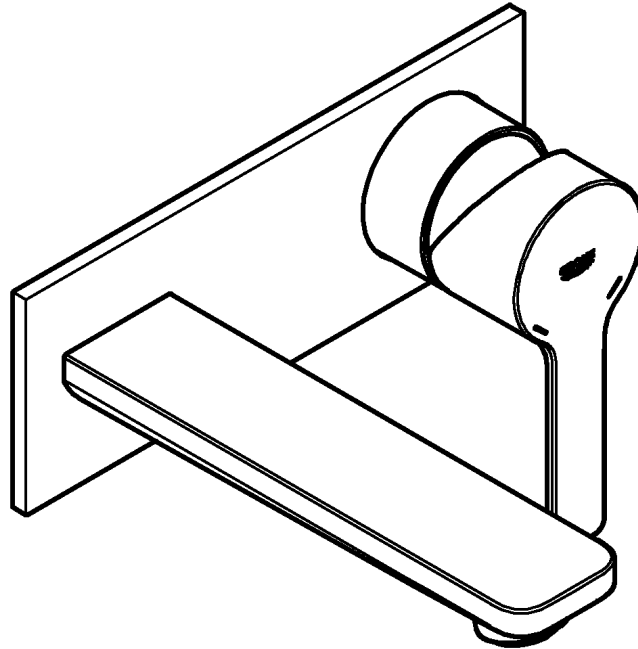

23 839  
29 171

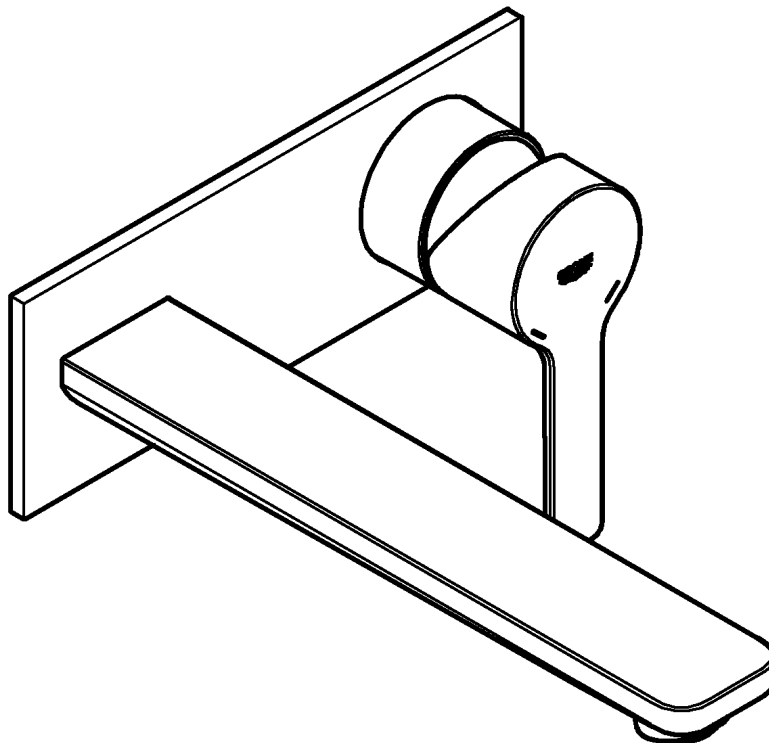



29 135

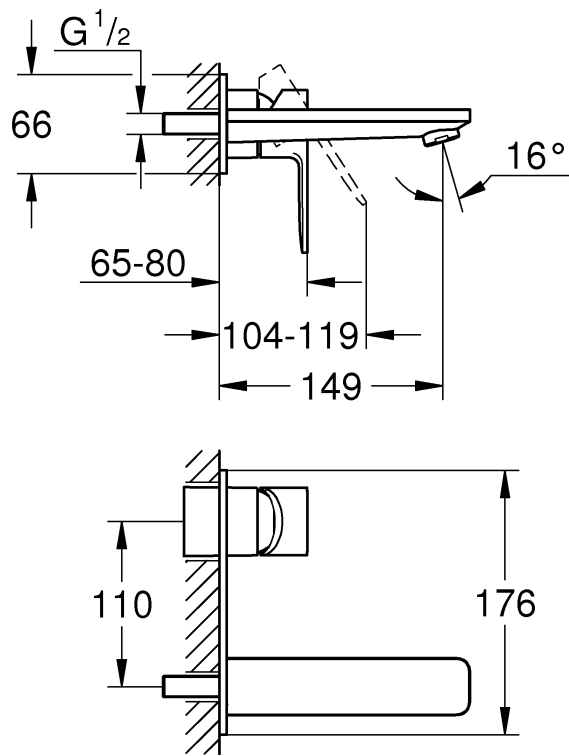

23 839  
29 171

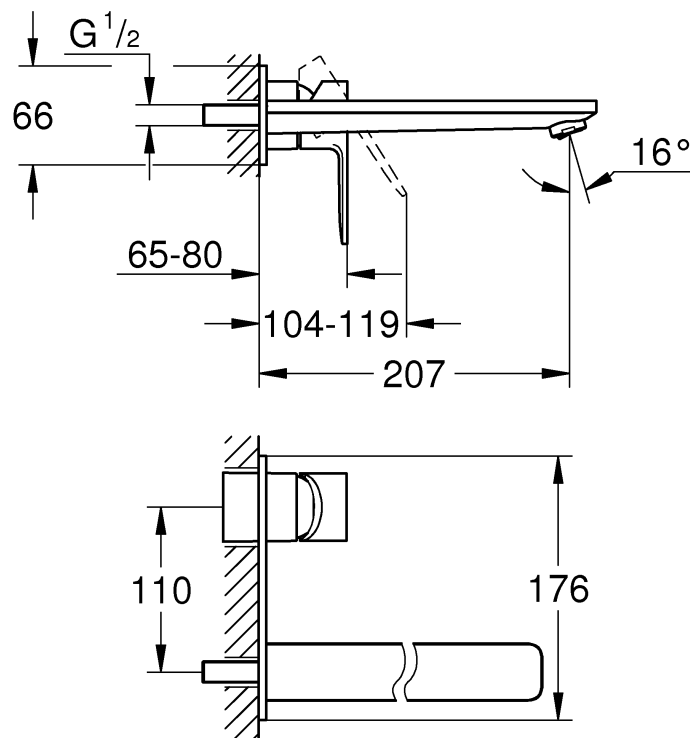

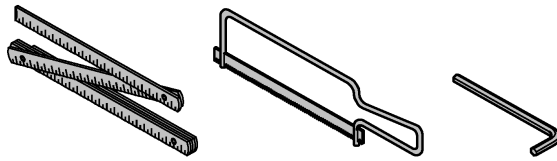

\*19 332  
32mm

1

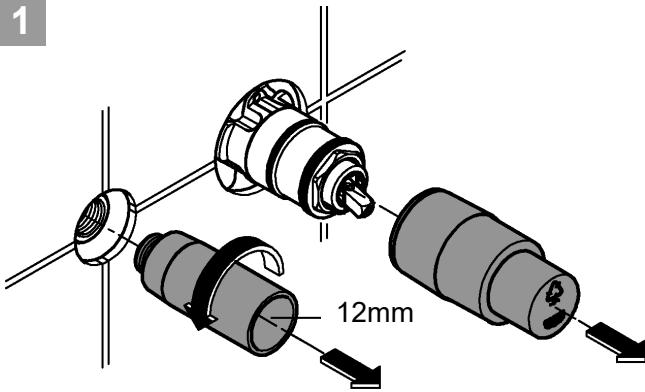

2

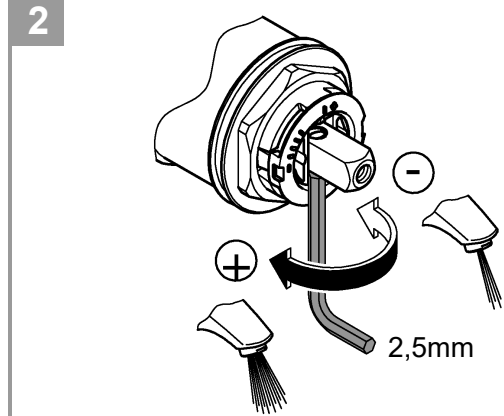

3

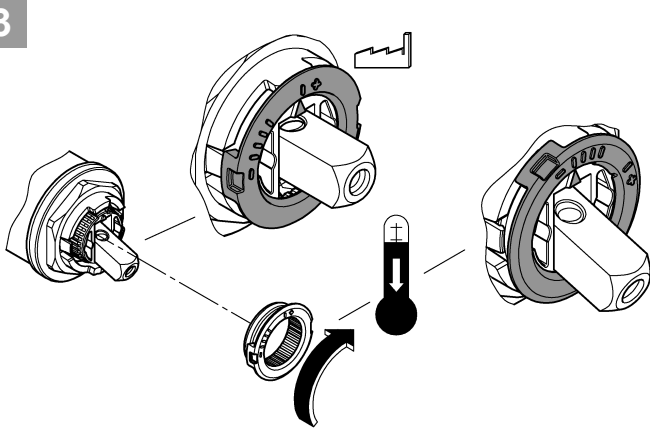

4

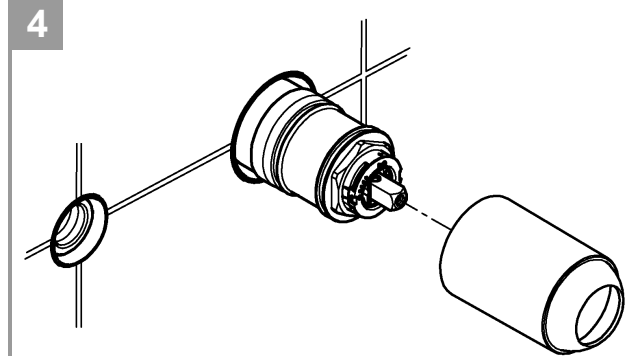

5

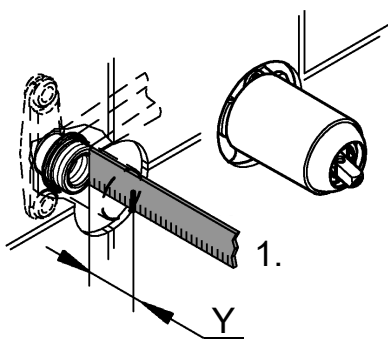

6

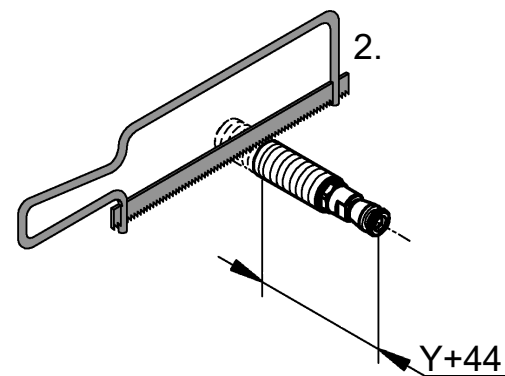
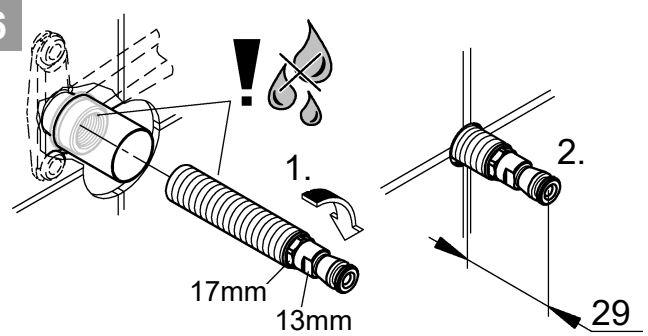

7

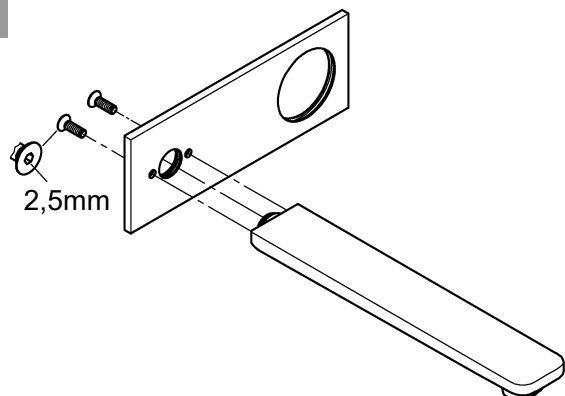

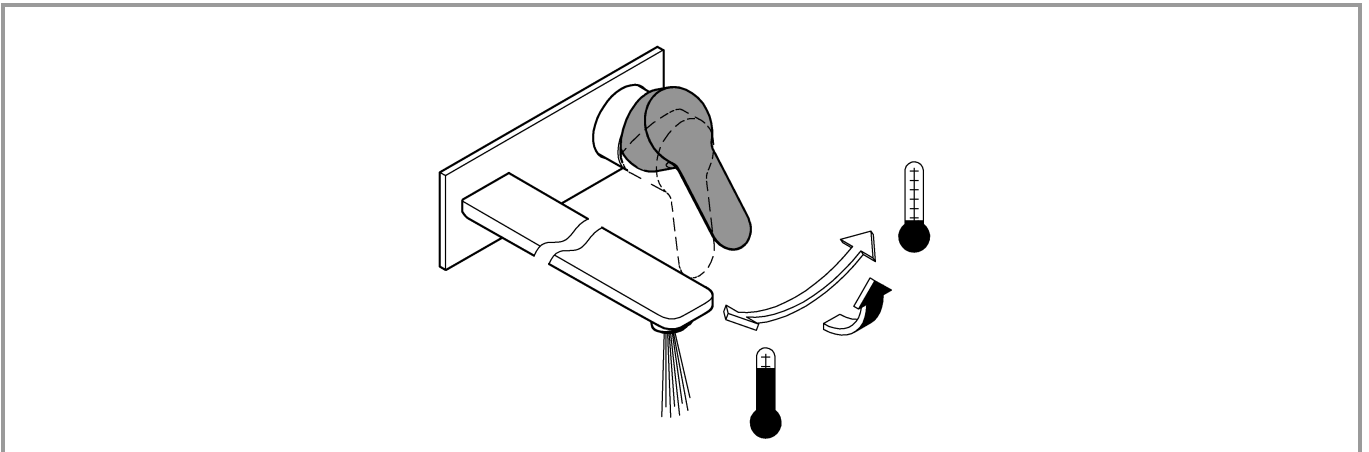
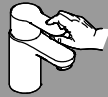
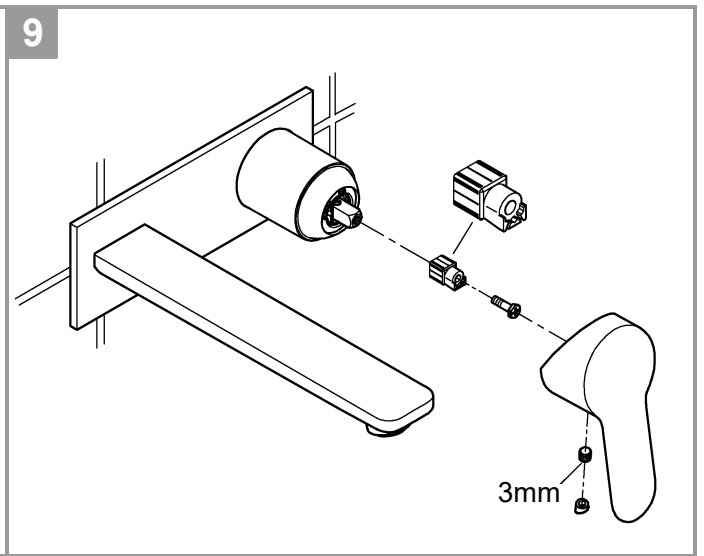
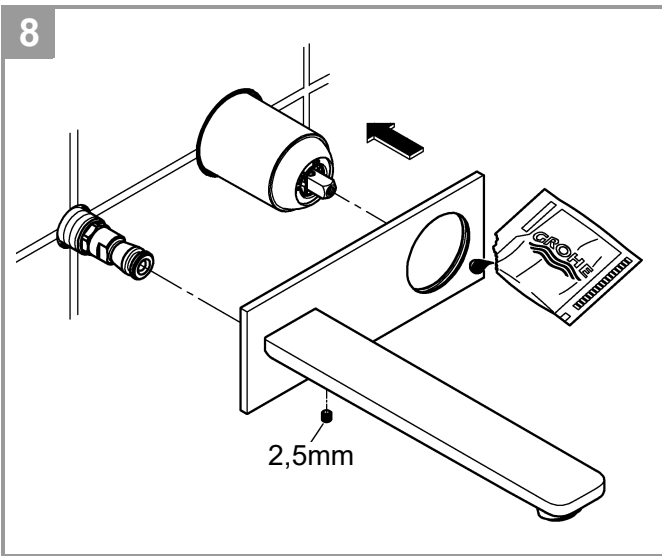

MAINTENANCE

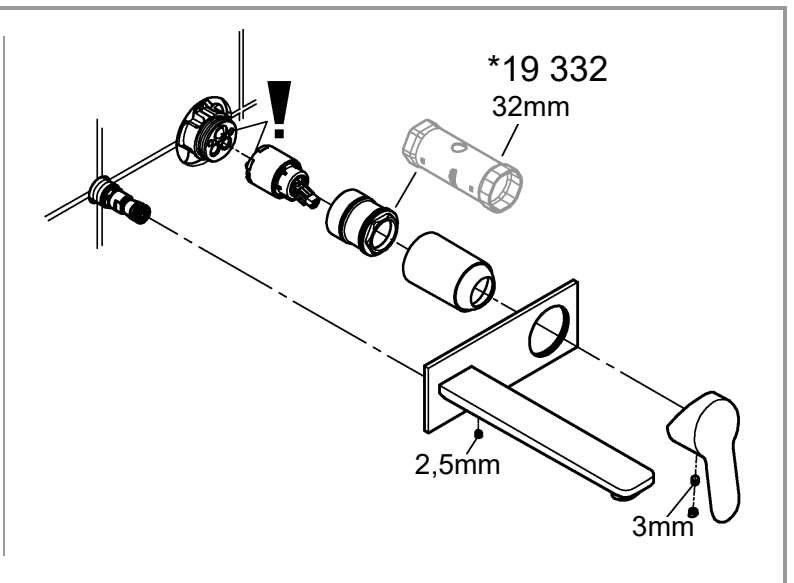
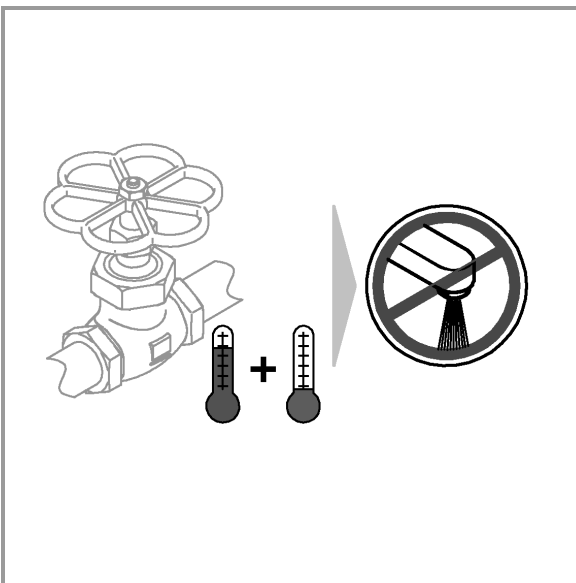

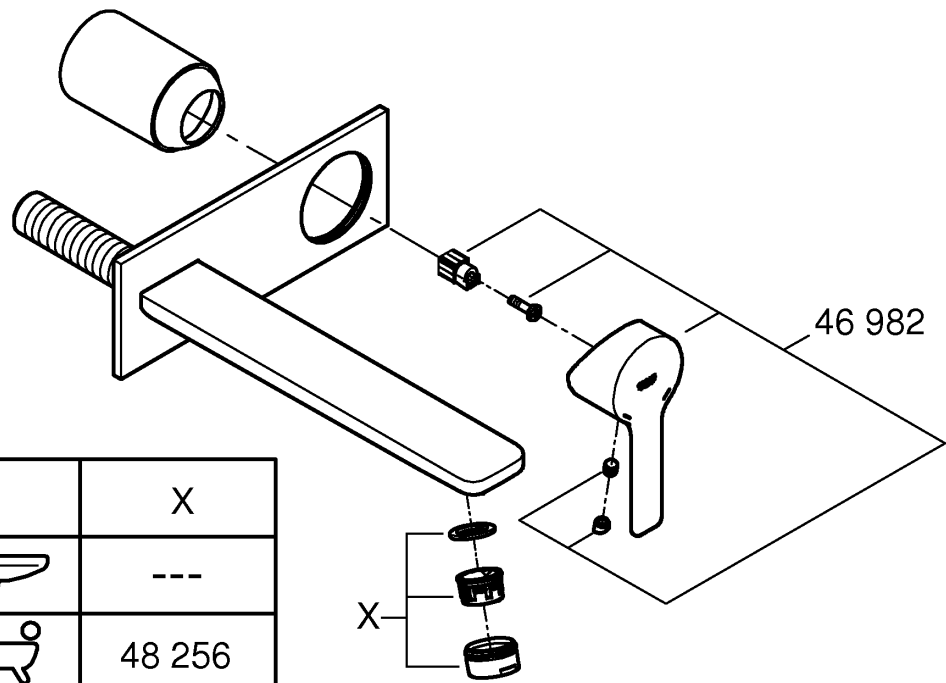
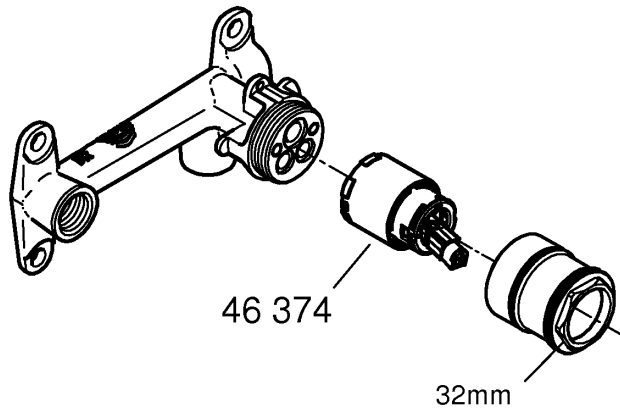

	X
	---
	48 256

*19 332 	32mm 
*46 943 	25 

