

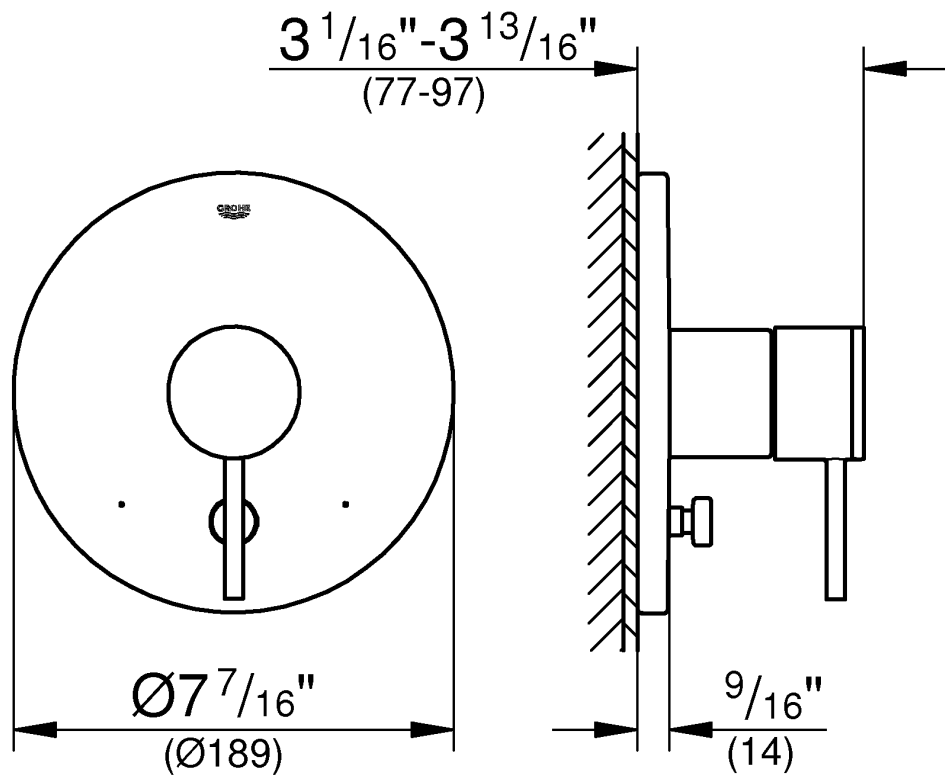

19 867

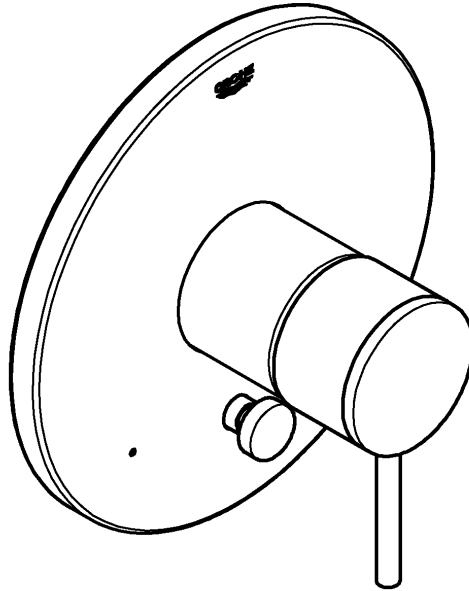



35 016

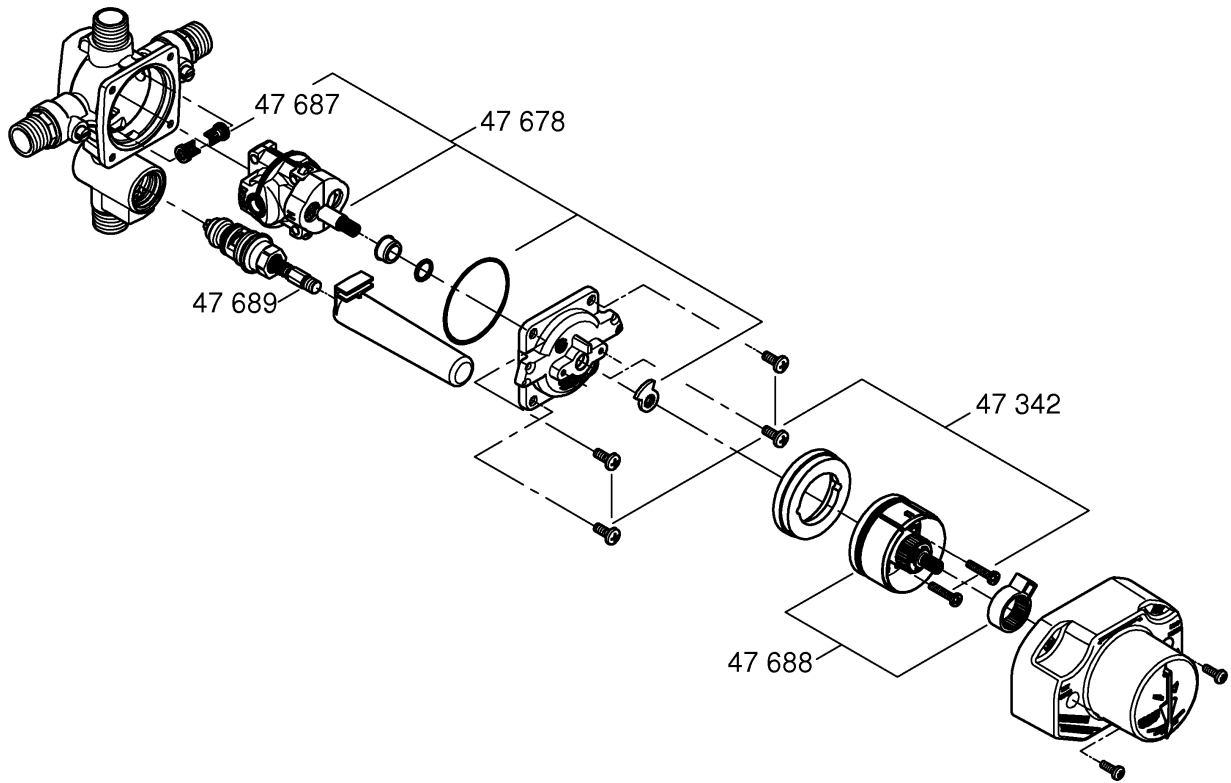

19 867

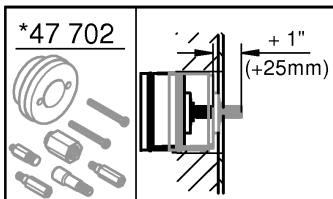
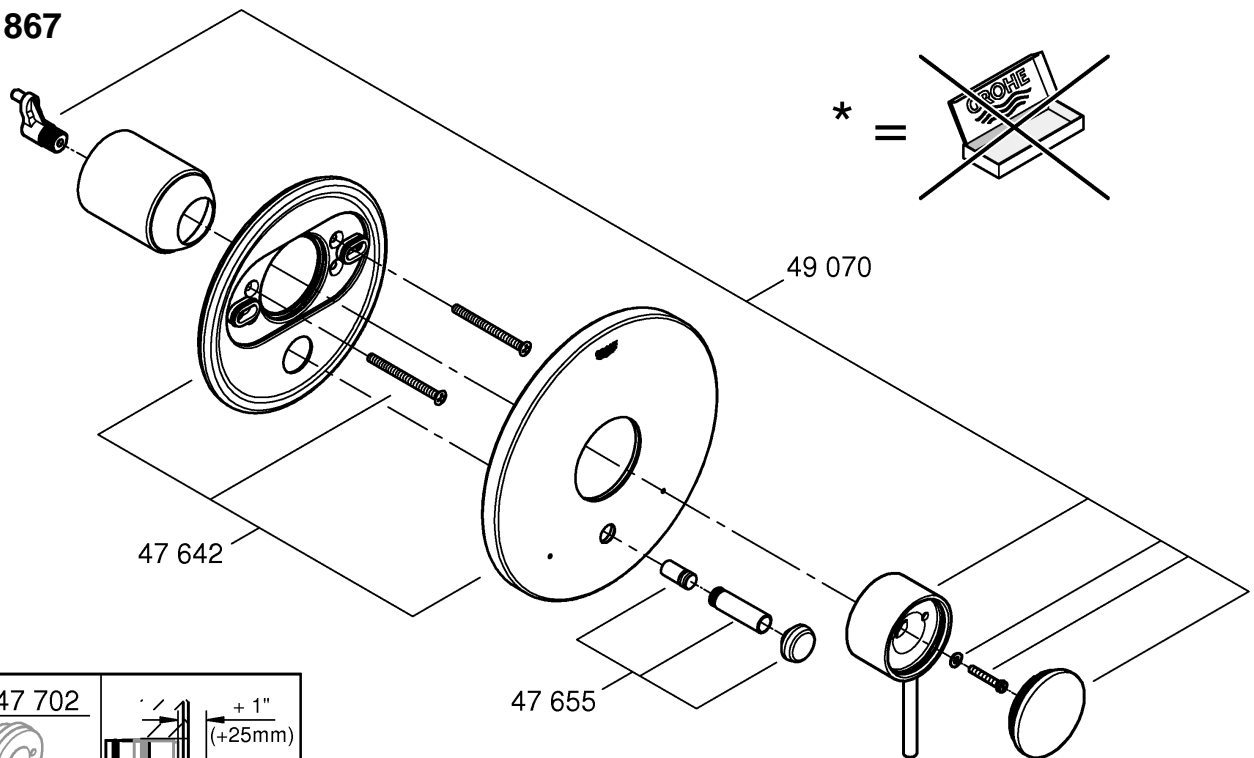

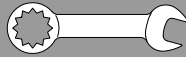
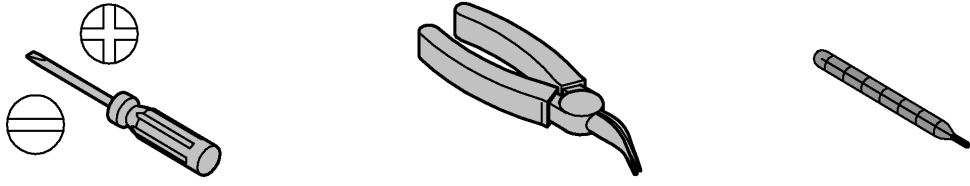

1

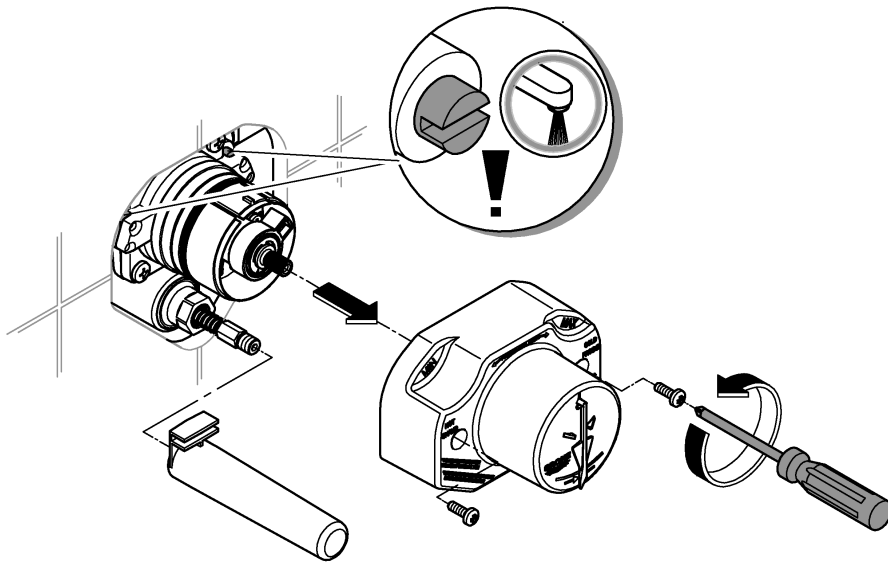

2

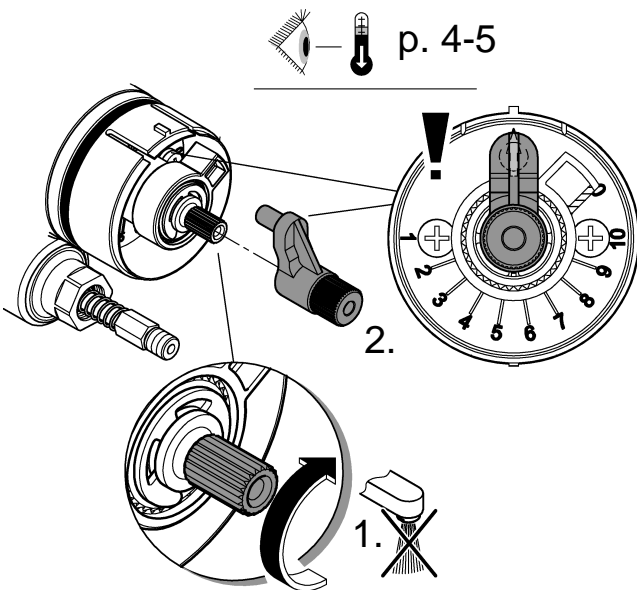

3

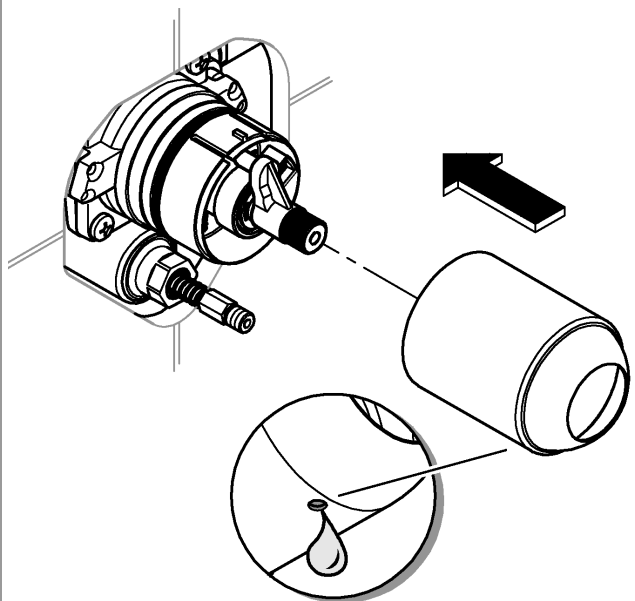



4

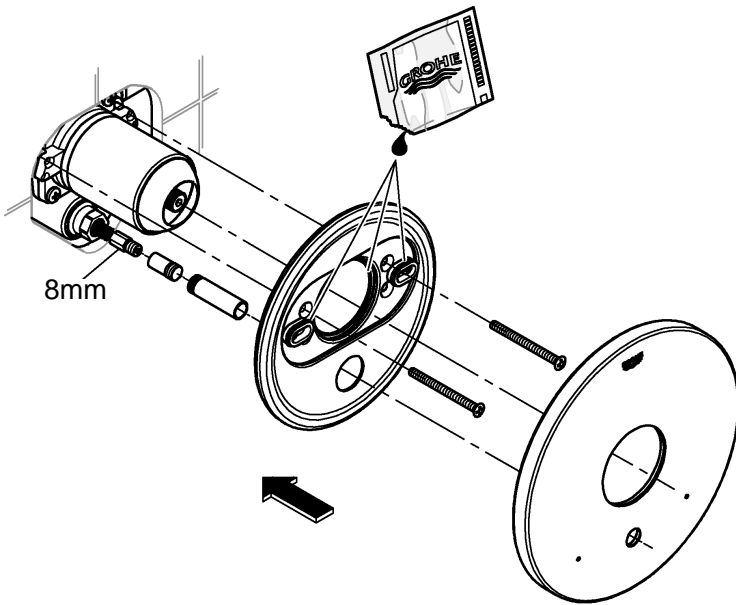

5

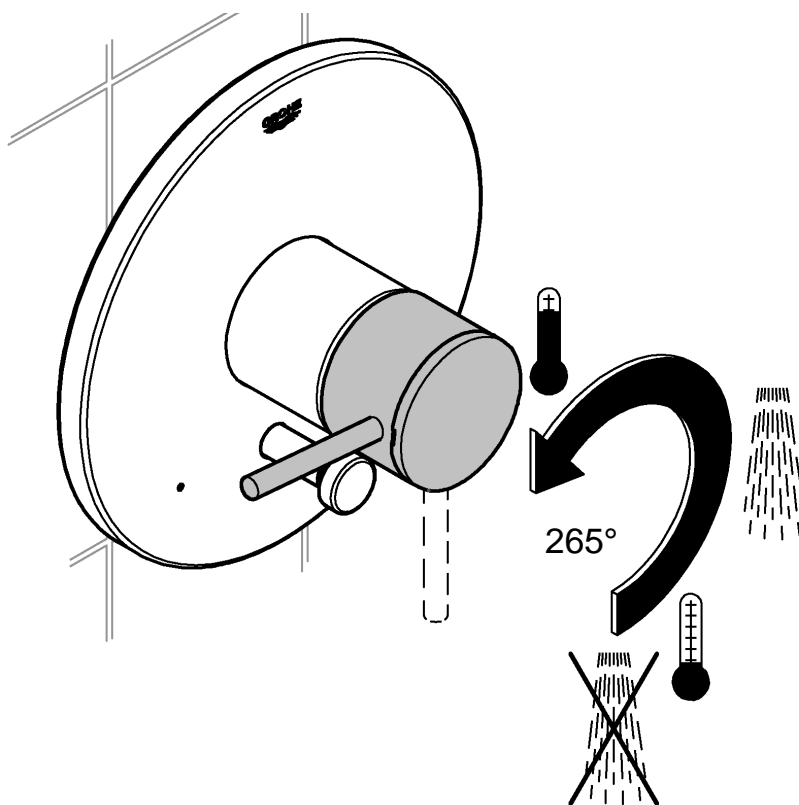
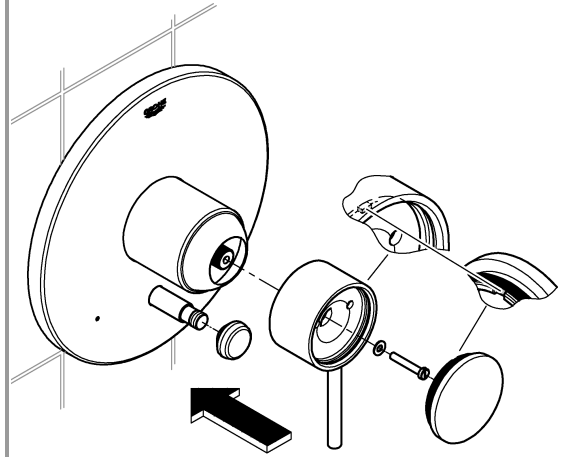

3



1

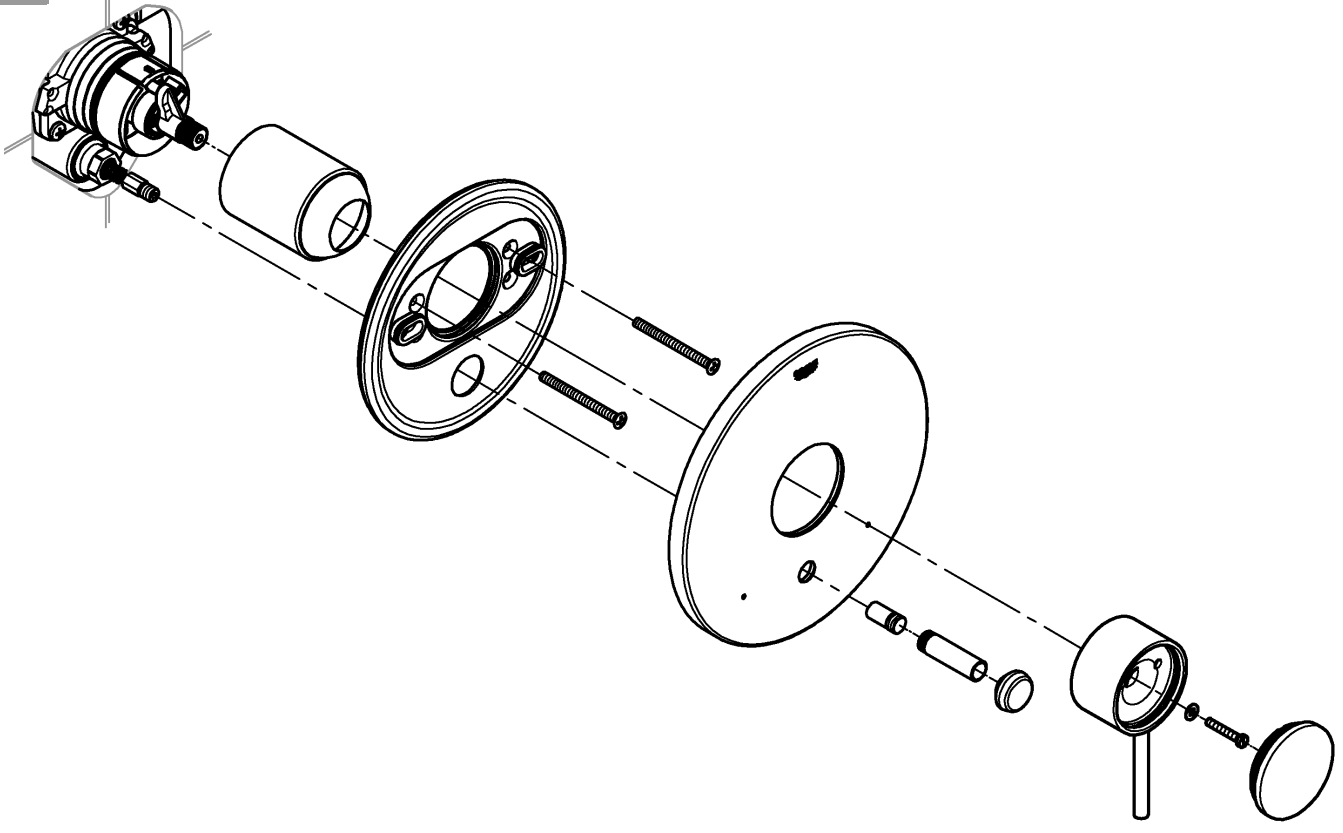

2

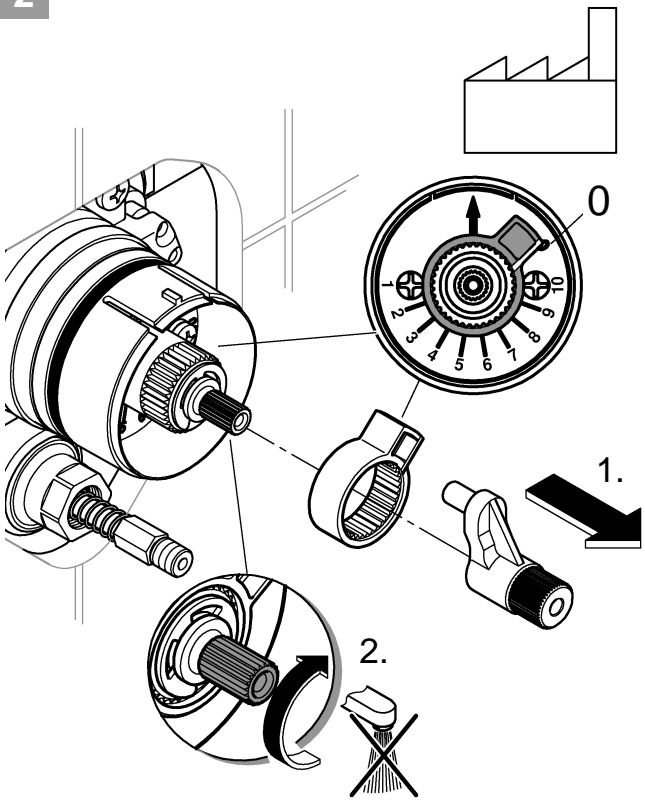

3

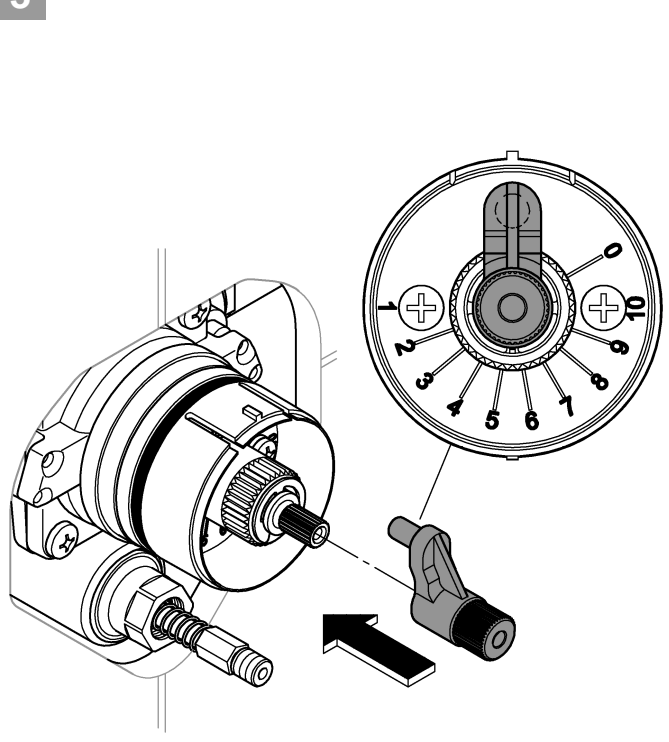



4

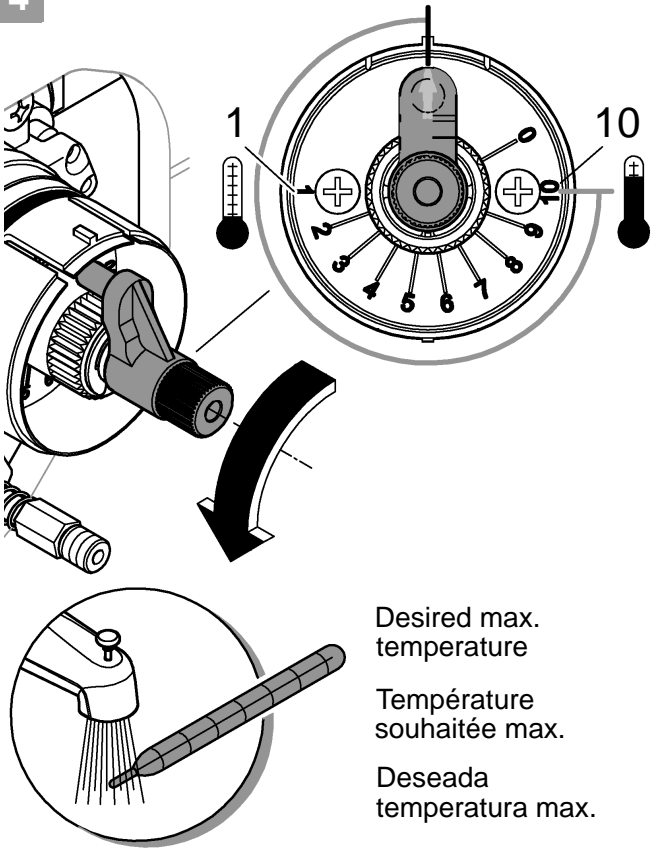

5

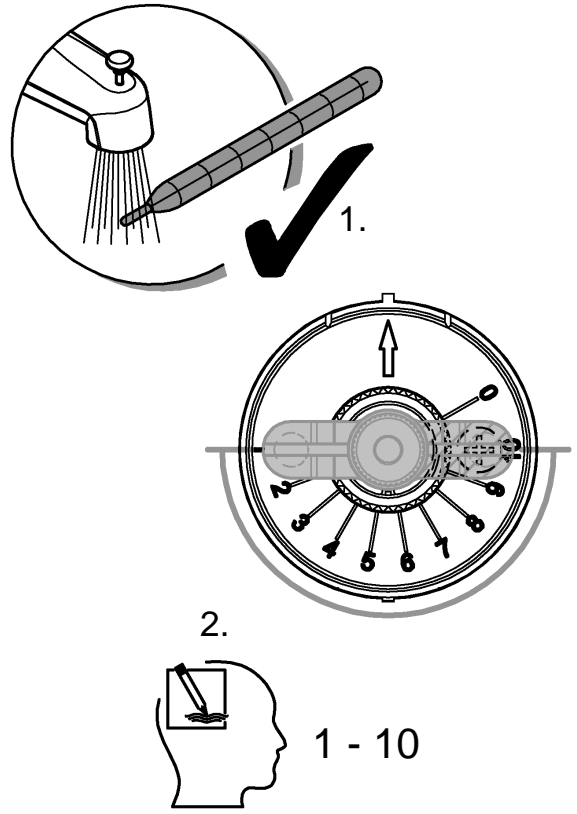

6

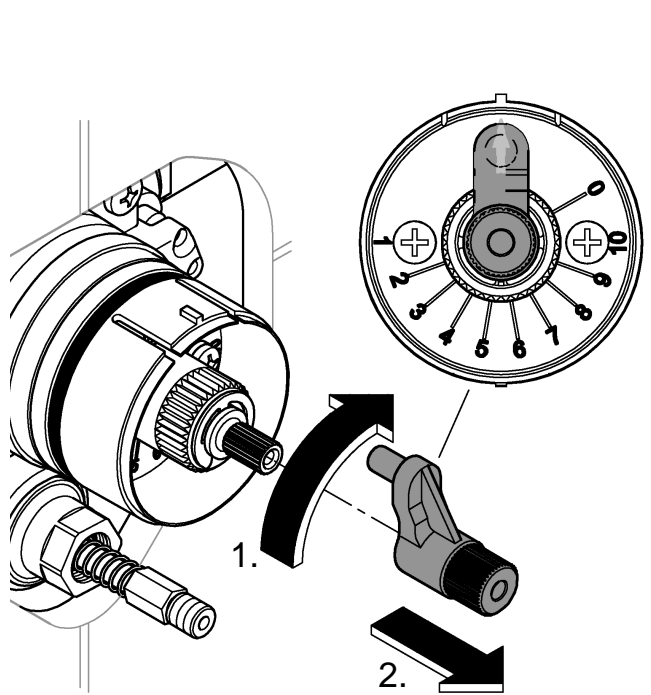

7

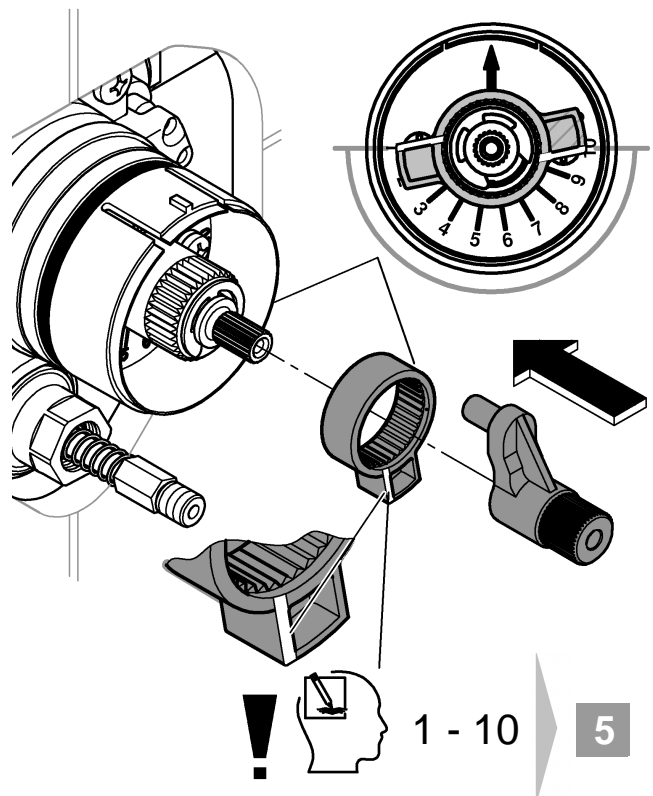

1

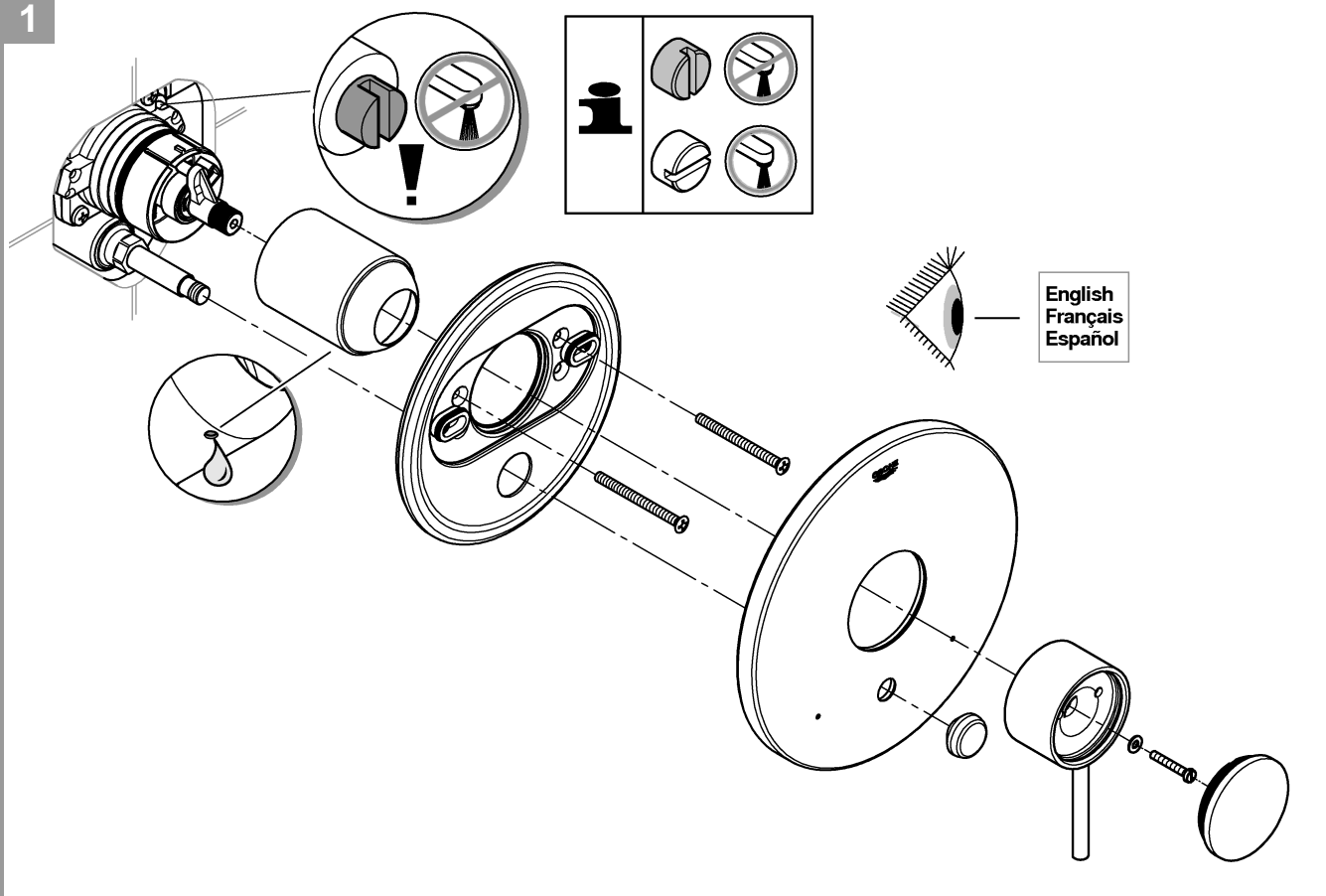

2

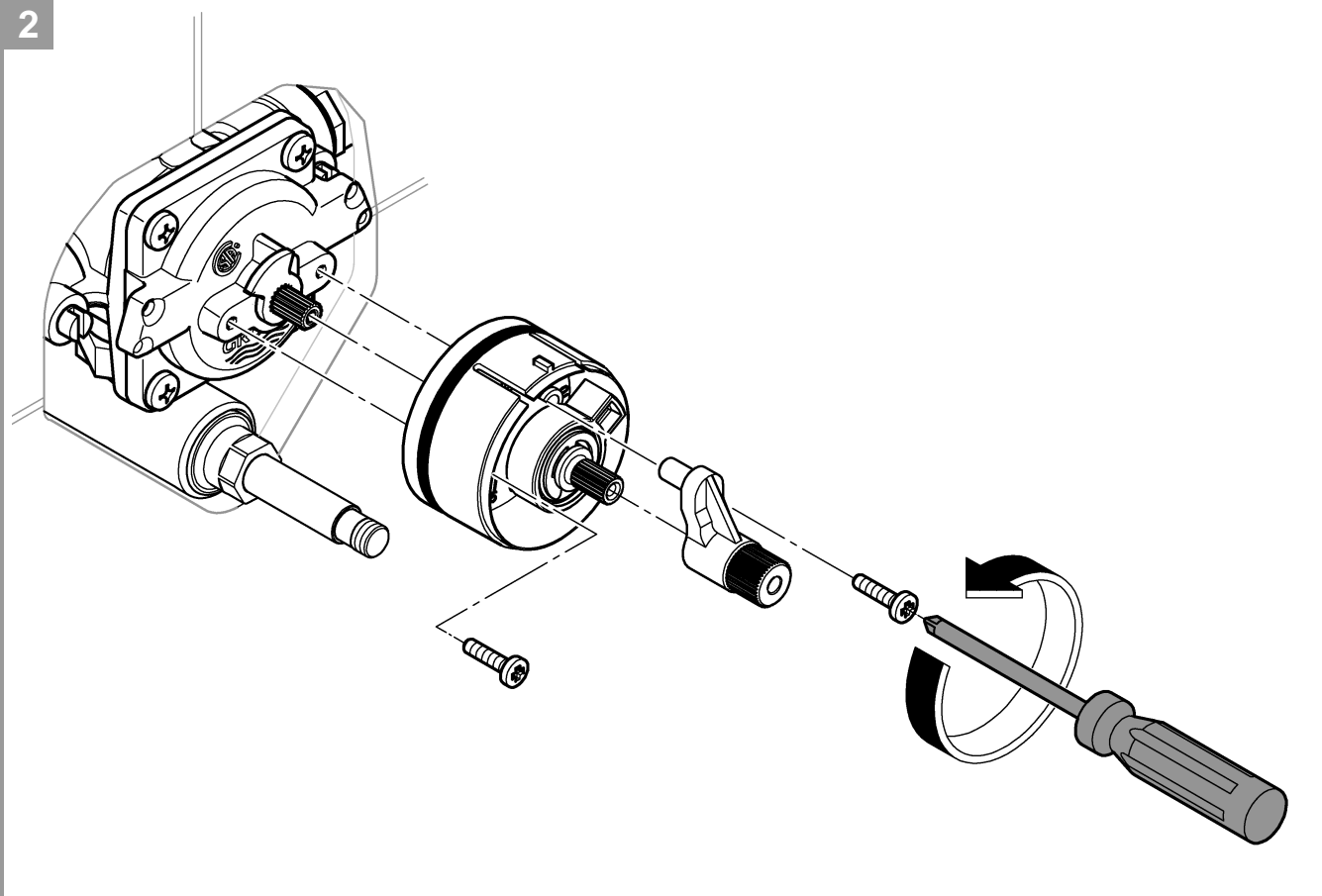

3

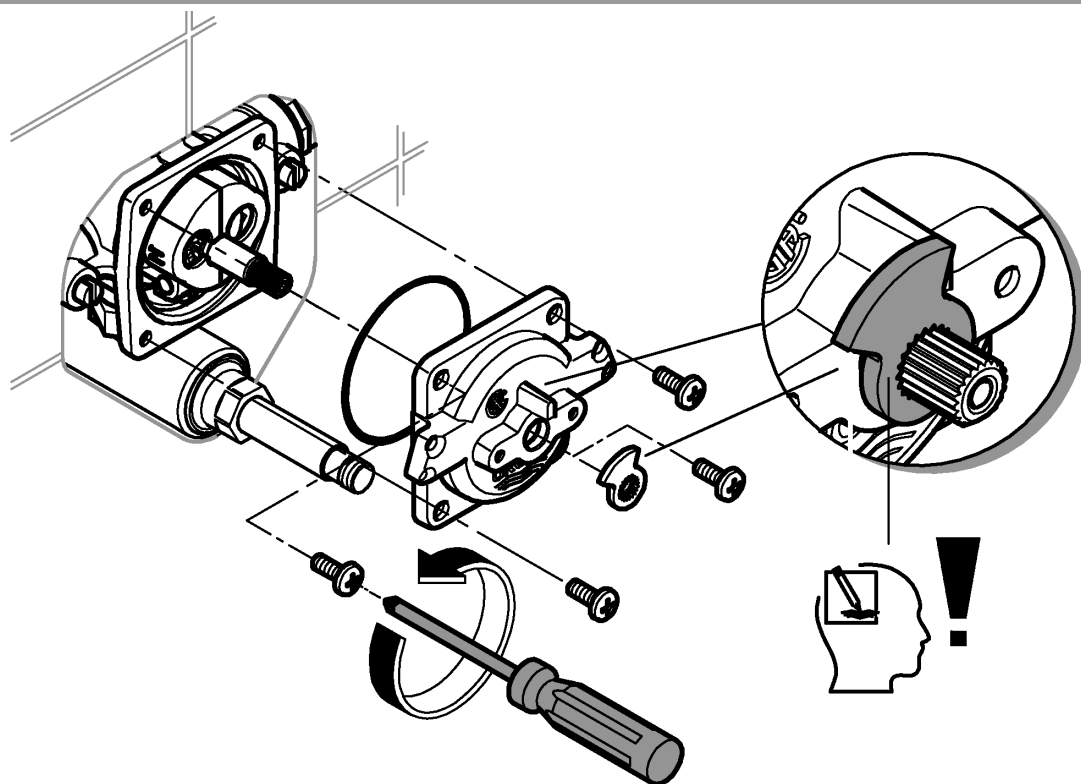

4

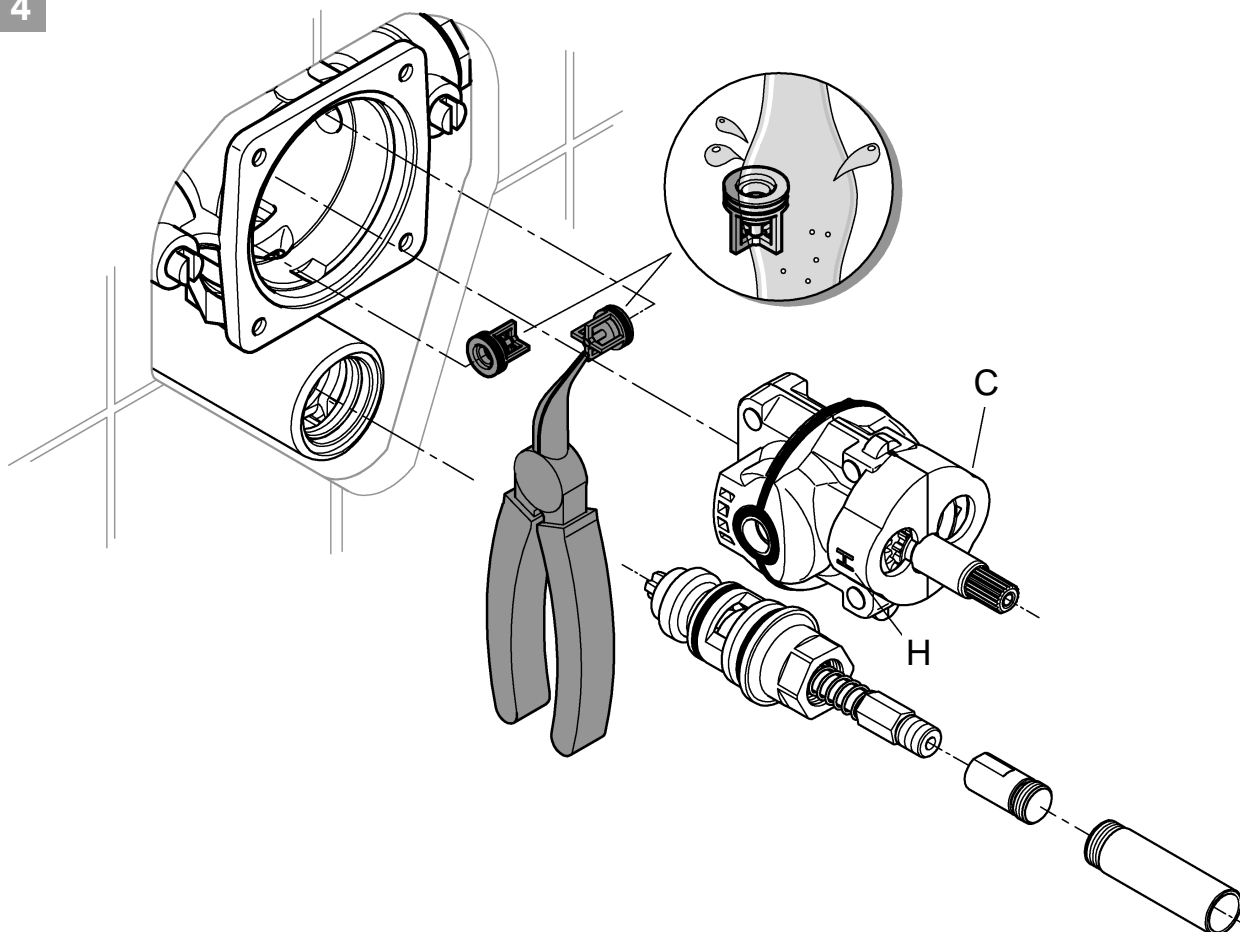



A series of horizontal lines for writing, consisting of 20 evenly spaced lines extending across the width of the page.

English

Flush piping system prior and after installation of faucet thoroughly!

Winterizing the system

It is recommended that the "pressure balancing cartridge" be removed from the valve casting if the system is to be shut off during the winter.

Maintenance

Pull the pressure balancing cartridge out of the valve body noting the location of "H" and "C".

Remove the check valve inserts. If the check valves are removed it is important to reinstall them with the O-ring facing away from the cartridge.

If they are installed incorrectly no water will flow. The pressure balancing cartridge must be replaced as a complete unit.

Reassemble in reverse order.

Ensure that the hot "H" and cold "C" markings are on the correct side.



Be sure that the stop ring is installed in the noted position.

Notes:

- Major pressure differences between cold and hot water supply should be avoided.
- To be installed according to local codes and regulations.

Replacement parts, see page 1 (* = special accessories).

Care

Instructions for care of this faucet will be found in the Limited Warranty supplement.

Français

Bien rincer les canalisations avant et après l'installation!

Hivernisation du système

Il est recommandé de retirer la "cartouche d'équilibrage de pression" du boîtier de robinet si le système doit être fermé pendant l'hiver.

Maintenance

Sortir la cartouche d'équilibrage de pression du corps de robinet en notant la position des marques "H" et "C".

Retirer les inserts de clapet anti-retour. Si les clapets anti-retour sont retirés, il est important de bien les reposer avec le joint torique orienté à l'opposé de la cartouche.

S'ils sont montés de manière incorrecte, l'eau ne coulera pas. La cartouche d'équilibrage de pression doit être remplacée en bloc.

Le remontage se fait dans l'ordre inverse.

S'assurer que les marques "H" (chaud) et "C" (froid) sont du bon côté.



S'assurer que la bague de butée est posée dans la position indiquée.

Remarques:

- Il convient d'éviter toute différence de pression importante entre l'alimentation en eau chaude froide et chaude.
- A installer conformément aux prescriptions et réglementations locales.

Pièces de rechange, voir page 1 (* = accessoires spéciaux).

Entretien

Vous trouverez les instructions d'entretien de ce mitigeur dans le supplément Garantie Limitée.

Español

¡Purgar a fondo el sistema de tuberías antes y después de la instalación!

Adaptación del sistema a las condiciones invernales

Se recomienda extraer el "cartucho compensador de presión" de la carcasa de la válvula si se corta el suministro del sistema durante el invierno.

Mantenimiento

Saque el cartucho compensador de presión existente del cuerpo de la válvula y tome nota de las posiciones de las marcas "H" y "C".

Desmonte las válvulas antirretorno insertables. Si se desmontan las válvulas antirretorno, es importante volver a instalarlas con la junta toroidal situada en el extremo opuesto al cartucho.

Si se instalan incorrectamente no circulará el agua. El cartucho compensador de presión constituye una unidad que debe ser cambiada de forma completa.

Para realizar el montaje, proceda siguiendo el orden inverso.

Asegúrese de que agua caliente "H" y agua fría "C" se encuentren en el lado correcto.



Asegúrese de que el anillo de tope se instala en la posición anotada.

Notas:

- Deberán evitarse las diferencias de presión entre las acometidas del agua fría y del agua caliente.
- A ser instalado conforme a códigos y reglamentos locales.

Componentes de sustitución, véase la página 1 (* = accesorios especiales).

Cuidados periódicos

En el suplemento Garantía a Limitada encontrará las instrucciones relativas al cuidado de esta batería.

USA

& +1 800 4447643
us-customerservice@grohe.com

www.grohe.com



CDN

& +1 888 6447643
info@grohe.ca