

ESSENCE NEW

DESIGN + ENGINEERING
GROHE GERMANY

99.1046.031/ÄM 241523/11.17

www.grohe.com

Pure Freude an Wasser



29 133

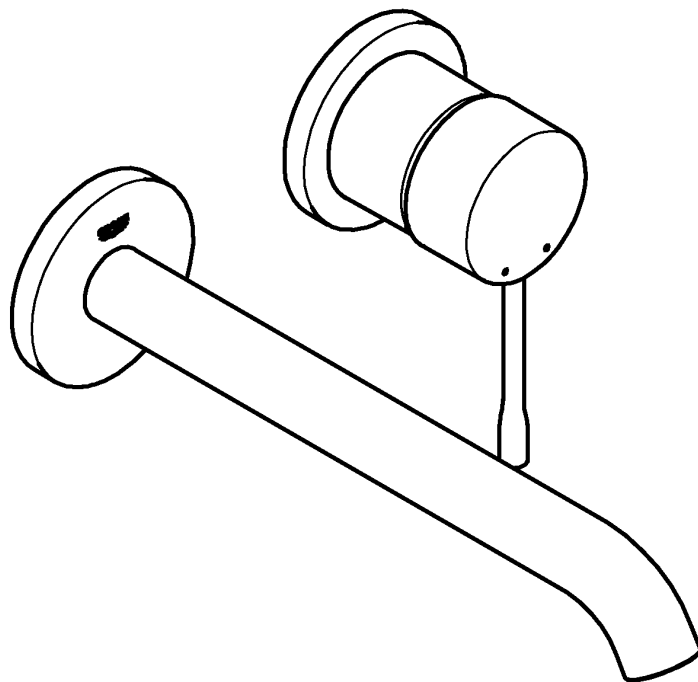

29 134

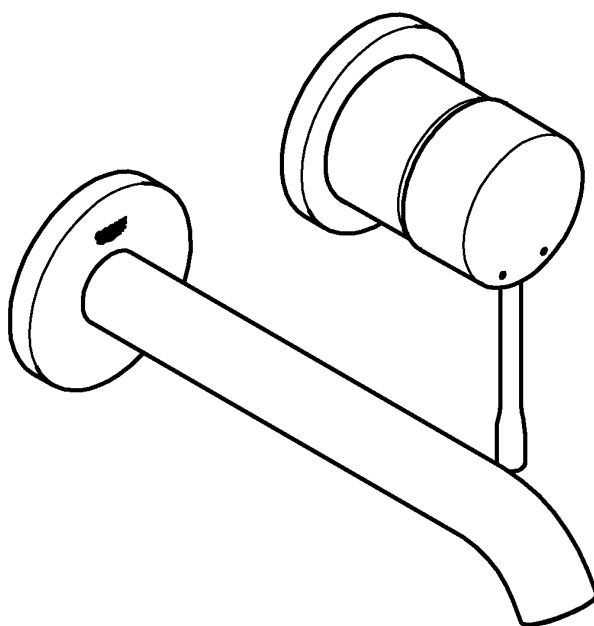

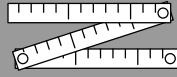

29 133

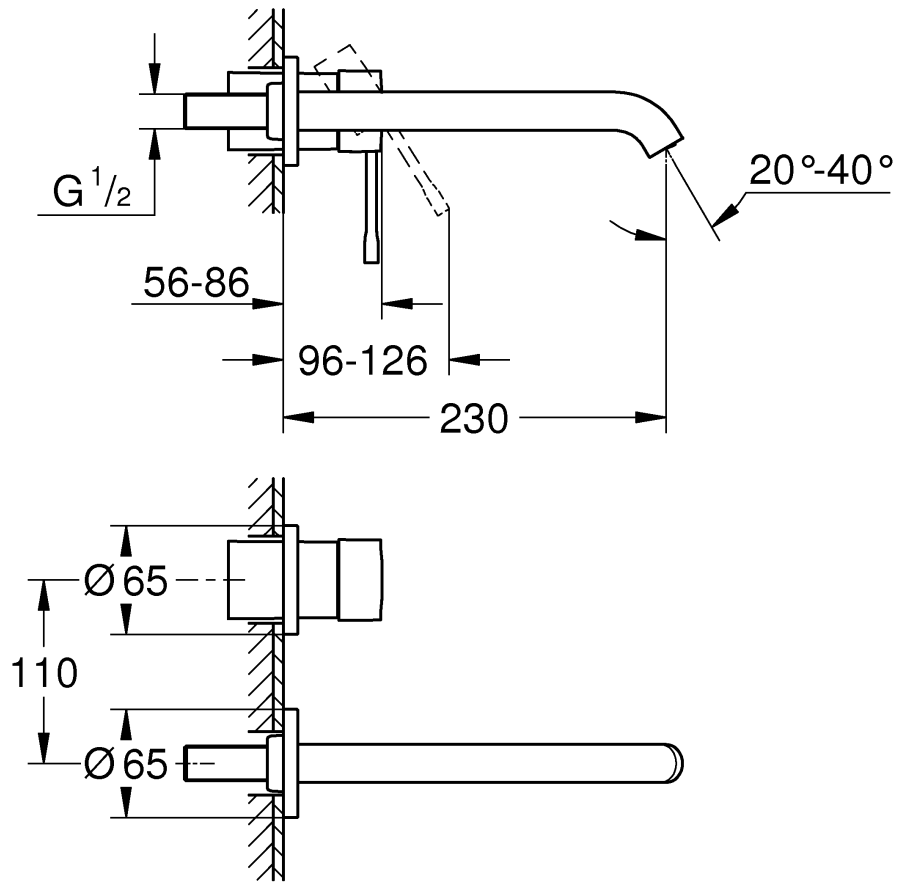

29 134

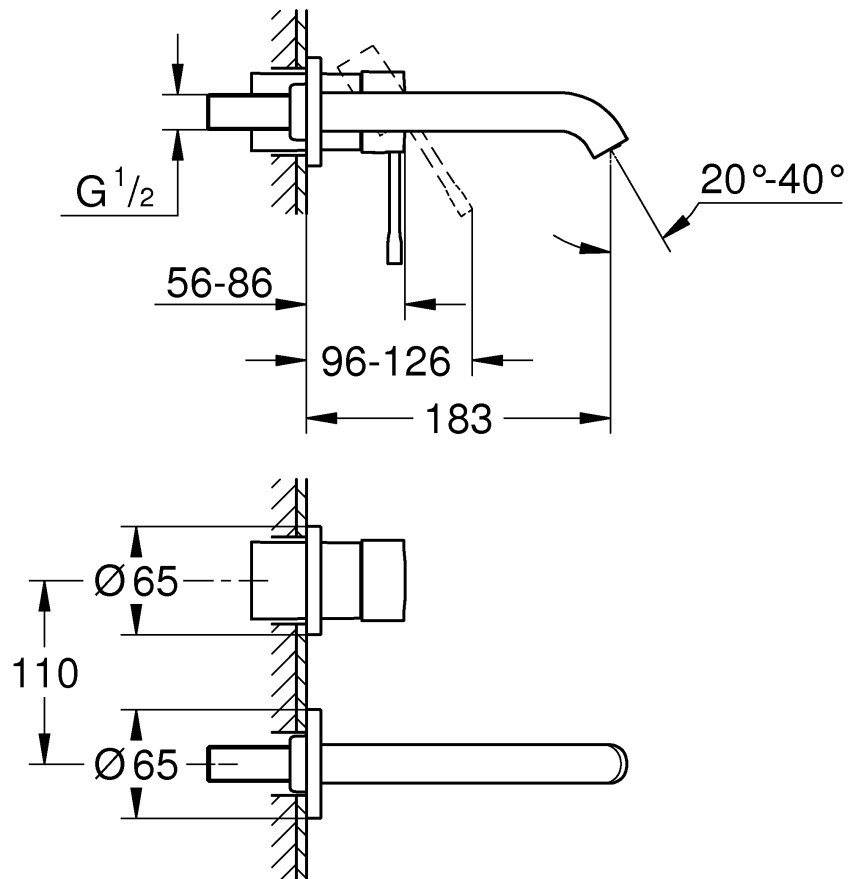

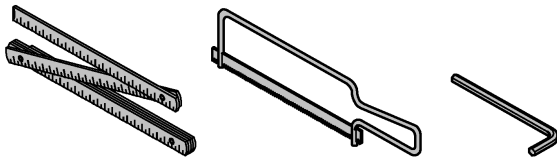

*19 332



32mm

1

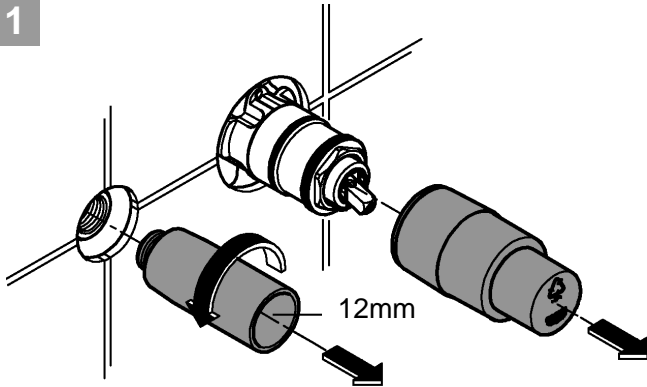

2

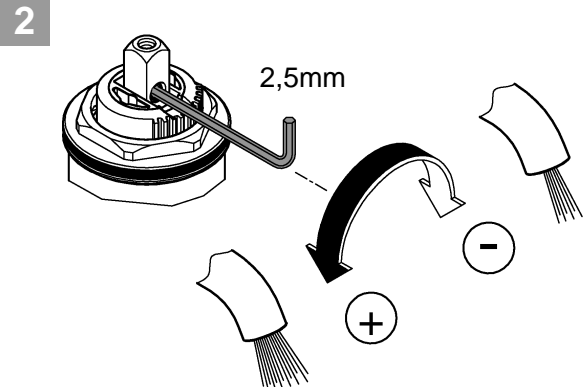

3

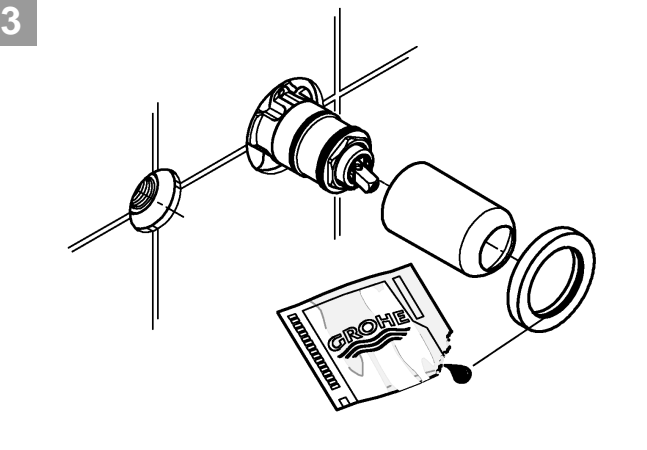

4

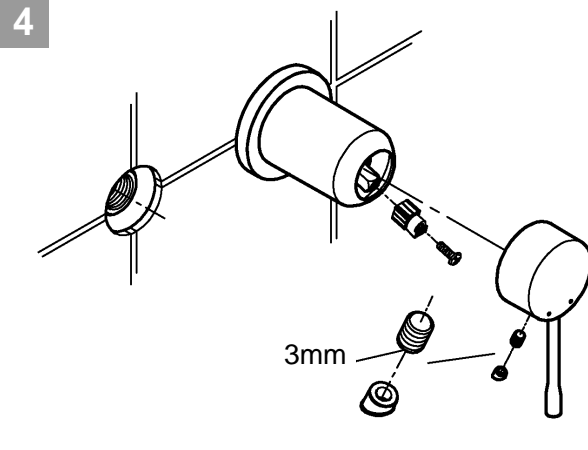

5

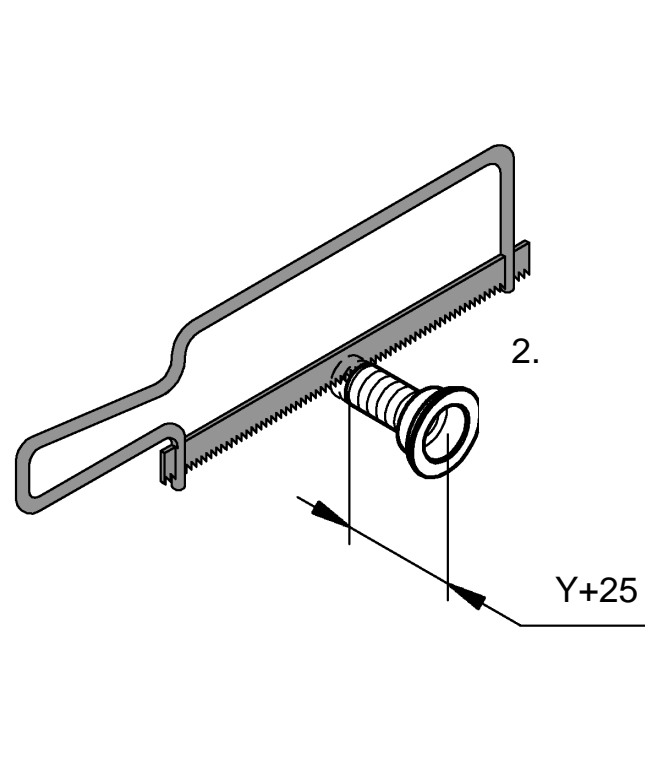
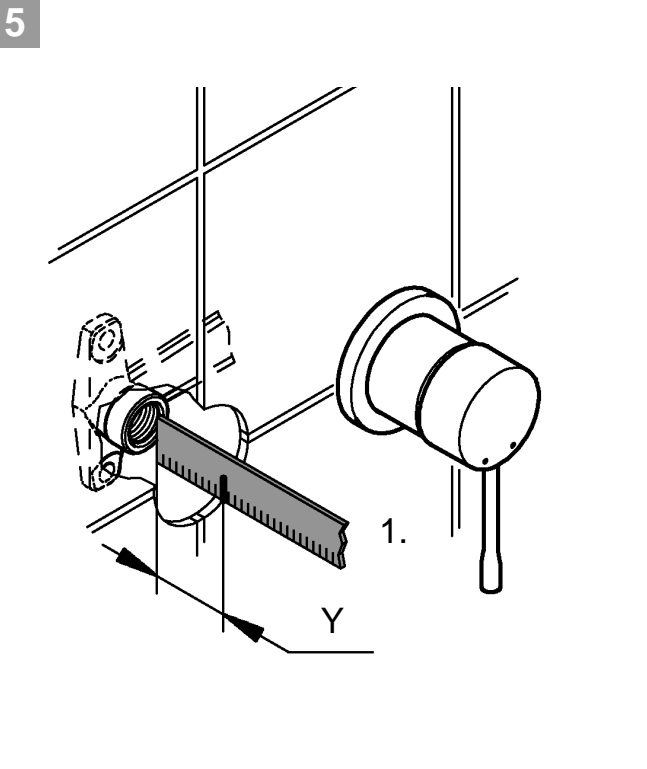

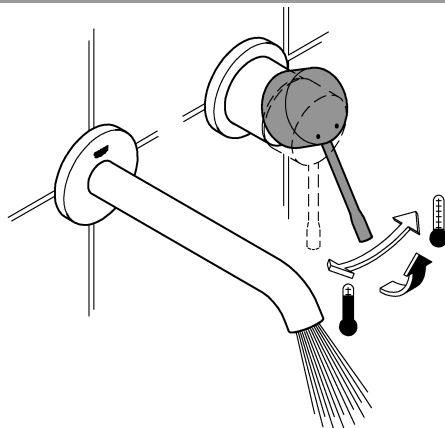
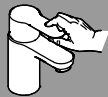
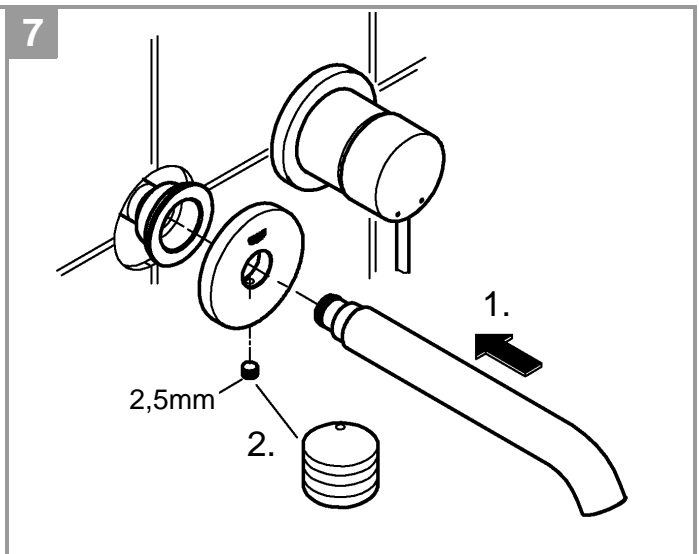
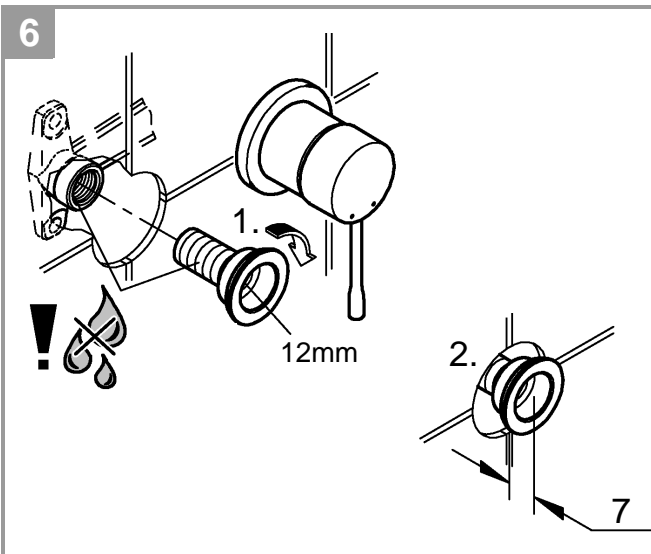

MAINTENANCE 

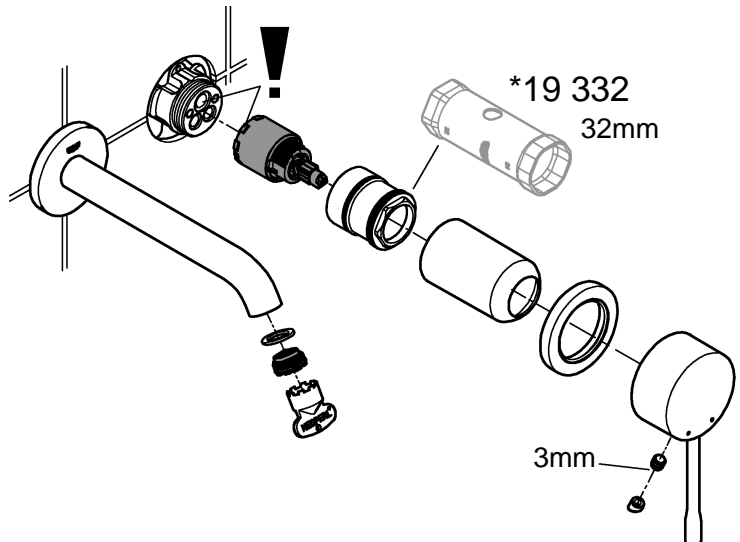
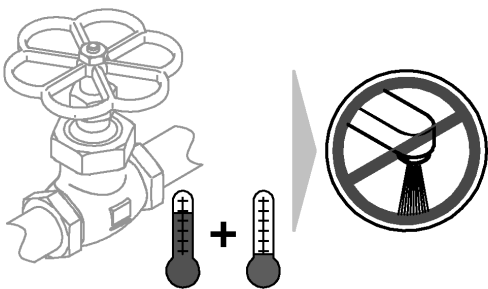



23 842

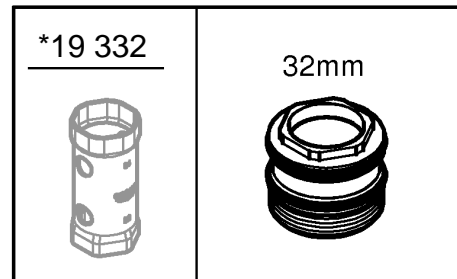
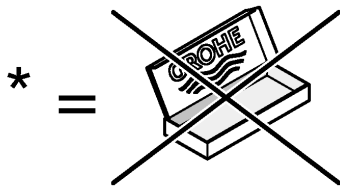
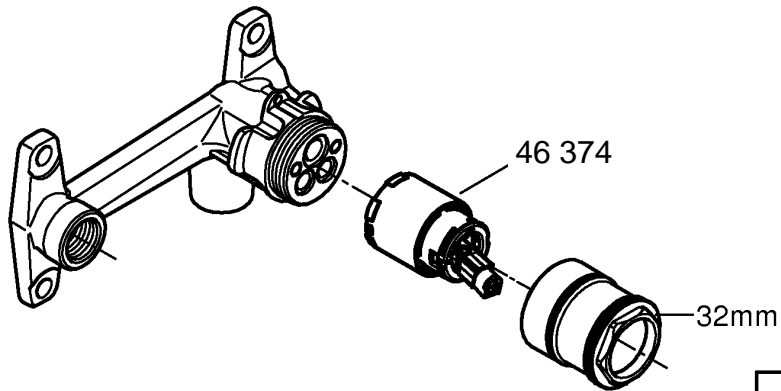

29 133
29 134

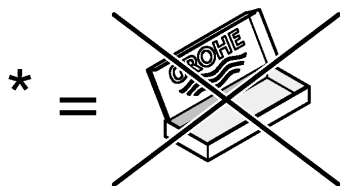
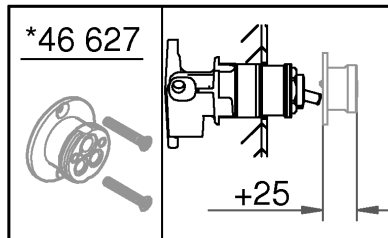
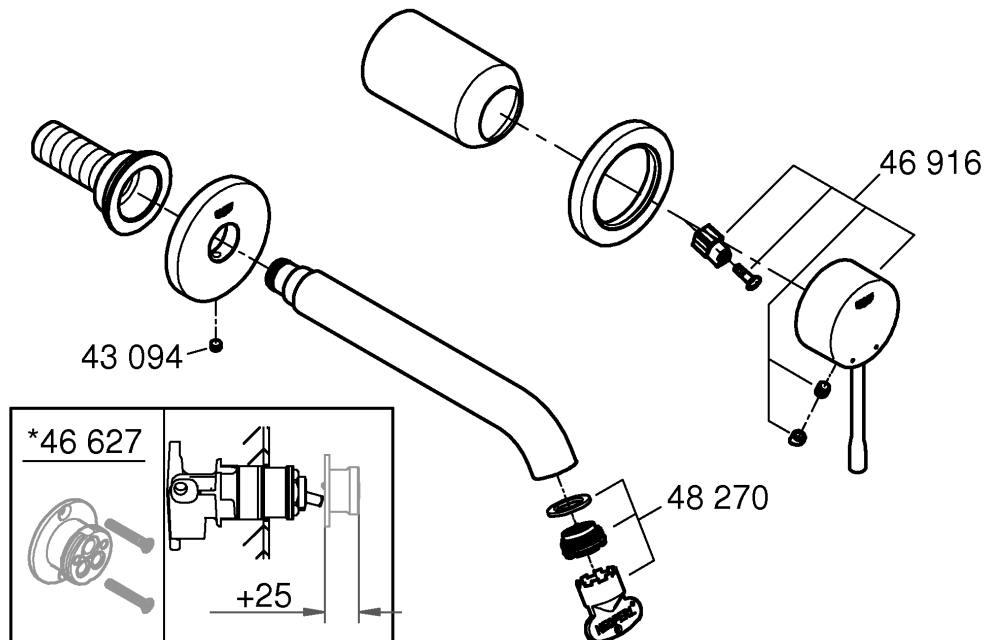

Application

- for basin

Specification:

- Flow rate at 300 kPa flow pressure approx. 5 L/min



Installation

Remove the fitting template, see Fig. [1].

Flush piping system prior and after installation of fitting thoroughly (Consider EN 806)!

This product must be installed in conformance with local codes e.g. AS/NZS 3500 series of standard!

Flow rate limiter

This mixer is fitted with a flow rate limiter, permitting an infinitely individual variable reduction in the flow rate.

The highest possible flow rate is set by the factory before despatch.

The use of flow rate limiters in combination with hydraulic instantaneous water heaters is not recommended.

For commissioning, see Fig. [2].

Installation, see Fig. [3] - [4].

Install spout, see Figs. [5] - [7].

Determine dimension "Y" from upper edge of concealed mixer housing to the face of tiles.

Cut connection nipple to length so that the installation dimension is "Y" + 25mm.

Using a 12mm allen key, screw the connection nipple into the concealed housing so that the installation dimension is 7mm. Tighten spout from below using a 2.5mm allen key.

Open cold and hot-water supply and check connections for watertightness!



Check fitting for correct operation.



Maintenance

Inspect and clean all parts, replace as necessary and grease with special grease.

Shut off cold and hot water supply!



Replacement parts (* = special accessories).

Care

For directions on the care of this fitting, refer to the accompanying Care Instructions.

AUS

Reece Australia Pty Ltd
118 Burwood Hwy
Burwood VIC 3125

Tel.: +61 3 9274 0000
Email: admin@reece.com.au



NZ

Robertson
25 Vestey Drive
Mt Wellington, Auckland

Tel.: +64 9 5730490
Email: sales@robertson.co.nz