

F-DIGITAL DELUXE
DESIGN + ENGINEERING
GROHE GERMANY

99.0186.131/ÄM 232677/02.18

www.grohe.com

Pure Freude an Wasser



36 395
36 396

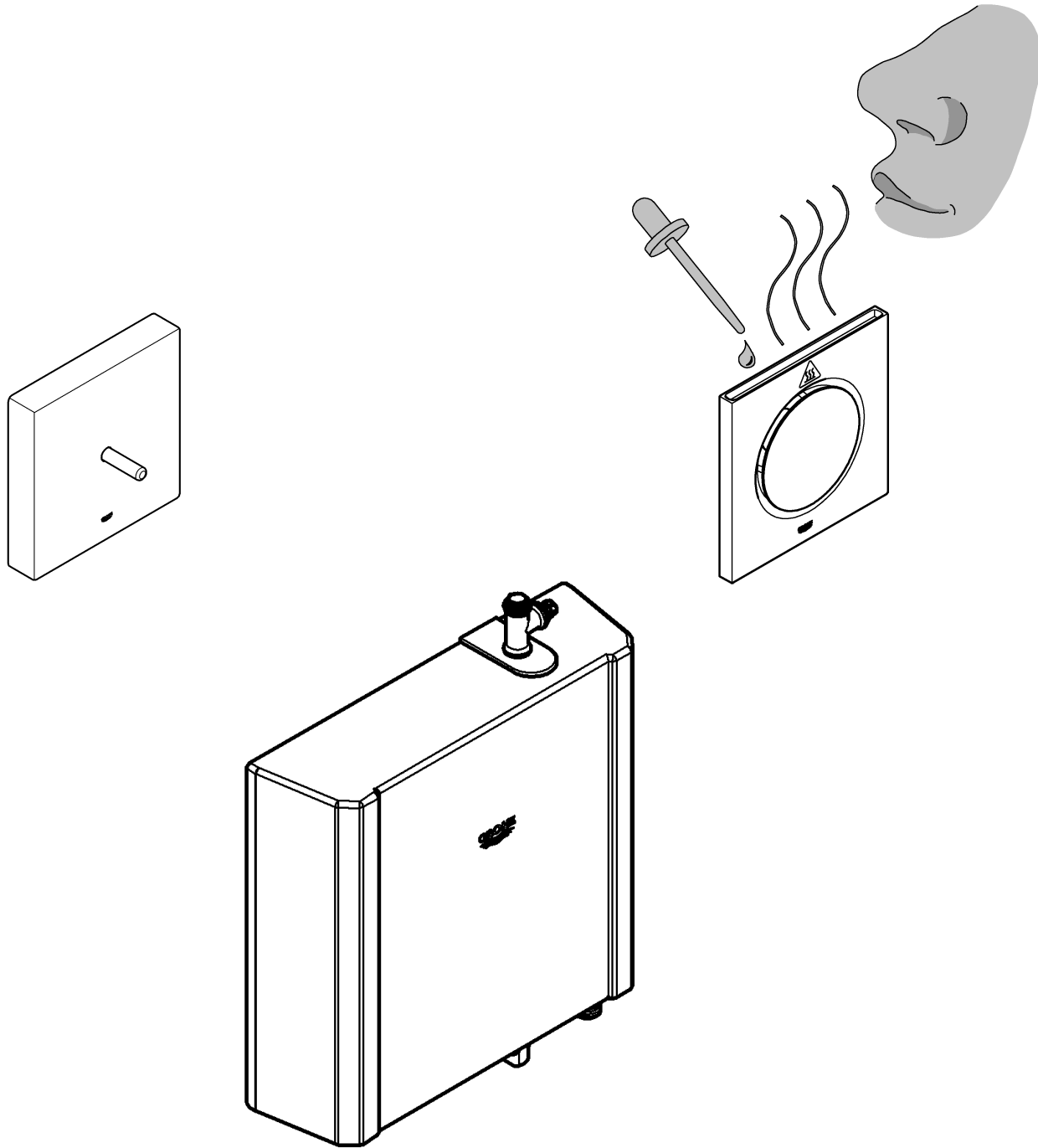

ⒸN 1

ⒸB 3

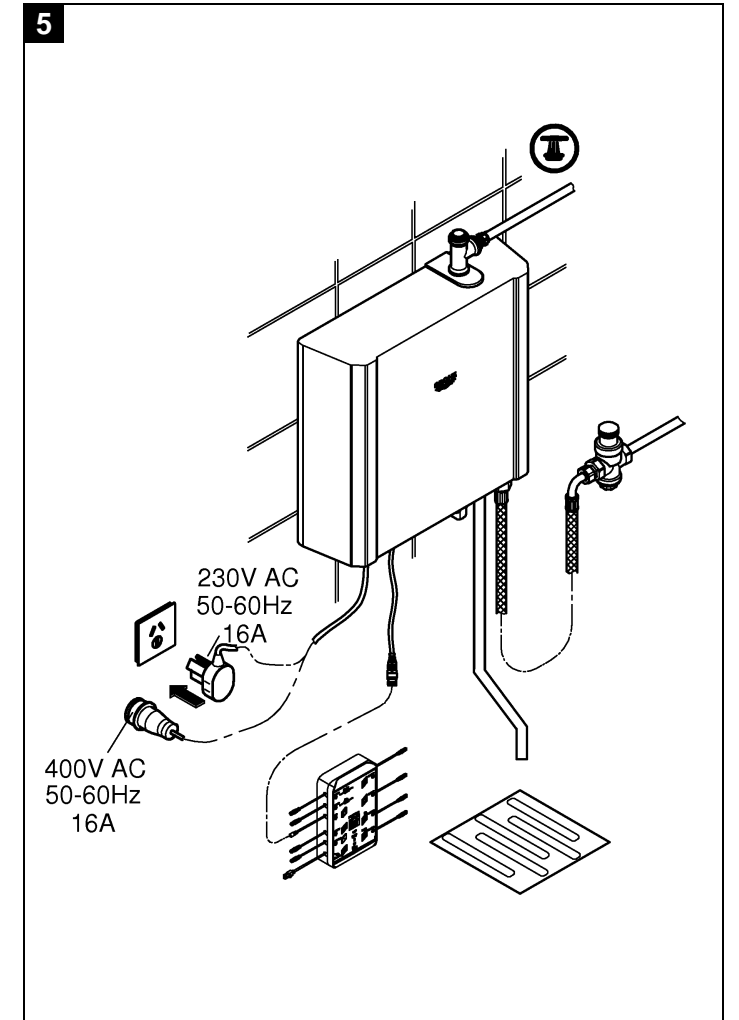
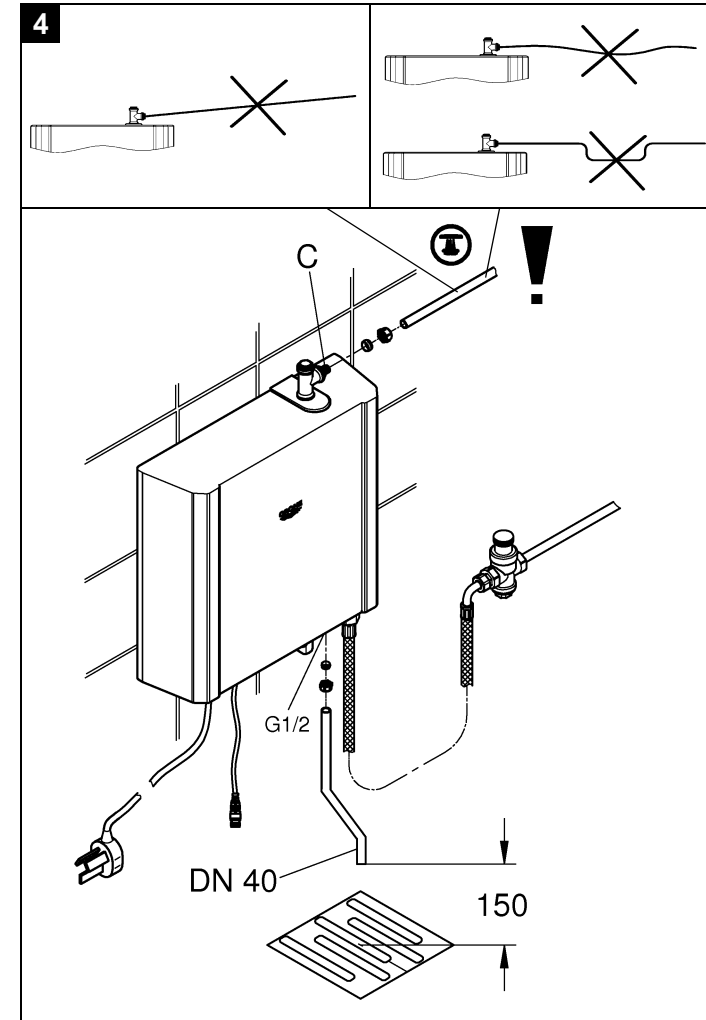
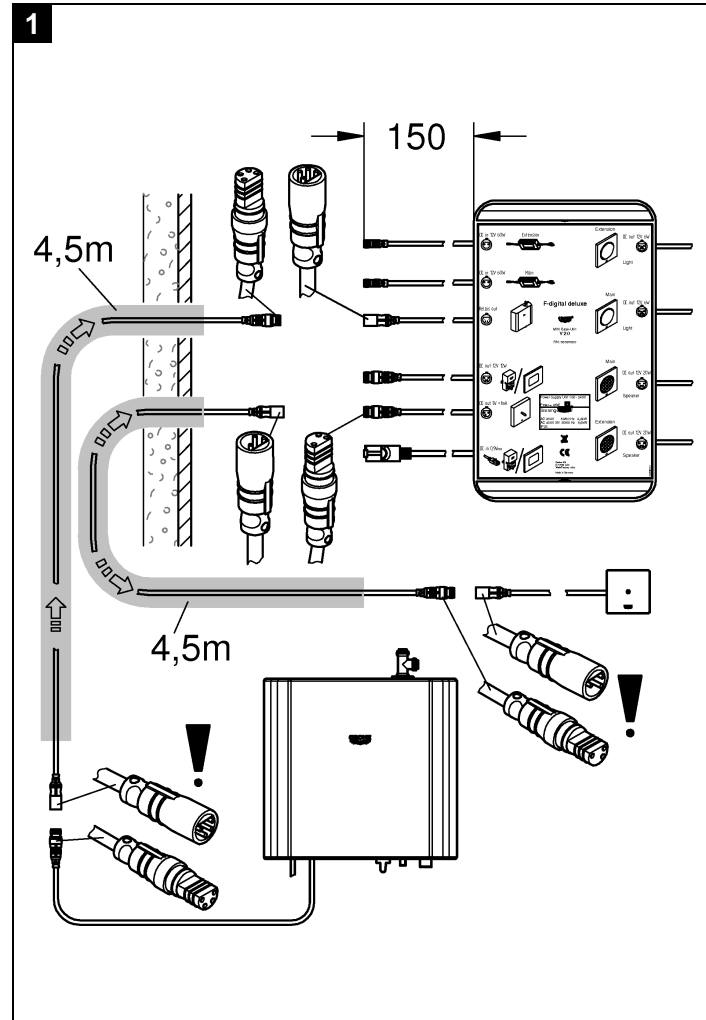
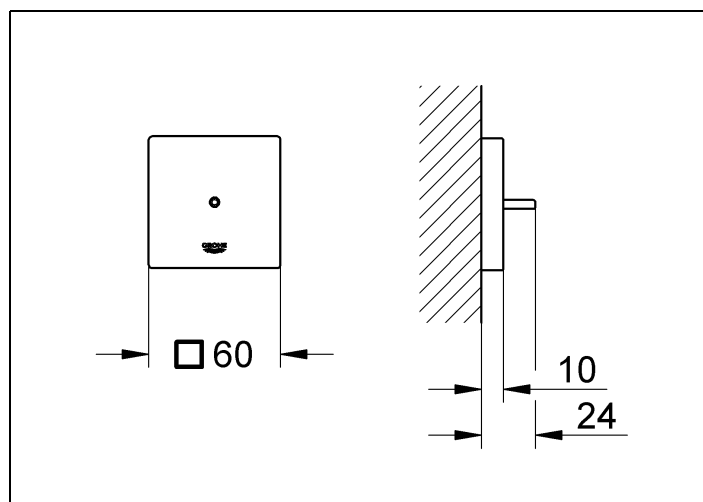
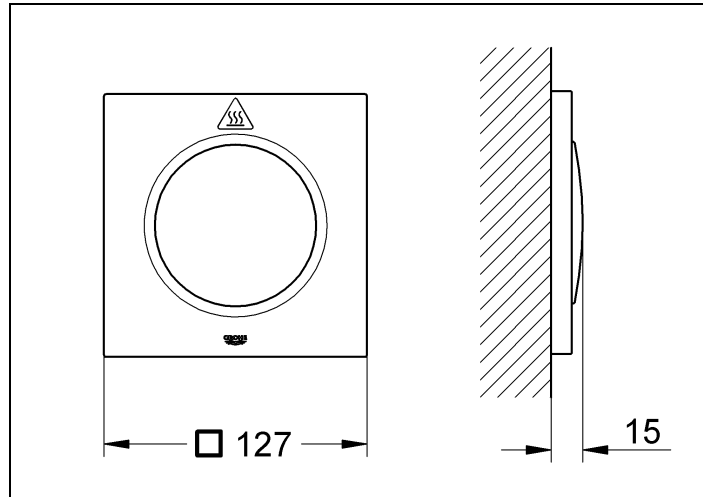
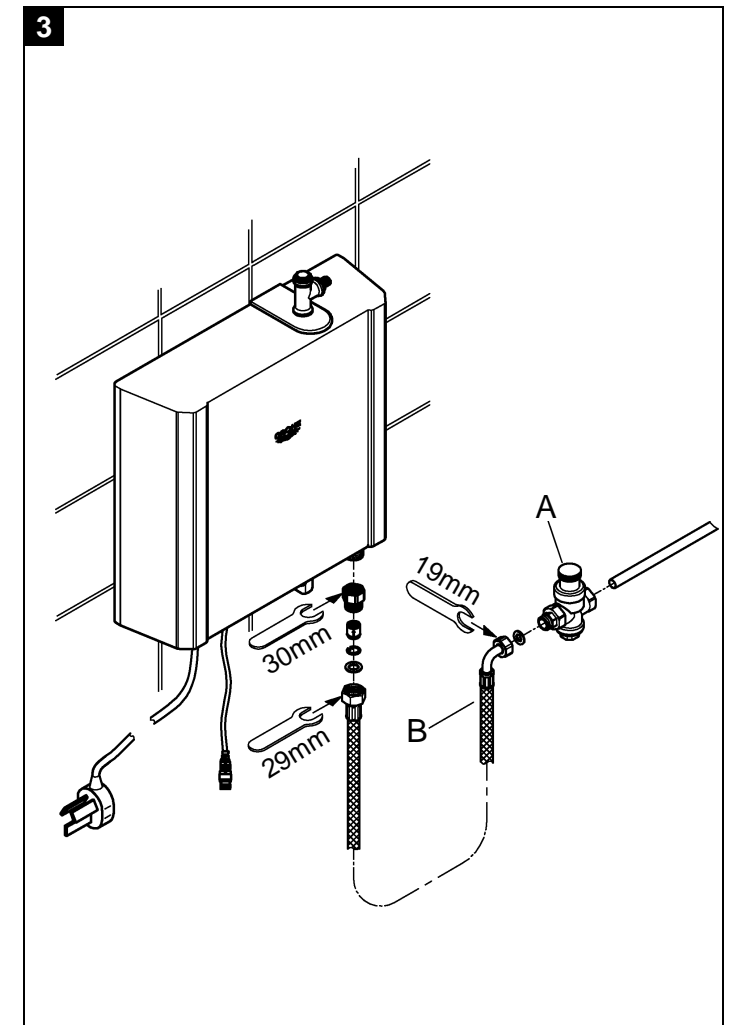
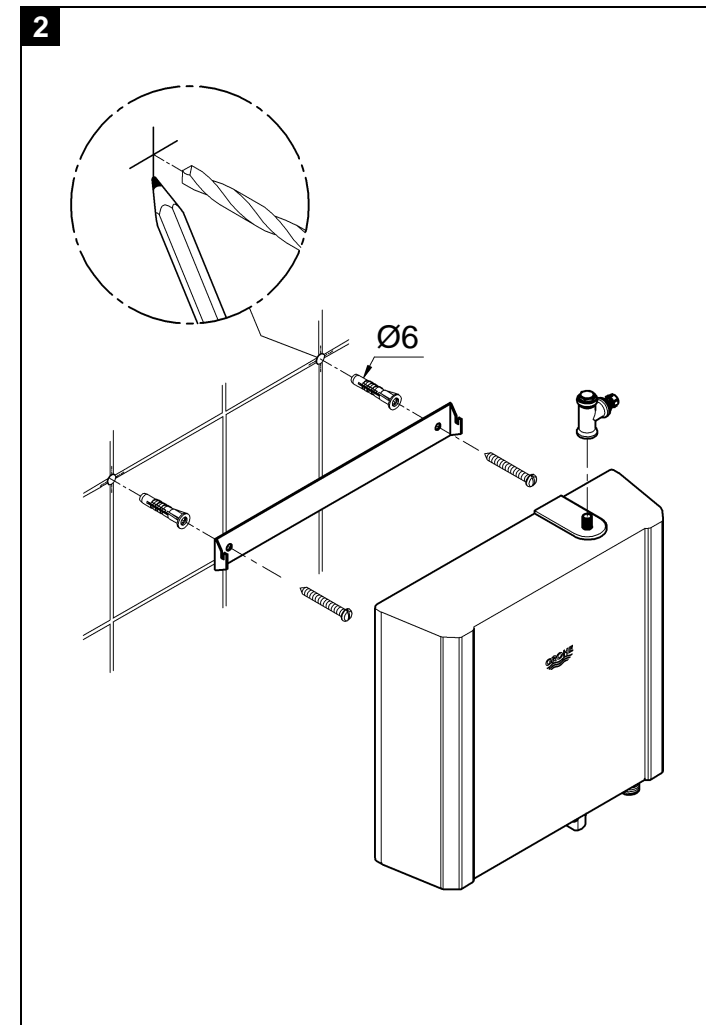
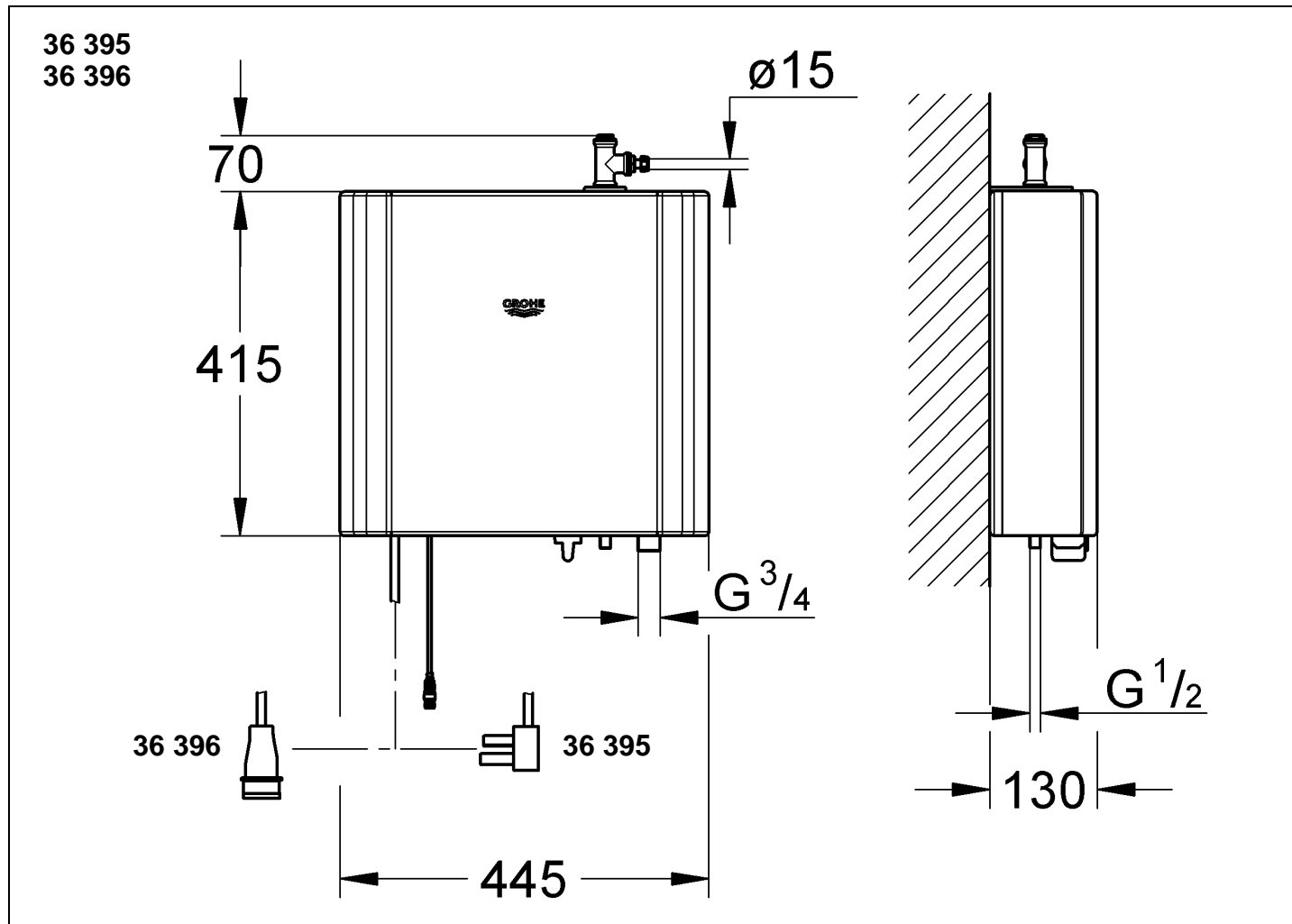

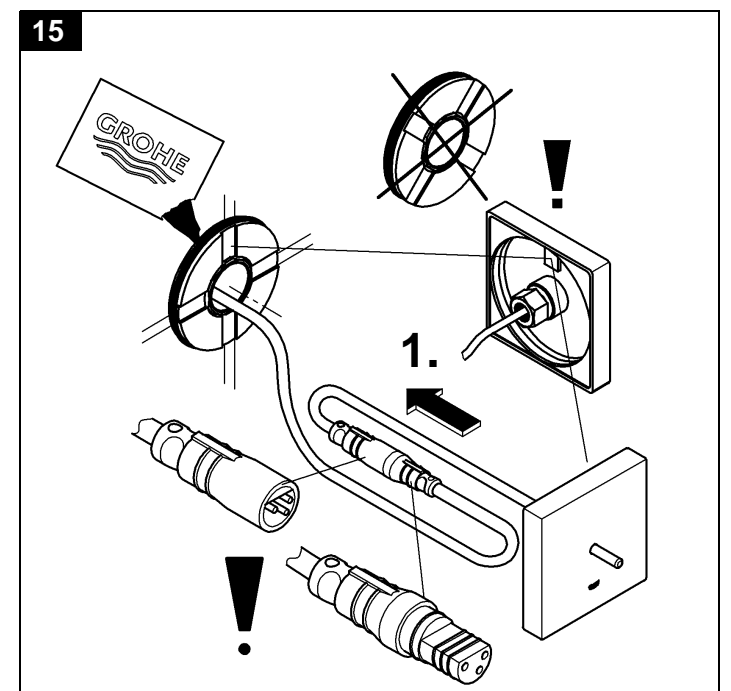
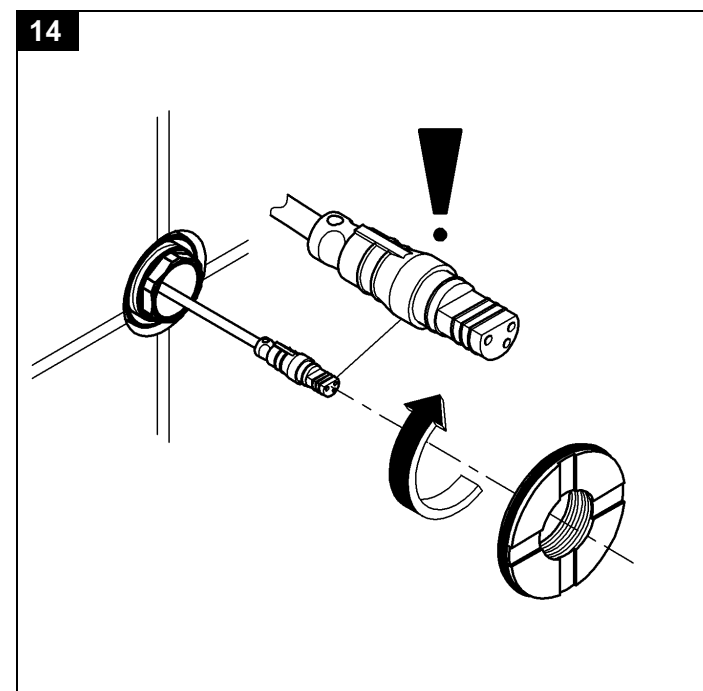
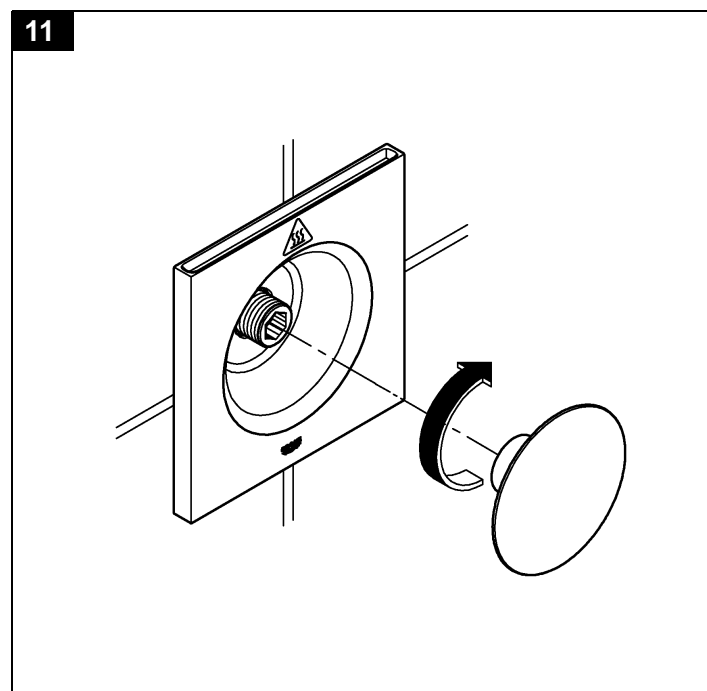
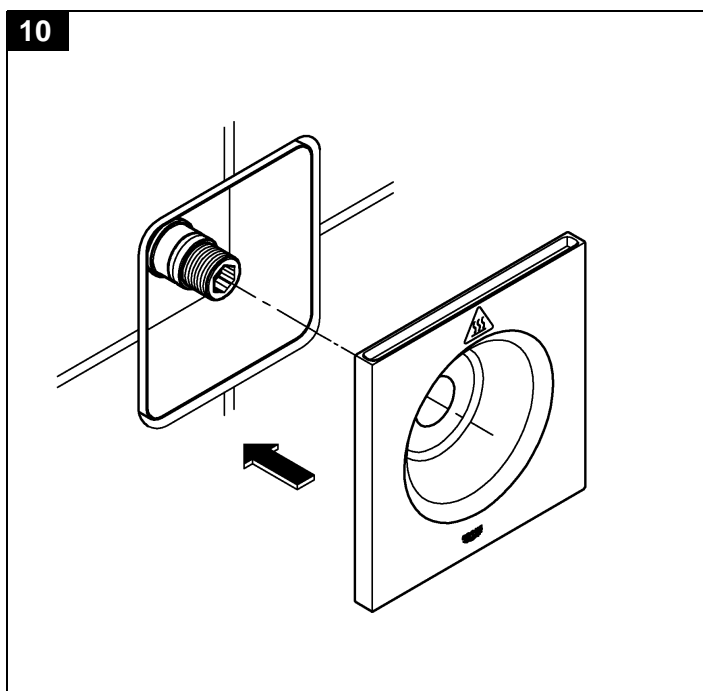
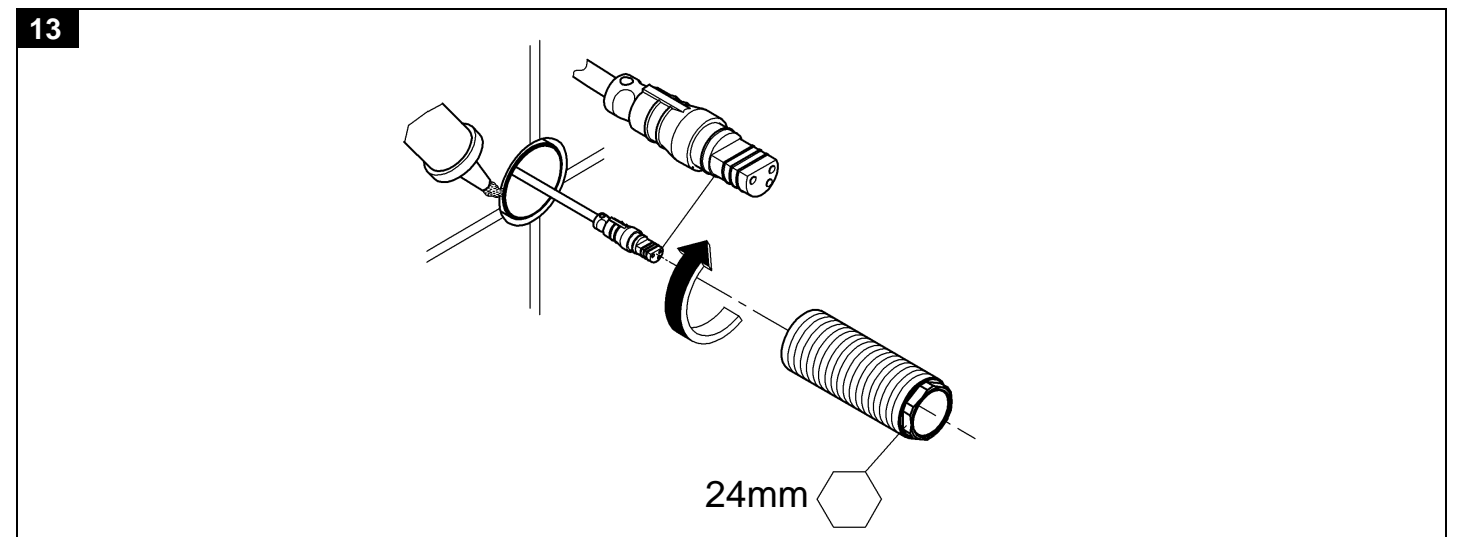
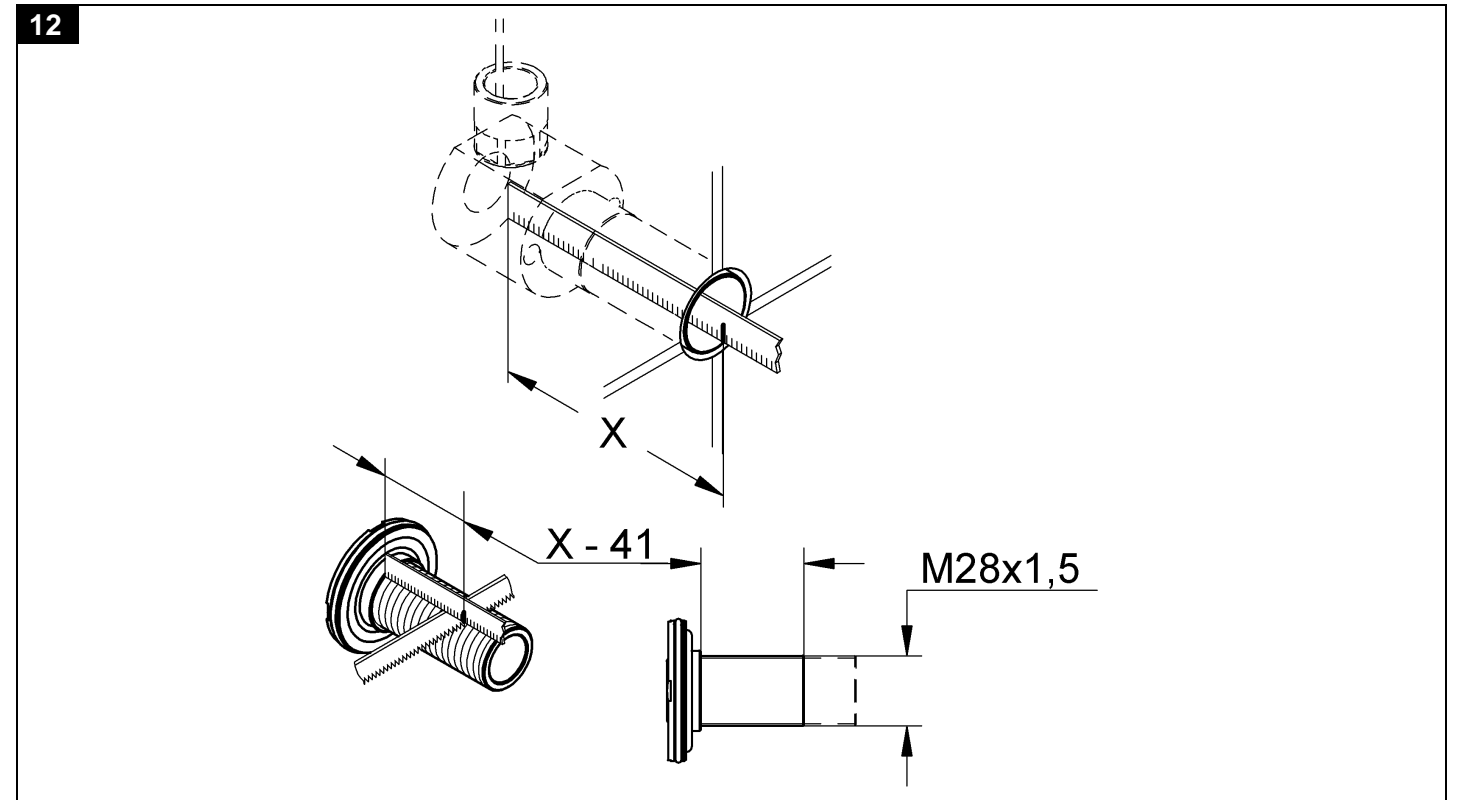
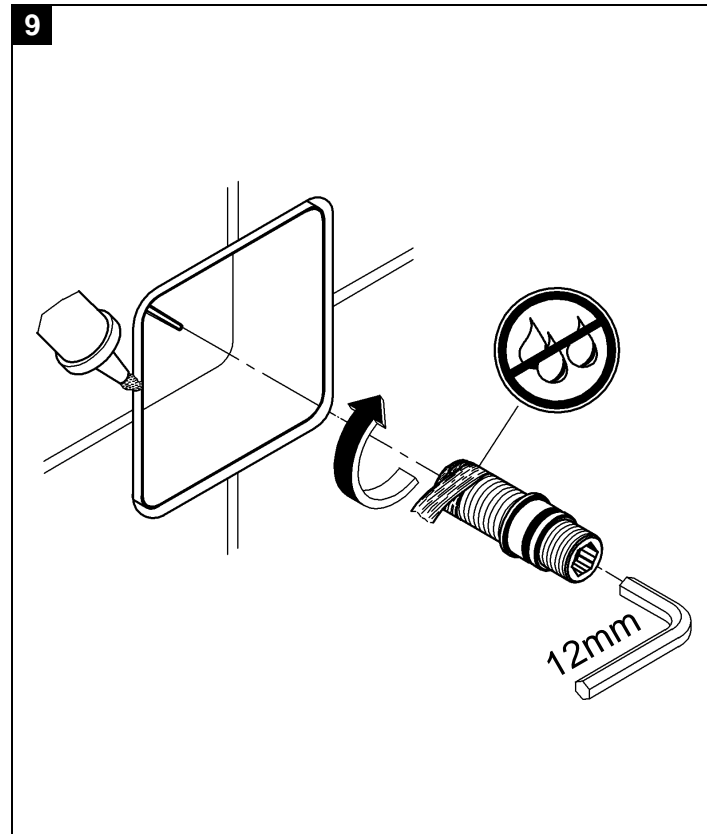
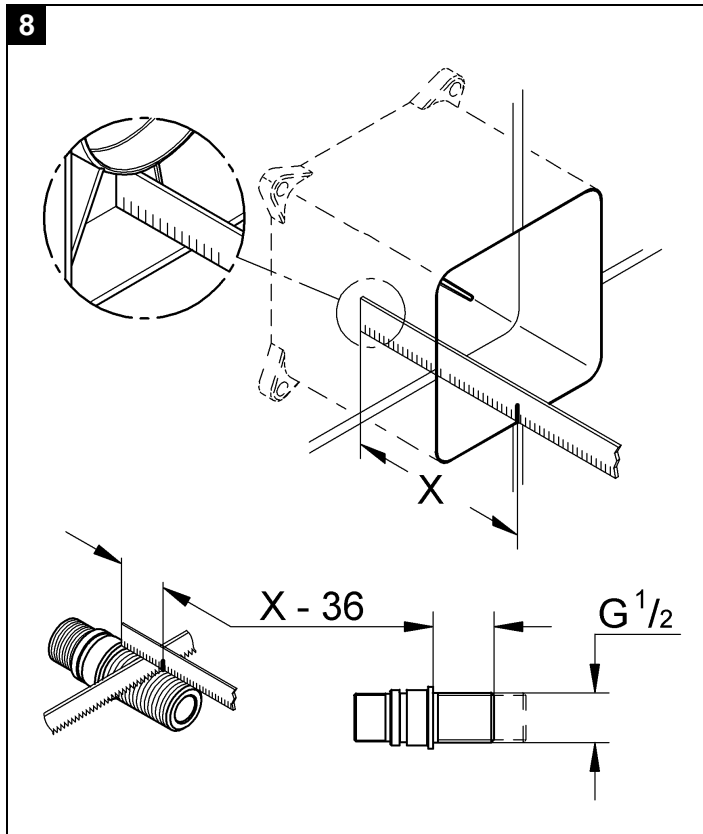
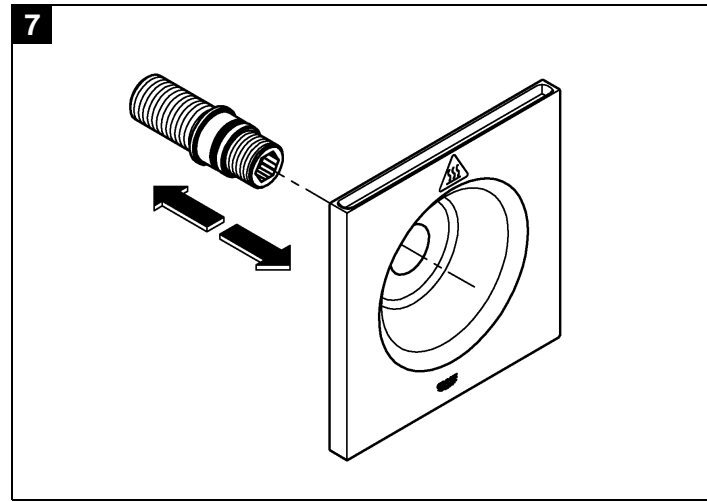
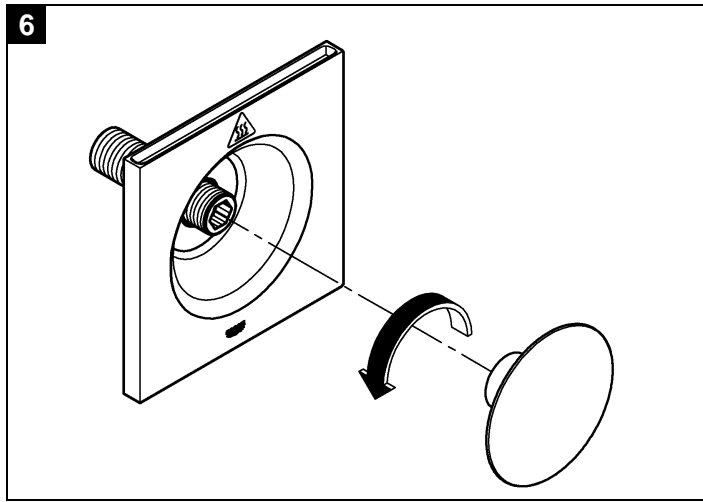



注意：在安装之前，请先阅读完整的安装指南，其中包含有关在与其他组件组合安装时的安全性和专业性的重要信息。

安全说明



产生高温。防止烫伤。



避免因连接线破损而产生危险。如果发现连接线破损，必须由制造商或其客户服务部门或具备同等资质的人员负责更换。

进行任何操作之前都需要关闭电源。

- 蒸汽生成器和连接线必须添加保护，防止接触。
- 切勿打开蒸汽生成器进行维护。
- 必须由具备相应资质的电工执行初始调试。
- 36 396 (6.6 千瓦) 的蒸汽生成器配有 3P+N+E 类型的插头 (符合 GB/T 11918 和 GB/T 11919 要求)，36 395 (2.2 千瓦) 的蒸汽生成器配有 GB 1002-2008 类型的插头。适合特定国家 / 地区的不同插头必须由具备相应资质的电工更换。请确保电流保险丝保护适合蒸汽生成器的耗电量。
- 清洁时，切勿直接或间接地用水喷洒连接器。
- 必须可以集中切换电源。
- 儿童或有身体、精神和 / 或感觉障碍的成年人不得在无人监护的情况下使用本产品。
- 受酒精或药物影响的人员不得使用本产品。

应用 / 功能

- 蒸汽生成器
- 蒸汽出口
- 热敏电阻器

技术参数

36 396

- 电源电压：400 伏 3N~ AC/50 – 60 赫兹
- 耗电量：6.6 千瓦
- 插头类型：3P+N+E，符合 GB/T 11918 和 GB/T 11919 要求

36 395

- 电源电压：230 伏 1N~ AC/50 – 60 赫兹
- 耗电量：2.2 千瓦
- 插头类型：GB 1002-2008

不同蒸汽室大小的电源要求：

蒸汽室最小 / 最大体积 (立方米)					
蒸汽生成器功率 (千瓦)	轻质墙 (钢化玻璃、Elysée/Excellent 屋等)		重墙 (瓷砖、水泥、石头等)		产汽量 (kg/hr)
	带通风装置	不带通风装置	带通风装置	不带通风装置	
2,2	-	0-2,5	-	-	3
6,6	3-9	4-最大 .12,5	2-最大 .4,5	2,5-最大 .6,5	9

- 入水口温度：最高 40 °C
- 水硬度：5° dH
- 系统压强：0.1 – 1 兆帕

电气测试参数

- 软件级别：A
 - 污染级别：1
 - 额定浪涌电压：2500 V
 - 落球冲击测试温度：100 °C
- 电磁兼容性测试 (发射干扰测试) 是以额定电压和额定电流进行的。

认证与合规性

本产品符合欧盟指令的要求：2004/108/EC 和 2006/95/EC



如需合规性声明，请向以下地址索取：
GROHE Deutschland Vertriebs GmbH
Zur Porta 9
D-32457 Porta Westfalica

重要事项！在安装之前请注意以下要求：

- 避免蒸汽管锐弯或折成直角。
- 请勿让蒸汽喷口正对墙壁、座位或其他物体。请至少与蒸汽管嘴保持 700 毫米的距离。
- 蒸汽和 / 或通风管内不得形成“积水区”。**重要事项！**不得限制蒸汽管内的流量 (通过水龙头或阀门)。不得以任何方式减少蒸汽管的内径尺寸。
- 在连续作业超过两小时的蒸汽室内，空气循环率必须达到 10-20 立方米 / 人 / 小时。
- 蒸汽生成器的电源线必须始终通电。请勿将任何开关或类似设备连接到该电缆。
- 蒸汽生成器和废水出水口之间的出水管必须始终向下倾斜。
- 蒸汽室外和蒸汽生成器周围的环境温度不得超过 35 °C。
- 斜对蒸汽出口安装热敏电阻器，并使其尽可能远离该出口 (位于 1500-1700 毫米的高度处)。
- 根据相应指南“除垢”部分的说明定期为蒸汽生成器除垢。
- 定期清洁蒸汽浴室。请参见“清洁蒸汽浴室”部分。
- **警告！**必须始终让蒸汽生成器产生的废水从蒸汽浴室外部的废水出水口流出。废水出水口必须能承受 100° C 的热水。流出的水是热水。如果水硬度超过 5° dH，必须使用水软化器。
- 从控制装置到蒸汽生成器的电缆必须使用空管 EN21，如折页 I 上的图 [1] 所示。这些空管未包含在供货规格内。
- 所有电缆必须使用牵引设备牵引，以免损坏。
- 如果空管有四处以上弯曲，必须在安装之前牵引电缆穿过空管。
- 封闭式的 5 米电缆适用于最长 4.5 米的空管。特殊配件 47 837 针对空管最长为 9.5 米的每条供应管线只能使用一次。
- 在进行维护之前，请务必断开设备的电源。
- **警告！**蒸汽出口周围的区域会有热蒸汽。

蒸汽浴室

蒸汽浴室只能使用蒸汽生成器加热。蒸汽浴室和蒸汽生成器周围的环境温度不应超过 35 °C。如果蒸汽浴室旁边有桑拿，必须是隔热的。桑拿和蒸汽浴室的墙之间必须至少留有 100 毫米的空气间隙。

蒸汽生成器

安装和连接，如折页 I 上的图 [2] 所示。

- 蒸汽生成器必须安装在足够高的位置，以便确保通向废水出水口的出水管的下斜度足够深。蒸汽生成器必须安装到提供的墙壁固定器上。

- 蒸汽生成器必须由经过授权的电工安装。蒸汽生成器连线是永久性的。生成器安装在蒸汽室外，尽量靠近控制装置（如果安装在同一层，则最远 5 米；如果安装在上一层或下一层，则最远 3 米）。
- 蒸汽生成器必须安装在干燥通风的房间内，同时废水出水口与蒸汽浴室安装在同一层，也可以安装到上一层或下一层（切勿将生成器安装到废水出水口正上方或侵蚀环境中）。

管道安装

管道必须始终由具备相应资质的安装人员安装。

进水管连接方式，参见折页 I 上的图 [3] 所示。

1. 将内径最小为 12 毫米的水管连接到减压阀 (A)，入水口最高水温为 40 °C。热水可加快加热过程。
2. 使用提供的软管 (B) 连接减压阀 (A) 和蒸汽生成器。

切勿使用旧的软管组件！

重要事项！ 在连接进水管之前，请仔细冲洗水管到蒸汽生成器之间的管路（遵循 EN 806），防止金属屑或其他异物进入蒸汽生成器管路。

蒸汽管安装，如折页 I 上的图 [4] 所示。

- 将内径最小为 12 毫米的铜管（不包含在供应条款中）连接到连接件上的蒸汽管 (C)。连接到蒸汽生成器的蒸汽管必须完全水平。

重要事项！ 蒸汽生成器和蒸汽浴室之间的管道不能包含任何“积水区”，也不能弯曲，否则蒸汽会凝结成水，如折页 I 上的图 [4] 所示。

蒸汽管应尽量不弯曲。弯曲应轻微，并且最小半径为 50 毫米。管道不得有任何明显的打结。

重要事项！ 不得限制蒸汽管内的流量（通过水龙头或阀门）。不得以任何方式减少蒸汽管的内径尺寸。所有蒸汽线路必须完全绝缘，以防止烫伤。

地板、出水口和天花板

废水出水口需要承受所有消费设备的总流量，必须安装在蒸汽浴室中。地板必须向废水出水口倾斜。合适的地板覆层包括粘合的塑料覆层、石板等。关于底层硬度、连接线等的要求与普通淋浴间相同。

如果要安装顶喷在蒸汽浴室隔间，必须确保顶喷上方的空间有足够的通风。为免损坏建筑结构，必须在所有接触面额外涂上一层防潮涂层。

警告！ 位于蒸汽管嘴下方的塑料地板和墙壁材料遇到蒸汽和热水后可能会变色。

废水出水口

蒸汽生成器中的废水出水口，如折页 I 上的图 [4] 所示。

1. 将出水管（内径最小为 12 毫米的铜管，不包含在供应条款中）连接到蒸汽生成器上的连接位置 (G $\frac{1}{2}$)。
2. 将出水管连接到蒸汽浴室外部最近的废水出水口。废水的温度大约为 95 °C。

重要事项！ 不允许关闭废水管（例如使用水龙头或类似装置）。

无论废水出口的位置在哪里，连接蒸汽生成器和废水出水口的出水管都必须向下倾斜。蒸汽生成器必须安装到提供的墙壁固定器上。

蒸汽管嘴安装，如折页 II 上的图 [6] 到 [11] 所示。

重要事项！

有关蒸汽管嘴和热敏电阻器，请阅读暗藏式固定螺母附带的产品技术信息。

蒸汽管嘴必须安装在蒸汽浴室（高度为 50 到 400 毫米），并沿纵向接到房间座位下方。请勿让蒸汽喷嘴正对墙壁、座位或其他物体。请至少与蒸汽管嘴保持 700 毫米的距离。

热敏电阻器安装，如折页 II 上的图 [12] 到 [15] 所示。

重要事项！

有关蒸汽管嘴和热敏电阻器，请阅读暗藏式固定螺母附带的产品技术信息。

电气安装



电气安装工作只能由具备相应资质的电工执行。进行此项工作时，必须遵守 IEC 364-7-701-1984 标准的规定（与 VDE 0100 第 701 部分相对应），以及所有国家、地区和当地规定。

该设备必须通过 FI 开关连接到主电源（最大释放电流 30 毫安）。蒸汽生成器的电源必须通过直接连接到主保险丝盒的插座供电，如折页 I 上的图 [5] 所示。安装后必须保证能顺利连接到插座。不应将任何开关连接到该电缆。另请参见“自动排水”部分。

确认使用的电源插座已接地！

打开主开关，检查是否有烟雾出现。

主开关

蒸汽生成器的底座上有一个“打开/关闭”开关，只能在该设备未长时间使用的情况下启动。**该设备不会在切断电源后自动排干。**

通风

如果作业时间不超过两小时，蒸汽浴室通常不要求特别通风。

出于卫生和功能方面的考虑，在连续作业超过两小时的蒸汽浴室，空气循环率必须达到 10-20 立方米/人/小时。

不得堵塞蒸汽浴室上方的任何空隙。在装有门的墙壁上钻出或凿出通风口（1000 平方毫米）以通过蒸汽浴室上方的洞通风。

进气口由靠近地板的门墙的上开口或门下的空隙组成。

出气口必须开在墙壁最顶端或天花板上，并且应尽量远离进气口。但不应位于门上方或某个座位的正上方。该出气口应连接通往外部的通气管道。可以使用现有的通气管道。该管道必须完全通气且防渗漏，并能承受较高的空气湿度。不允许出现会导致形成影响管道功能的“凝结水区”的弯曲。如果无法消除积水区，必须安装脱水器以排干凝结水。出气口必须足够大，空气排出量需达到 10-20 立方米/人/小时。

机械通风。如果空气无法自行快速流通（例如通过蒸汽浴室所处房间内的负压），必须安装换气扇。为换气扇设置的空气排出量最低须达到 10 立方米/人/小时，最高 20 立方米/人/小时。

请向本产品的用户提供这些说明！

保留进行技术修改的权利！

自动排水

该自动控制功能显著减少了水箱内碳酸钙和其他沉淀物的积聚。如果电源和蒸汽生成器之间的电缆带有开关，只能在系统关闭 110 分钟后启动，这样可让水箱自动进行排干和冲洗。因此，务必要确保电路连接故障不会导致蒸汽生成器上的自动排水功能失效。



警告！出水为热水！

除垢

定期除垢很重要，因为这样做可以延长蒸汽生成器的使用寿命并确保其正常工作。除垢是指清除墙壁上和加热组件中的钙质沉积。用户可以选择在作业时间达到 130 个小时（预设的间隔）后自动除垢，也可以选择在未满 130 小时前手动除垢。除垢时间会显示在底座控制面板上。达到指定时间后，系统会禁用蒸汽生成器。



要获得关于如何使用该应用和激活相应功能的更多说明，请到 www.grohe.com/tpif-digital-deluxe 下载。

1. 启动蒸汽生成器，并允许在容器中的水开始沸腾之后进行操作。



蒸汽出口中可能会冒出热蒸汽。

蒸汽生成器会在 20 分钟后停止。除垢的加热阶段已完成。

2. 从蒸汽生成器顶部的三通连接器拧下盖形螺母。



小心高温！防止烫伤！

3. 使用漏斗将两包 80 g 的除垢剂通过三通连接器倒入容器（产品号：14 015 000）。

4. 将盖形螺母拧回三通连接器。



大约 1,5 小时后，容器就会自动排干并冲洗干净。涂抹期间蒸汽浴室隔间不得使用。

5. 根据 Grohe SPA 应用操作指南中的说明重设除垢间隔时间。



Note: Read the complete installation instructions prior to installation. They contain important information for safe and professional installation in combination with other modules.

Safety notes



High temperatures occur. Protect against burns.



Avoid danger due to damaged connection cables. In the case of damage, the connection cable must be replaced by the manufacturer or its customer service department or an equally qualified person.

Always switch off the power supply before performing any kind of work.

- The steam generator and connections must be protected against contact.
- The steam generator must not be opened for maintenance purposes.
- **Initial commissioning** must be performed by a **qualified electrician**.
- Steam generator **36 396 (6.6 kW)** is fitted with **plug type 3P+N+E according to GB/T 11918 and GB/T 11919**, while steam generator **36 362 (2.2 kW)** is fitted with **plug type GB 1002-2008**. Different plugs for specific countries must be replaced by a **qualified electrician**. Ensure that the electrical fuse protection is suitable for the power consumption of the steam generator.
- The connectors must **not** be directly or indirectly sprayed with water when cleaning.
- It must be possible to switch the voltage supply **centrally**.
- Children or adults with physical, mental and/or sensory limitations are not permitted to use the product unsupervised.
- Persons under the influence of alcohol or drugs are not permitted to use the product.

Applications/function

- Steam generator
- Steam outlet
- Feeler gauge

Technical data

36 396

- Supply voltage: 400 V 3N⁻ AC/50 – 60Hz
- Power consumption: 6.6 kW
- Plug type: 3P+N+E according to GB/T 11918 and GB/T 11919

36 395

- Supply voltage: 230 V 1N⁻ AC/50 – 60Hz
- Power consumption: 2.2 kW
- Plug type: GB 1002-2008

Power requirements for different steam cubicle sizes:

Steam generator power in kW	Minimum/maximum volume of the steam cubicle in m ³				Steam production kg/hr
	Lightweight wall (hardened glass, Elysée/Excellent cubicle, etc.)		Heavy wall (tiles, concrete, stone, etc.)		
	with ventilation	without ventilation	with ventilation	without ventilation	
2.2	–	0–2.5	–	–	3
6.6	3–9	4–max. 12.5	2–max. 4.5	2.5–max. 6.5	9

- Water inlet: max. 40 °C
- Water hardness: 5° dH
- System pressure: 0.1 – 1 MPa

Electrical test data

- Software class: A
- Contamination class: 1
- Rated surge voltage: 2500 V
- Temperature for ball impact test: 100 °C

The test for electromagnetic compatibility (interference emission test) was performed at the rated voltage and rated current.

Approval and conformity



This product conforms to the requirements of EU guidelines: 2004/108/EC and 2006/95/EC

The conformity declarations can be obtained from the following address:

GROHE Deutschland Vertriebs GmbH

Zur Porta 9

D-32457 Porta Westfalica

IMPORTANT NOTE! Note the following prior to installation:

- Avoid sharp bends or right angles in the steam pipe.
- Do not direct the steam jet against walls, seats or other objects. Keep a minimum of 700mm away from the steam nozzle.
- "Pockets of water" must not develop in steam and/or ventilation pipes.
IMPORTANT NOTE! The flow rate inside the steam pipe must not be restricted (by a tap or valve). The inner diameter of the steam pipe must not be reduced in size in any way.
- In steambath rooms that operate continuously for more than two hours, the air must be changed at a rate of 10-20m³ per person per hour.
- The power supply cable to the steam generator must always be live. Do not connect any switches or similar devices to this cable.
- Outlet pipes between the steam generator and the waste water outlet must always be sloping downwards.
- The ambient temperature outside the vapour chamber and around the steam generator must not exceed 35 °C.
- Mount the feeler gauge diagonally as far away as possible from the steam outlet (at a height of 1500-1700mm).
- Descale the steam generator regularly according to the "Descaling" section of the instructions.
- Clean the steambath cubicle regularly. See section "Cleaning the steambath cubicle".
- **CAUTION!** The waste water from the steam generator must always be routed into a waste water outlet outside the steambath cubicle. The waste water outlet must be designed to withstand 100° C hot water. The escaping water is hot. If the water hardness exceeds 5° dH, a water softener must be used.
- Vacant tubes EN21 must be used for the cables from the control unit to the steam generator, see fold-out page I, Fig. [1]. These vacant tubes are not included in the delivery specification.
- All cables must be pulled through using a pulling device to avoid damage.
- If there are more than four bends in a vacant tube, the cables must be pulled through the tube prior to installation.
- The enclosed 5m cable is suitable for vacant tubes up to 4.5m. The special accessory 47 837 can be used once per supply line for vacant tubes up to 9.5m.
- The device must be disconnected from the power supply prior to maintenance work.
- **Caution!** Hot steam in the area around the steam outlet.

Steambath cubicle

The steambath cubicle must only be heated using the steam generator. The ambient temperature around the steambath cubicle and steam generator should not exceed 35 °C. If there is a sauna next to the steambath cubicle, it must be heat-insulated. There must be a minimum air gap of 100mm separating the walls of the sauna and the steambath cubicle.

Steam generator

Fitting and connection, see fold-out page I, Fig. [2].

- The steam generator **must** be installed in a position high enough to ensure that the downward gradient of the outlet pipe leading to the waste water outlet is sufficiently steep. The steam generator must be mounted on the wall holders provided.

- The steam generator **must** be installed by an **authorised electrician**.

The steam generator connections are permanent. The generator is installed outside the steam cubicle as close as possible to the control unit (a maximum of 5m away on the same floor or a maximum of 3m away on the floor above or below).

- The steam generator **must** be installed in a dry and ventilated room with a waste water outlet on the same floor as the steambath cubicle or one floor above or below. (Never install the generator directly above a waste water outlet or in an aggressive environment).

Pipe installation

The pipes **must always** be installed by a **qualified installer**.

Water connection, see fold-out page I, Fig. [3].

1. Connect a water line with a minimum internal diameter of 12mm to the pressure-reducing valve (A) and with a maximum water temperature at the inlet of 40 °C. Warm water accelerates the heating process.
2. Establish a connection between the pressure-reducing valve (A) and steam generator using the hose provided (B).

Never reuse old hose sets!

IMPORTANT NOTE! Before connecting the water supply, carefully flush out the pipes to the steam generator (observe EN 806) to prevent metal chips or other foreign bodies from entering the steam generator lines.

Steam pipe installation, see fold-out page I, Fig. [4].

- Connect a copper pipe with a minimum inner diameter of 12mm (not included in the delivery specification) to steam outlet (C) on the connecting piece. The steam pipe leading to the steam generator must be perfectly horizontal.

IMPORTANT NOTE! The pipes between the steam generator and the steambath cubicle must not contain any "pockets of water" or bends where steam can condense and accumulate as water, see fold-out page I, Fig. [4].

The steam pipe should have as few bends as possible. The bends should curve gently and have a minimum radius of 50mm. The pipes must not contain any sharp kinks.

IMPORTANT NOTE! The flow rate inside the steam pipe must not be restricted (by a tap or valve). The inner diameter of the steam pipe must not be reduced in size in any way.

All steam lines must be insulated from end to end to protect against burns.

Floor, waste water outlet and ceiling

A waste water outlet designed to withstand the total flow rate of the consumer devices must be installed in the steambath cubicle. The floor must slope towards the waste water outlet. Suitable floor coverings include bonded plastic coverings, stone slabs, etc. The requirements for the consistency of the substrate, connections, etc. are the same as those of a shower cubicle. **If a ceiling shower is to be installed in the steam bath cubicle, sufficient ventilation must be provided for the space above the ceiling shower. To avoid damage to the building structure, an additional coat of moisture-proof finish must be applied to all surfaces.**

CAUTION! Plastic floor and wall materials located under the steam nozzle may change colour after coming into contact with steam and hot water.

Waste water outlet

Waste water outlet from steam generator, see fold-out page I, Fig. [4].

1. Connect the outlet pipe (copper pipe with a minimum inner diameter of 12mm, not included in the delivery specification) to the connection (G½") on the steam generator.
2. Route the outlet pipe to the nearest waste water outlet outside the steambath cubicle. The temperature of the waste water is approx. 95 °C.

IMPORTANT NOTE! Shutting off the waste water pipe (e.g. with a tap or similar) is not permitted.

The outlet pipe from the steam generator to the waste water outlet must slope downwards regardless of the position of the waste water opening. The steam generator must be mounted on the wall holders provided.

Steam nozzle installation, see fold-out page II, Fig. [6] to [11].

IMPORTANT NOTE!

Read the technical product information provided with the concealed mounting sets for the steam nozzle and feeler gauge.

The steam nozzle must be installed in the steambath cubicle at a height of 50 to 400mm and routed underneath the seats in the room in a longitudinal direction. Do not direct the steam jet against walls, seats or other objects. Keep a minimum of 700mm away from the steam nozzle.

Feeler gauge installation, see feeler gauge II, Fig. [12] to [15].

IMPORTANT NOTE!

Read the technical product information provided with the concealed mounting sets for the steam nozzle and feeler gauge.

Electrical installation



Electrical installation work must only be performed by a qualified electrician. This work must be carried out in accordance with the regulations according to IEC 364-7-701-1984 (corresponding to VDE 0100 Part 701) as well as all national and local regulations.

The device must be connected to the mains power supply via an FI switch (maximum release current 30 mA). The power supply for the steam generator must be established via a socket connected directly to the mains fuse box, see fold-out page I, Fig. [5]. Unobstructed access to the socket must be guaranteed after installation. No switches should be connected to this cable. See also section "Automatic drainage".

Check that the electrical socket used is earthed!

Switch on the main switch and check whether smoke emerges.

Main switch

There is an on/off switch at the base of the steam generator that should only be actuated if the device has not been used for a long time. **The device is not drained automatically when disconnected from the power supply!**

Ventilation

Steambath cubicles do not generally require special ventilation if operated for less than two hours.

In steambath rooms that operate continuously for more than two hours, the air must be changed at a rate of 10-20m³ per person per hour for hygiene and functional reasons.

Any clear space above the steambath cubicle must not be closed off. Drill or cut a ventilation opening (1000mm²) into the wall where the door is located to ventilate the cavity above the steambath cubicle.

The air inlet consists of an opening in the door wall near to the floor or a gap under the door.

The air outlet must be integrated at the very top of the wall or in the ceiling and should be positioned as far away from the air inlet as possible. However, it should not be positioned above the door or directly above one of the seats. The outlet is connected to an air duct that leads outside.

An existing air duct can be used. The duct must be completely steam and watertight and designed to withstand the high degree of moisture in the air. Bends that allow the formation of "pockets of condensate" which affect the function of the duct are not permitted. If pockets of water are unavoidable, a water separator must be installed to drain the condensate. The air outlet must be large enough to discharge 10-20m³ of air per person per hour.

Mechanical ventilation. If the air does not escape quickly enough by itself, e.g. through negative pressure in the room where the steambath cubicle is located, a ventilator must be installed. The fan must be set to extract a minimum of 10m³ and a maximum of 20m³ of air per person per hour.

Automatic drainage

This automatic control considerably reduces the accumulation of calcium carbonate and other deposits in the water tank. If there is a switch in the cable between the power supply and the steam generator, it can only be actuated 110 minutes after the system is switched off so that the water tank can drain and flush automatically. It is therefore important that a faulty electrical connection does not render inoperative the automatic drainage function on the steam generator.



WARNING! The water is hot!

Descaling

Regular descaling is important because it extends the service life of the steam generator and ensures that it functions correctly. Descaling removes limescale deposits from walls and heating elements. The user has the option of descaling automatically after 130 hours of operation (preset interval) or descaling manually before the 130 hours elapse. The descaling time is displayed on the docking station control panel. The steam generator is disabled when the time elapses.



Additional instructions on how to use the app and activate the functions can be downloaded at www.grohe.com/tpif-digital-deluxe.

1. Start the steam generator and allow to operate until the water in the container starts to boil.



Hot steam may escape from the steam outlet.

The steam generator stops after 20 minutes. The heating phase for descaling is complete.

2. Unscrew the cap nut from the three-way coupling at the top of the steam generator.



Caution hot! Protect against burns!

3. Pour two 80g packs of descaling agent into the container via the three-way coupling using a funnel (Prod no.: 14 015 000).

4. Screw the cap nut back onto the three-way coupling.



After approx. 1,5 hours, the container is drained and flushed clean automatically. **The steambath cubicle must not be used during this time period.**

5. Reset the timer for the descaling interval as described in the Grohe SPA app operating instructions.



A series of 25 horizontal lines for writing, evenly spaced and extending across the width of the page.

Pure Freude an Wasser



D
☎ +49 571 3989 333
impressum@grohe.de

A
☎ +43 1 68060
info-at@grohe.com

AUS
Argent Sydney
☎ +(02) 8394 5800
Argent Melbourne
☎ +(03) 9682 1231

B
☎ +32 16 230660
info.be@grohe.com

BG
☎ 0800 770 1222
falecom@grohe.com

BR
☎ +359 2 9719959
grohe-bulgaria@grohe.com

CAU
☎ +99 412 497 09 74
info-az@grohe.com

CDN
☎ +1 888 6447643
info@grohe.ca

CH
☎ +41 448777300
info@grohe.ch

CN
☎ +86 21 63758878

CY
☎ +357 22 465200
info@grome.com

CZ
☎ +420 277 004 190
grohe-cz@grohe.com

DK
☎ +45 44 656800
grohe@grohe.dk

E
☎ +34 93 3368850
grohe@grohe.es

EST
☎ +372 6616354
grohe@grohe.ee

F
☎ +33 1 49972900
marketing-fr@grohe.com

FIN
☎ +358 10 8201100
teknocalor@teknocalor.fi

GB
☎ +44 871 200 3414
info-uk@grohe.com

GR
☎ +30 210 2712908
nsapountzis@ath.forthnet.gr

H
☎ +36 1 2388045
info-hu@grohe.com

HK
☎ +852 2969 7067
info@grohe.hk

I
☎ +39 2 959401
info-it@grohe.com

IND
☎ +91 124 4933000
customercare.in@grohe.com

IS
☎ +354 515 4000
jonst@byko.is

J
☎ +81 3 32989730
info@grohe.co.jp

KZ
☎ +7 727 311 07 39
info-cac@grohe.com

LT
☎ +372 6616354
grohe@grohe.ee

LV
☎ +372 6616354
grohe@grohe.ee

MAL
☎ +1 800 80 6570
info-singapore@grohe.com

MX
☎ 01800 8391200
pregunta@grohe.com

N
☎ +47 22 072070
grohe@grohe.no

NL
☎ +31 79 3680133
vragen-nl@grohe.com

NZ
☎ +09/373 4324

P
☎ +351 234 529620
commercial-pt@grohe.com

PL
☎ +48 22 5432640
biuro@grohe.com.pl

RI
☎ +62 21 2358 4751
info-singapore@grohe.com

RO
☎ +40 21 2125050
info-ro@grohe.com

ROK
☎ +82 2 559 0790
info-singapore@grohe.com

RP
☎ +63 2 8041617

RUS
☎ +7 495 9819510
info@grohe.ru

S
☎ +46 771 141314
grohe@grohe.se

SGP
☎ +65 6 7385585
info-singapore@grohe.com

SK
☎ +420 277 004 190
grohe-cz@grohe.com

T
☎ +66 2610 3685
info-singapore@grohe.com

TR
☎ +90 216 441 23 70
GroheTurkey@grome.com

UA
☎ +38 44 5375273
info-ua@grohe.com

USA
☎ +1 800 4447643
us-customerservice@grohe.com

VN
☎ +84 8 5413 6840
info-singapore@grohe.com

AL **BiH** **HR** **KS**
ME **MK** **SLO** **SRB**
☎ +385 1 2911470
adria-hr@grohe.com

**Eastern Mediterranean,
Middle East - Africa
Area Sales Office:**
☎ +357 22 465200
info@grome.com

IR **OM** **UAE** **YEM**
☎ +971 4 3318070
grohedubai@grome.com

Far East Area Sales Office:
☎ +65 6311 3600
info@grohe.com.sg

Latin America:
☎ +52 818 3050626
pregunta@grohe.com

www.grohe.com

2016/09/28