

PRECISION FEEL
DESIGN + ENGINEERING
GROHE GERMANY

99.0286.031/ÄM 231447/10.14

www.grohe.com

Pure Freude an Wasser



34 538

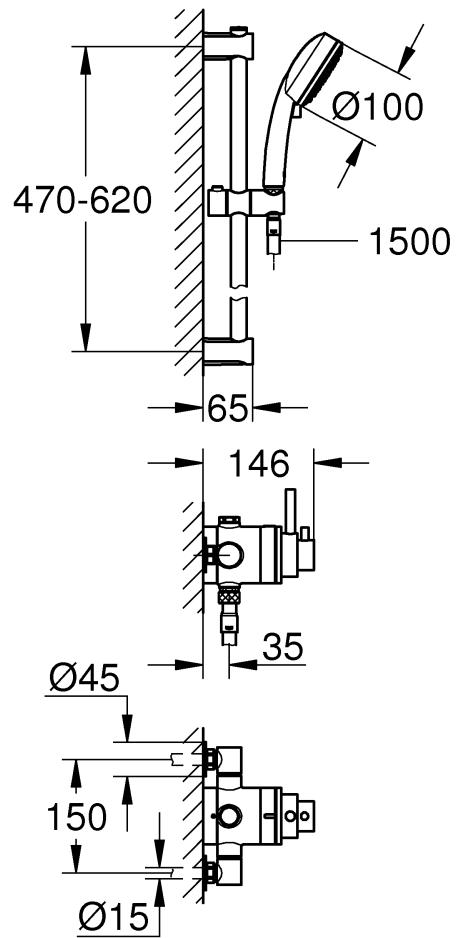
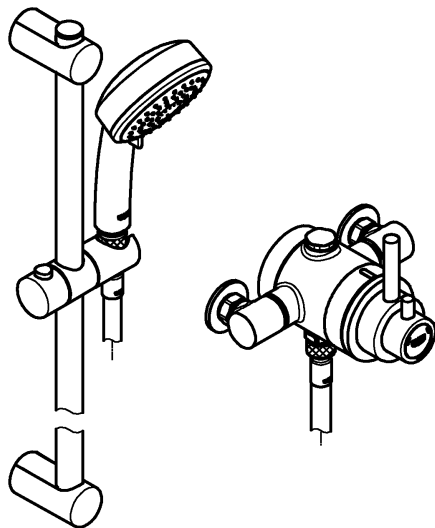

.....1



.....4



...5-6



.....8



....2-3



.....4



.....7



.....9

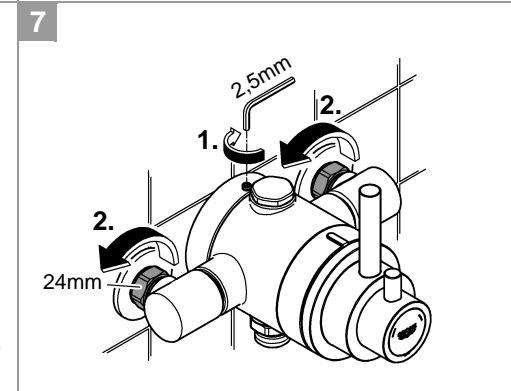
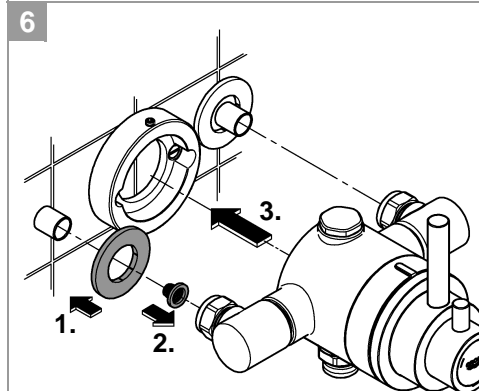
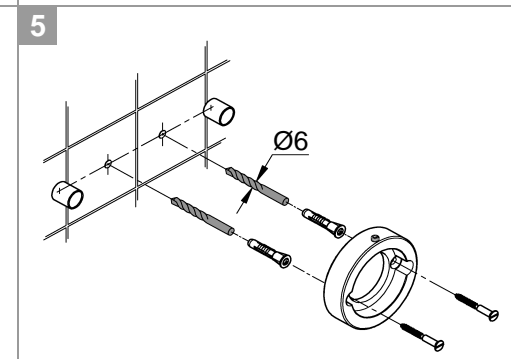
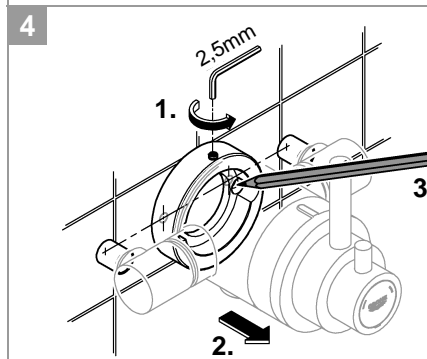
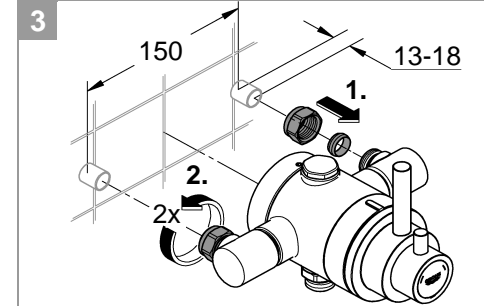
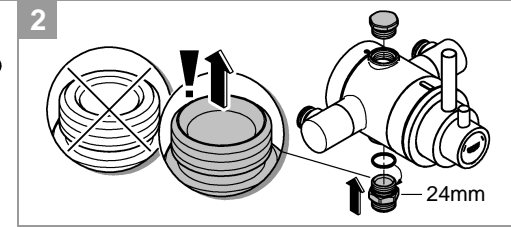
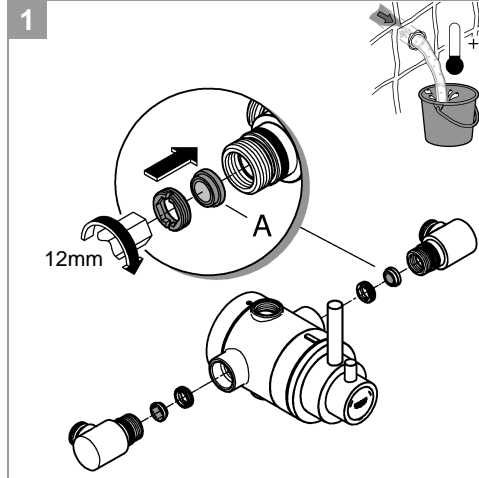
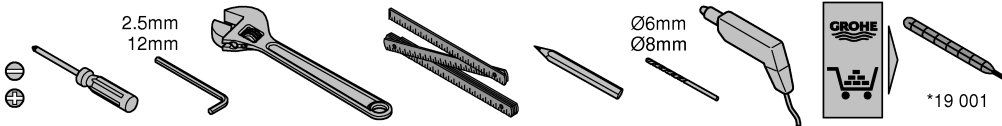
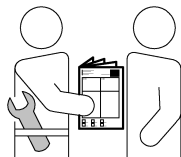
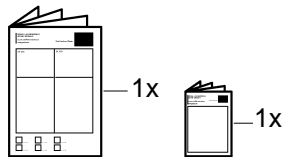
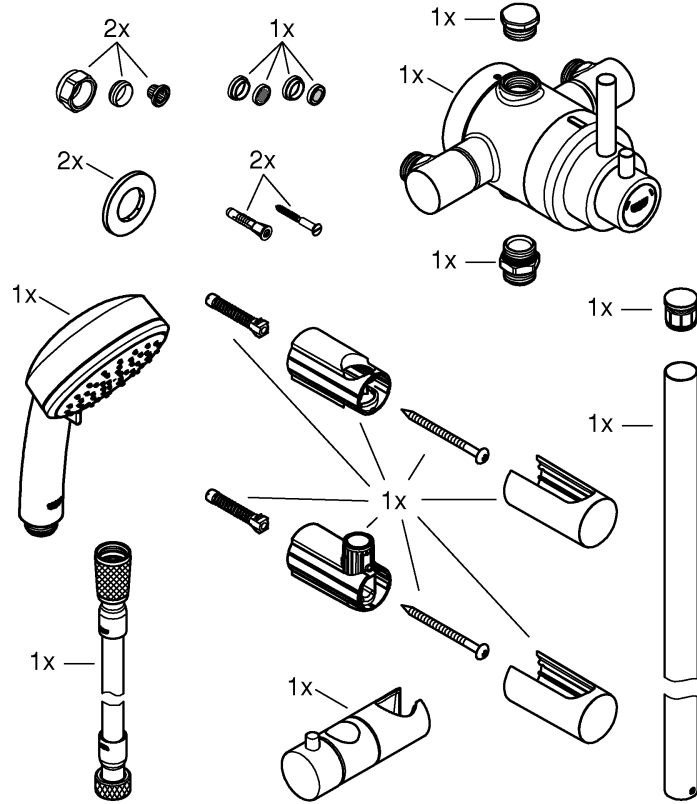

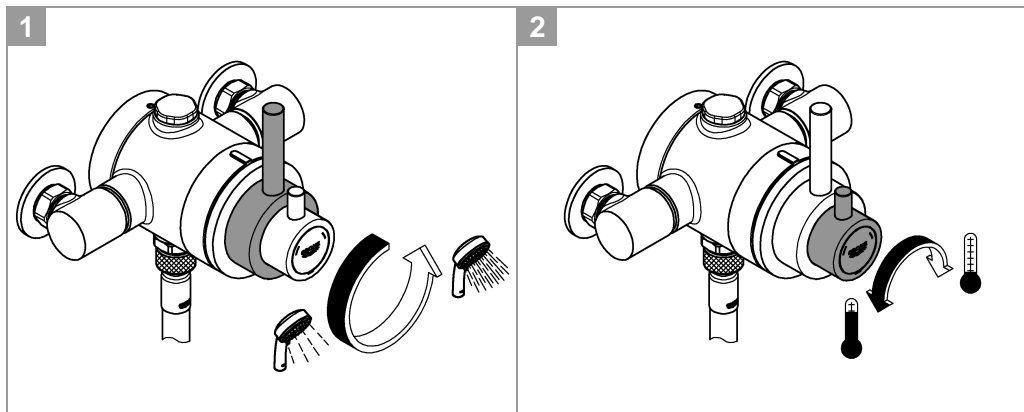
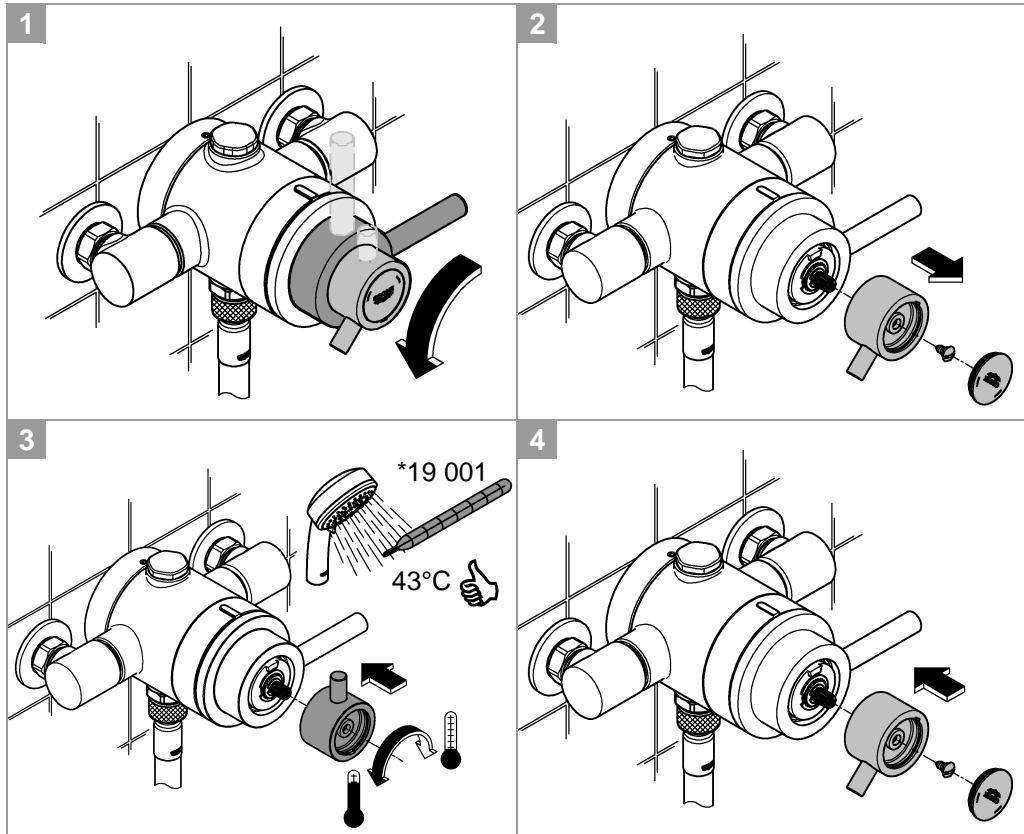
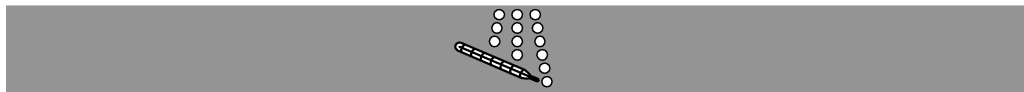
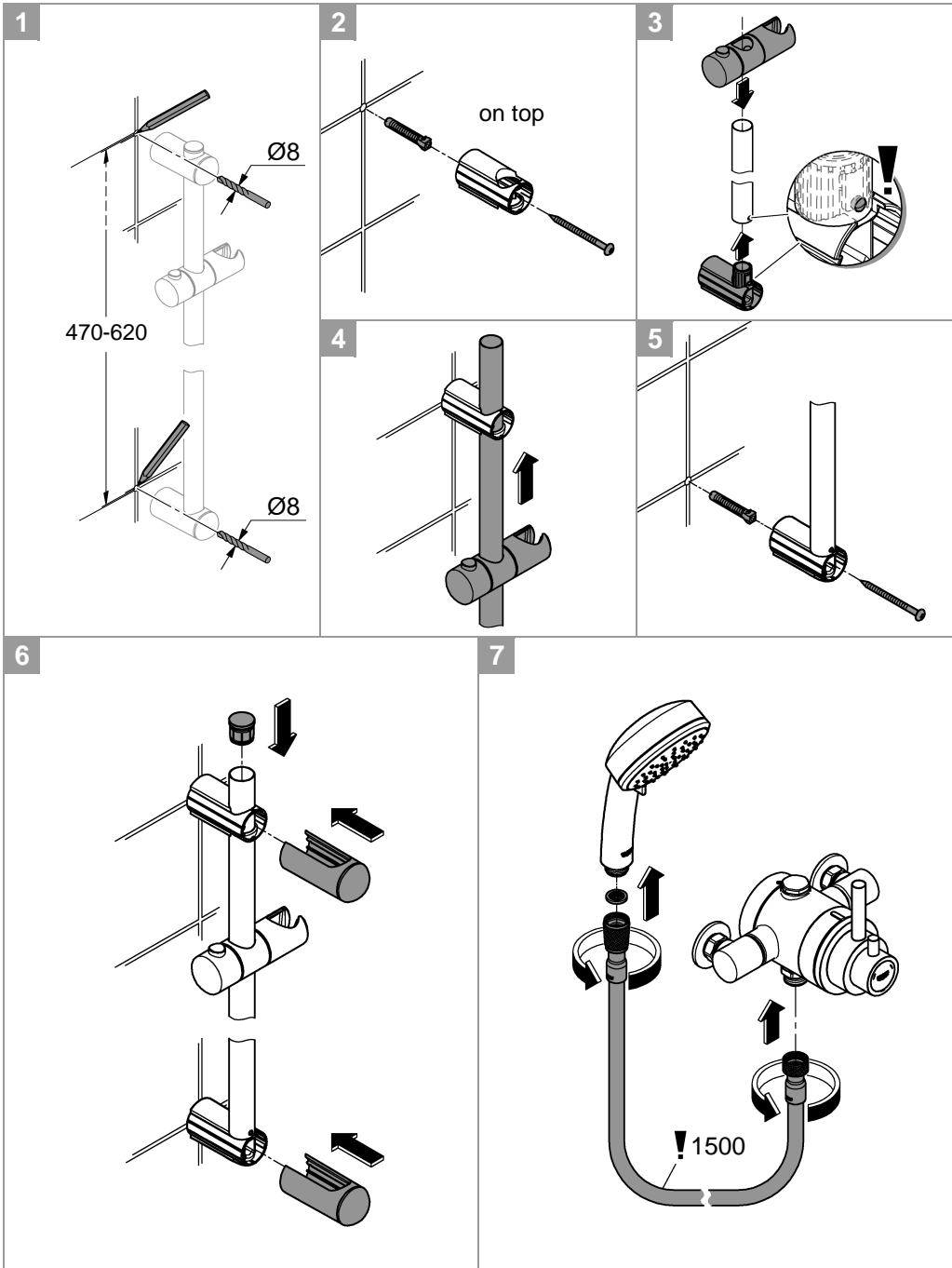



Safety and important information

This thermostatic valve will suit supplies of:
Low pressure shower (LP-S).

Conditions of use TMV2

	High pressure	Low pressure
Max. static pressure	10bar	10bar
Flow pressure hot & cold	0.5 to 5bar	0.1 to 1bar
Hot supply temperature	55 to 65°C	55 to 65°C
Cold supply temperature	equal to or less than 25°C	equal to or less than 25°C

NOTE: Valves operating outside these conditions cannot be guaranteed by the Scheme to operate as Type 2 valves.

If a water supply is fed by gravity then the supply pressure should be verified to ensure the conditions of use are appropriate for the valve.

Recommended outlet temperature

- 44 °C for bath fill
- but:
- 41 °C for shower and washbasin
 - 38 °C for bidet

The mixed water temperatures must never exceed 46°C.

The maximum mixed water temperature can be 2°C above the recommended maximum set outlet temperatures.

NOTE: 46°C is the maximum mixed water temperature from the bath tap. The maximum temperature takes account of the allowable temperature tolerances inherent in thermostatic mixing valves and temperature losses in metal baths.

It is not a safe bathing temperature for adults or children.

The British Burns Association recommends 37 to 37.5°C as a comfortable bathing temperature for children. In premises covered by the Care Standards Act 2000, the maximum mixed water outlet temperature is 43°C.

The thermostatic mixing valve will be installed in such a position that maintenance of the TMV and its valves and the commissioning and testing of the TMV can be undertaken.

Requirements shall be verified against the original set temperature results once a year.

The installation of thermostatic mixing valves must comply with the requirements of the Water Supply (Water Fittings) Regulations 1999.

The fitting of isolation valves is required as close as is practicable to the water supply inlets of the thermostatic mixing valve.

Notes

If there is a residual flow during the commissioning or the annual verification (cold water supply isolation test), then this is acceptable providing the temperature of the water seeping from the valve is no more than 2°C above the designated maximum mixed water outlet temperature setting of the valve.

Application

Thermostat mixers are designed for hot water supply via pressurised storage heaters and, utilised in this way, provide the best temperature accuracy. With sufficient power output (from 18 kW or 250 kcal/min), electric or gas instantaneous heaters are also suitable.

Thermostats **cannot** be used in conjunction with non-pressurised storage heaters (displacement water heaters).

All thermostats are adjusted in the factory at a flow pressure of 0.6:0.6 bar on both sides.

Should temperature deviations occur on account of special installation conditions, the thermostat must be adapted to local conditions (see Adjusting).

Specifications

Test pressure	16 bar
Mixed water flow rate without downstream resistance:	
0,1 bar	approx. 7,5 l/min
0,2 bar	approx. 10,5 l/min
0,3 bar	approx. 14 l/min
0,4 bar	approx. 17 l/min
0,5 bar	approx. 18,5 l/min
0,6 bar	approx. 21 l/min
Max. water temperature at hot water supply	70 °C
Cold water connection	right
Hot water connection	left
Minimum flow rate	= 5 l/min

If static pressure is not in necessary level , a pressure reducing valve must be fitted.



Installation, see page 2 and 3.

Flush piping system prior and after installation of fitting thoroughly (Consider EN 806)!

If there is a pressure difference between the hot and cold water supply install attached flow limiters (A) in the water connection elbows, see page 2, Fig. 1 and table below.

Cold Water Inlet	Warm Water Inlet	Connection	
		Cold	Warm
0.1 - 1 bar	0.1 - 1 bar	without	without
1 - 5 bar	1 - 5 bar	7 l (green)	5 l (yellow)
1.5 - 10 bar	0.1 - 0.5 bar	7 l (green)	without
	> 0.5 bar	7 l (green)	5 l (yellow)

Screw-mount the mixer and test the connections for **water tightness**.



Adjusting, see page 3.

Open the shut-off valve and turn temperature lever counter-clockwise to maximum hot water temperature. Check the temperature of the water with a thermometer. If temperature is not 43°C an adjustment is necessary. Turn regulating nut until the water temperature has reached 43 °C.



Operation, see page 4.

Prevention of frost damage

When the domestic water system is drained, thermostats must be drained separately, since non-return valves are installed in the hot and cold water connections. For this purpose, the mixer must be removed from the wall.



Maintenance, see page 7.

Shut off hot and cold water supplies.

I. Control unit

Remove control unit, see page 7, Figs. [1] - [4].

Inspect and clean all parts, replace if necessary and lubricate with special grease.

Reinstall control unit, see Figs. [5] - [9].

- Reinstall O-ring and screw in control unit, see Fig. [5].
- Push on adapter and shut-off lever.
- Turn the lever clockwise to the close position
- Pull off lever and adapter again, see Fig. [6].
- Reinstall wax element, slider and spring from behind, see Fig. [7].
- Unscrew seat 1/8 to 1/6 turn (45° to 60°), see Fig. [8].
- Reinstall valve, see Fig. [9].

II. Non-return valve, see pages 2 and 7.

- Remove valve from the supplies, see page 7, Fig. [2].
- Unscrew elbow and remove threaded ring with flow limiter (A) if installed, see page 2, Fig. [1].
- Take out and clean or replace non-return valve, see page 7, Fig. [10].

Install in reverse order.

Readjustment is necessary after every maintenance (see Adjusting).



Replacement parts, see page 8

(* = special accessories).

Care

For directions on the care of this fitting, please refer to the accompanying Care Instructions.

Trouble Shooting

Problem	Cause	Remedy
Thermostatic valve opens through hot	Hot and cold water supplies have been connected in reverse	Rotate the thermostatic mixing valve
Range of temperature adjustment restricted	High pressure difference between hot and cold water supply	Install flow limiter see chapter Exposed Installation
Shower insufficiently cold or hot	Adjustment incorrectly set Hot water supply temperature too low	Refer to the instructions in chapter Adjustment Check hot water source temperature setting
No flow of hot or cold water	Either the hot or cold side is not fully pressurized Debris caught inside the inlet of the control unit	Replace non-return valve, refer to chapter Maintenance Remove mixing valve and flush out or remove any debris lodged inside the hot or cold inlets or filters
Hot water emerges to cold water supply or vice versa	Non return valves are damaged in cause of lime	Replace non-return valve, refer to chapter Maintenance

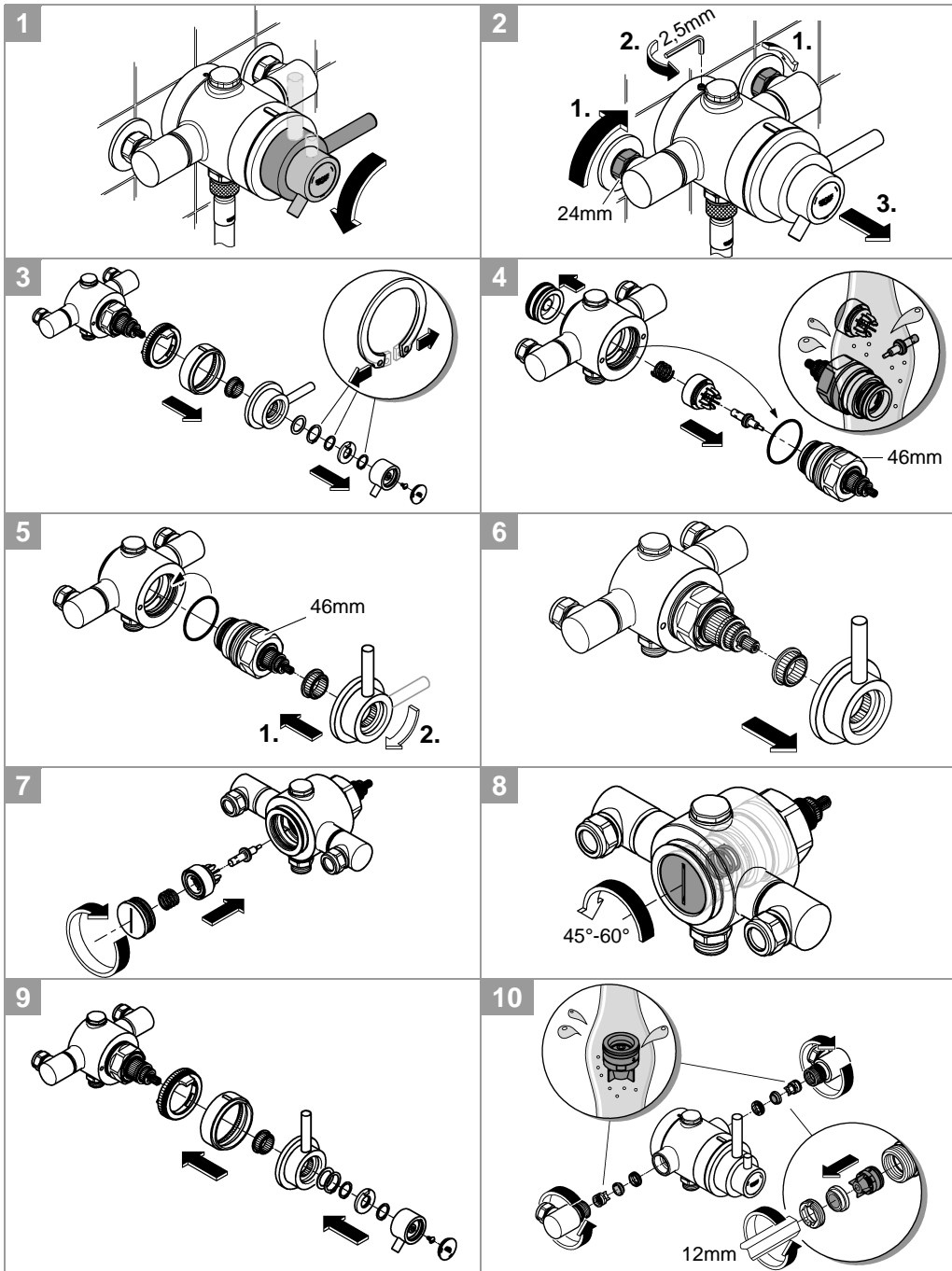

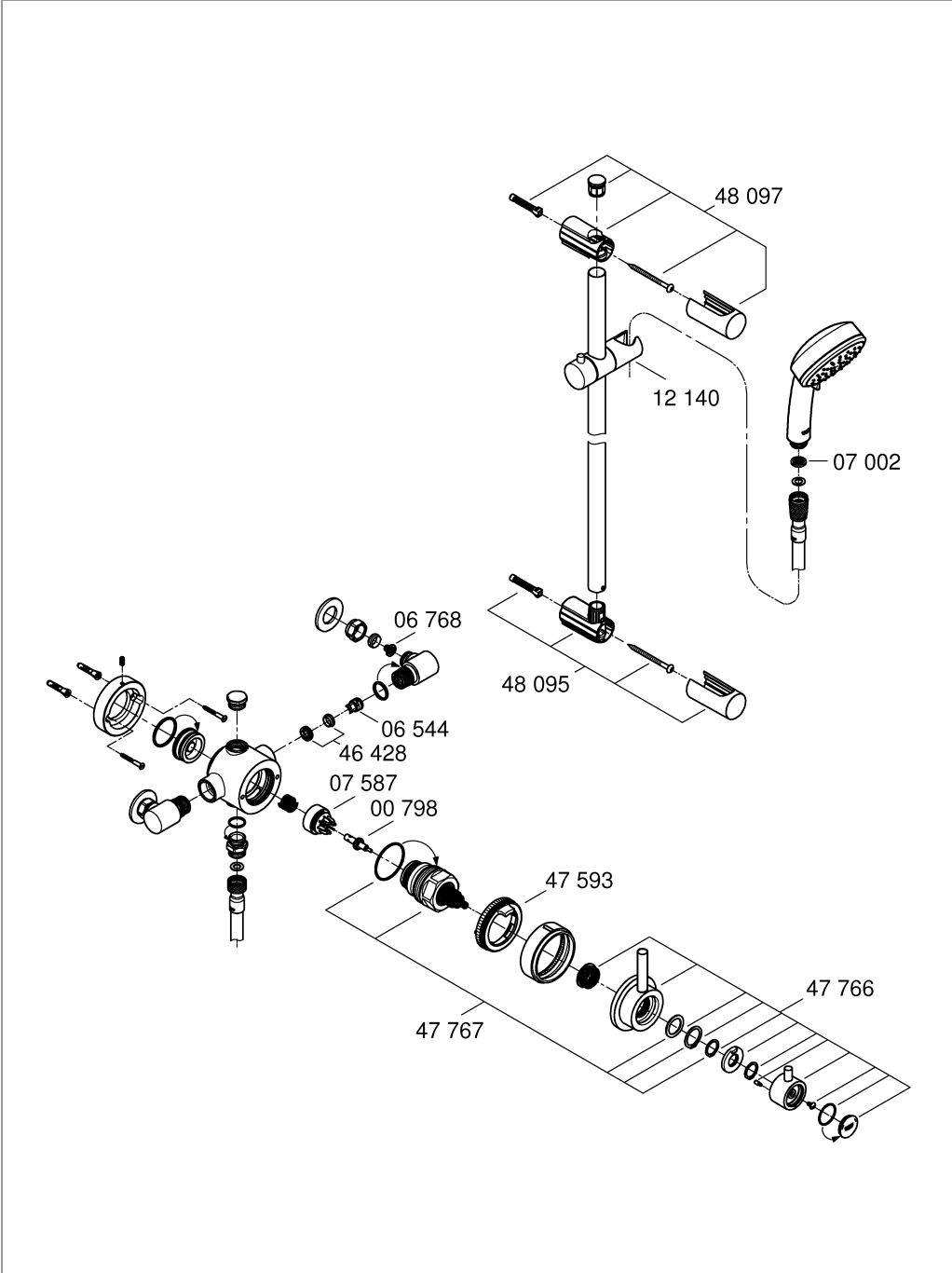

Pure Freude an Wasser

GROHE

(D)

☎ +49 571 3989 333
impressum@grohe.de

(A)

☎ +43 1 68060
info-at@grohe.com

(AUS)

Argent Sydney
☎ +(02) 8394 5800
Argent Melbourne
☎ +(03) 9682 1231

(B)

☎ +32 16 230660
info.be@grohe.com

(BG)

☎ +359 2 9719959
grohe-bulgaria@grohe.com

(CAU)

☎ +99 412 497 09 74
info-az@grohe.com

(CDN)

☎ +1 888 6447643
info@grohe.ca

(CH)

☎ +41 448777300
info@grohe.ch

(CN)

☎ +86 21 63758878

(CY)

☎ +357 22 465200
info@grome.com

(CZ)

☎ +420 277 004 190
grohe-cz@grohe.com

(DK)

☎ +45 44 656800
grohe@grohe.dk

(E)

☎ +34 93 3368850
grohe@grohe.es

(EST)

☎ +372 6616354
grohe@grohe.ee

(F)

☎ +33 1 49972900
marketing-fr@grohe.com

(FIN)

☎ +358 10 8201100
teknocalor@teknocalor.fi

(GB)

☎ +44 871 200 3414
info-uk@grohe.com

(GR)

☎ +30 210 2712908
nsapountzis@ath.forthnet.gr

(H)

☎ +36 1 2388045
info-hu@grohe.com

(HK)

☎ +852 2969 7067
info@grohe.hk

(I)

☎ +39 2 959401
info-it@grohe.com

(IND)

☎ +91 124 4933000
customercare.in@grohe.com

(IS)

☎ +354 515 4000
jonst@byko.is

(J)

☎ +81 3 32989730
info@grohe.co.jp

(KZ)

☎ +7 727 311 07 39
info-cac@grohe.com

(LT)

☎ +372 6616354
grohe@grohe.ee

(LV)

☎ +372 6616354
grohe@grohe.ee

(MAL)

☎ +1 800 80 6570
info-singapore@grohe.com

(N)

☎ +47 22 072070
grohe@grohe.no

(NL)

☎ +31 79 3680133
vragen-nl@grohe.com

(NZ)

☎ +09/373 4324

(P)

☎ +351 234 529620
commercial-pt@grohe.com

(PL)

☎ +48 22 5432640
biuro@grohe.com.pl

(RI)

☎ +62 21 2358 4751
info-singapore@grohe.com

(RO)

☎ +40 21 2125050
info-ro@grohe.com

(ROK)

☎ +82 2 559 0790
info-singapore@grohe.com

(RP)

☎ +63 2 8041617

(RUS)

☎ +7 495 9819510
info@grohe.ru

(S)

☎ +46 771 141314
grohe@grohe.se

(SGP)

☎ +65 6 7385585
info-singapore@grohe.com

(SK)

☎ +420 277 004 190
grohe-cz@grohe.com

(T)

☎ +66 2610 3685
info-singapore@grohe.com

(TR)

☎ +90 216 441 23 70
GroheTurkey@grome.com

(UA)

☎ +38 44 5375273
info-ua@grohe.com

(USA)

☎ +1 800 4447643
us-customerservice@grohe.com

(VN)

☎ +84 8 5413 6840
info-singapore@grohe.com

(AL)

(BIH)

(HR)

(KS)

(ME)

(MK)

(SLO)

(SRB)

☎ +385 1 2911470
adria-hr@grohe.com

(IR)

(OM)

(UAE)

(YEM)

☎ +971 4 3318070
grohedubai@grome.com

**Eastern Mediterranean,
Middle East - Africa
Area Sales Office:**

☎ +357 22 465200
info@grome.com

Far East Area Sales Office:

☎ +65 6311 3600
info@grohe.com.sg

www.grohe.com

2014/03/21