

*Pure Freude
an Wasser*



PERFECT MATCH

GROHE CERAMICS MADE TO MATCH
IN FORM AND FUNCTION



CONTENTS

LEARN MORE ABOUT THE WORLD OF GROHE CERAMICS	02
KEY TECHNOLOGIES	12
BAU CERAMIC	24
INSPIRATION	26
COLLECTION	32
EURO CERAMIC	38
INSPIRATION	40
COLLECTION	46
CUBE CERAMIC	52
INSPIRATION	54
COLLECTION	60
UNIVERSAL SHOWER TRAYS	66
COLLECTION	68
LINE OVERVIEW	70
MATCHING FAUCET LINES	72
RECOMMENDATIONS	74
TECHNICAL DRAWINGS	76
GROHE BRAND	98





GROHE NOW ENTERS
THE WORLD OF CERAMICS
**CREATING PERFECTLY
COORDINATED BATHROOMS**

“We believe that a complete bathroom solution is the key to customer satisfaction.”

MICHAEL RAUTERKUS, GROHE AG CEO



GROHE CERAMICS: MADE TO MATCH IN FORM AND FUNCTION

Finding a perfect match isn't easy. That's also true for the bathroom. Because our ceramics come with a selection of recommended combinations that fit our faucets, showers and sanitary systems they complement one other in both design and technology: the overwhelming variety of options is distilled into one simple choice. Save yourself the trial and error and make only one easy choice: for a perfect match.

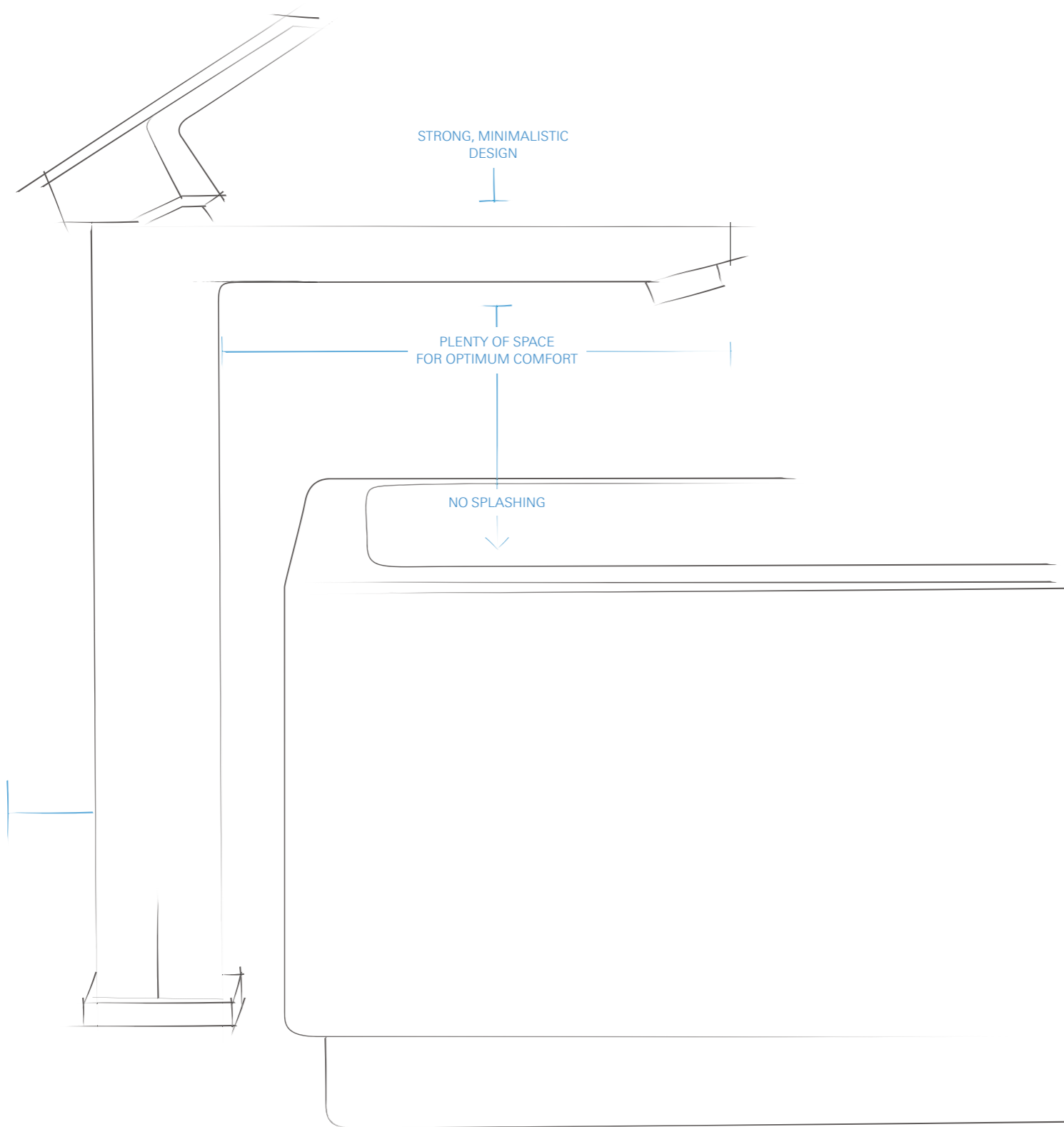

OUR ASPIRATION IS PERFECTION IN EVERY DETAIL **THAT'S WHY WE CREATED PERFECT MATCHES**

With GROHE Ceramics there is no need to rely on guesswork. Our dedicated design team looked at each individual product to determine which faucet and basin shapes look best together, guaranteeing you a seamless, complete design aesthetic. In addition, we physically tested our products against three criteria to make sure every suggested combination offers you a perfect match:

- Easy installation
- No splashing during handwashing
- Plenty of space for optimum comfort

“We wanted to establish a natural relationship between two objects.”

MICHAEL SEUM, GROHE VICE PRESIDENT DESIGN



**WE ARE CONVINCED THAT
TWO ELEMENTS CAN
ACHIEVE PERFECT BALANCE**
LET OUR IDEAL COMBINATIONS
SURROUND YOU WITH SERENITY

“Only a perfect match can give
design the presence it deserves.”

MICHAEL SEUM, GROHE VICE PRESIDENT DESIGN



AS PART OF THE STRONG LIXIL GROUP THIS VISION COMES TRUE **BY COMBINING OUR KNOWLEDGE IN DESIGN AND TECHNOLOGY**

Together we're stronger. We combined our GROHE expertise as a world leader in sanitary fittings with the unique technology and insights from LIXIL's other Water Technology brands.

Over fifteen ceramic manufactories belong to the LIXIL group, making it one of the biggest suppliers of sanitary ceramics in the world. This now allows GROHE to offer a complete bathroom solution, featuring innovative products like shower toilets and SmartControl showers, alongside revolutionary technologies such as Triple Vortex. Beautiful, functional and reliable, LIXIL's products and solutions are changing the way people live, all over the world.

“Our affiliation to one of the leading manufacturers of sanitary ceramics worldwide makes us very proud.”

MICHAEL RAUTERKUS, GROHE AG CEO

OUR COMPELLING TECHNOLOGIES

You may not see it at first sight – but our ceramics are equipped with the most advanced technology. At GROHE it is our aspiration to make your time in the bathroom as comfortable as possible without any restrictions. Discover our innovative GROHE technologies.



PUREGUARD
STAYS SPARKLING WHITE – NO CHANCE FOR BACTERIA AND DIRT



TRIPLE VORTEX FLUSH
THE POWER OF THREE: CLEAN AND SILENT

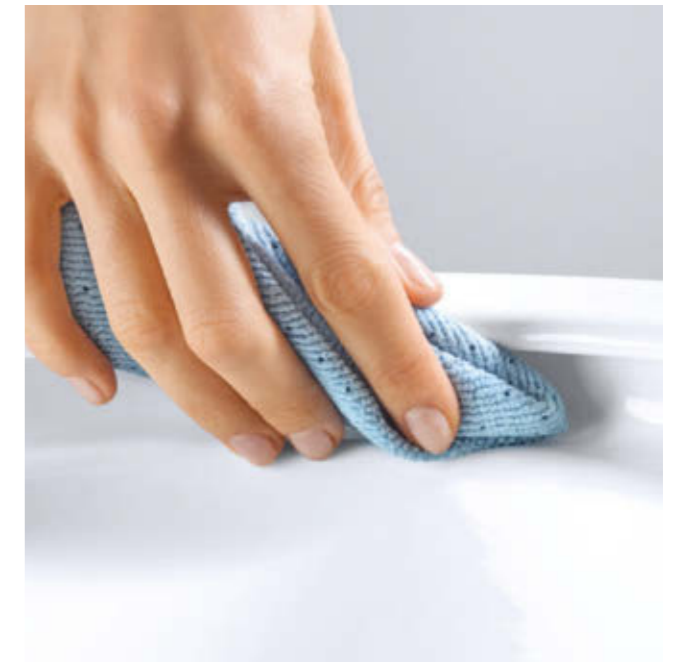

RIMLESS TECHNOLOGY
LEAVES BACTERIA NOWHERE TO HIDE



QUICK RELEASE SEAT
FAST REMOVAL FOR EASY CLEANING



SEAT & COVER SOFT CLOSE
GENTLE AND QUIET

PUREGUARD STAYS SPARKLING WHITE – NO CHANCE FOR BACTERIA AND DIRT

Thanks to GROHE PureGuard, Euro Ceramic and Cube Ceramic come with an enduring sparkling finish. Long-lasting ions with an anti-bacterial effect prevent bacteria growth and keep your ceramics clean and germ-free. The smooth surface also locks out dirt resulting from limescale and grime and is effortless to clean.

- Keeps your ceramics clean and sparkling white
- Anti-bacterial ions prevent bacteria growth



PUREGUARD

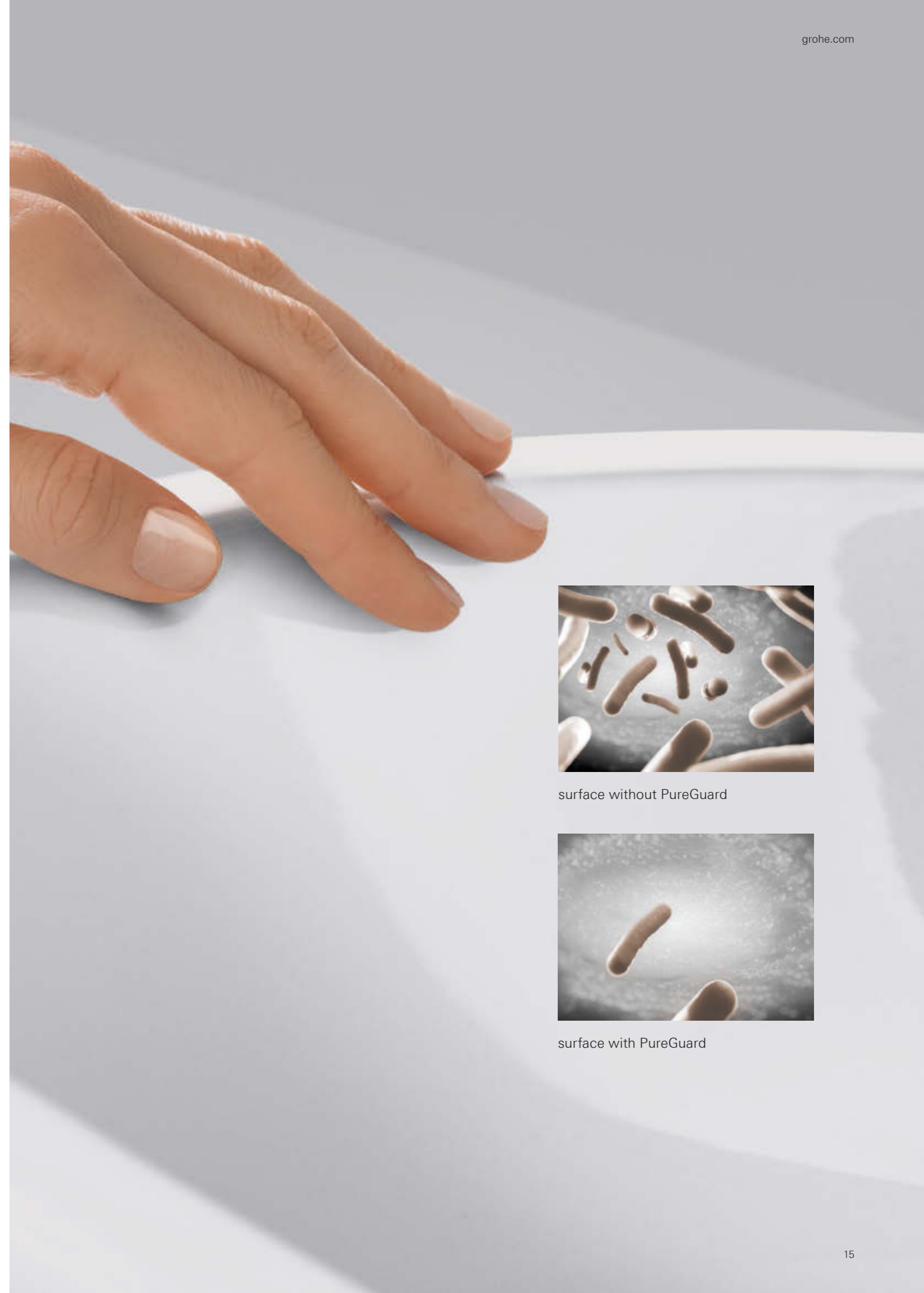

surface without PureGuard



surface with PureGuard

TRIPLE VORTEX

THE POWER OF THREE: CLEAN AND SILENT

Unlike other toilets, GROHE's innovative Triple Vortex flush system creates a powerful but silent vortex of water that swirls to cover and clean the whole of the bowl. Despite its power, this effective system is unlikely to splash and has low water consumption, with a dual flush option that uses just 5 l of water and only 3 l for a short flush. Instead of one or two water outlets, the Triple Vortex system flushes from three outlets to create a powerful suction that leaves nothing behind.



TRIPLE VORTEX



RIMLESS TECHNOLOGY LEAVES BACTERIA NOWHERE TO HIDE

With GROHE rimless technology, every surface of your toilet is easy to reach and effortless to keep clean, even in places you can't see. It makes bacteria hiding in corners and crevices under the rim a thing of the past. GROHE rimless technology leaves bacteria nowhere to hide.

- The technology for fast and easy cleaning
- Available for all toilets of all three lines



RIMLESS TECHNOLOGY

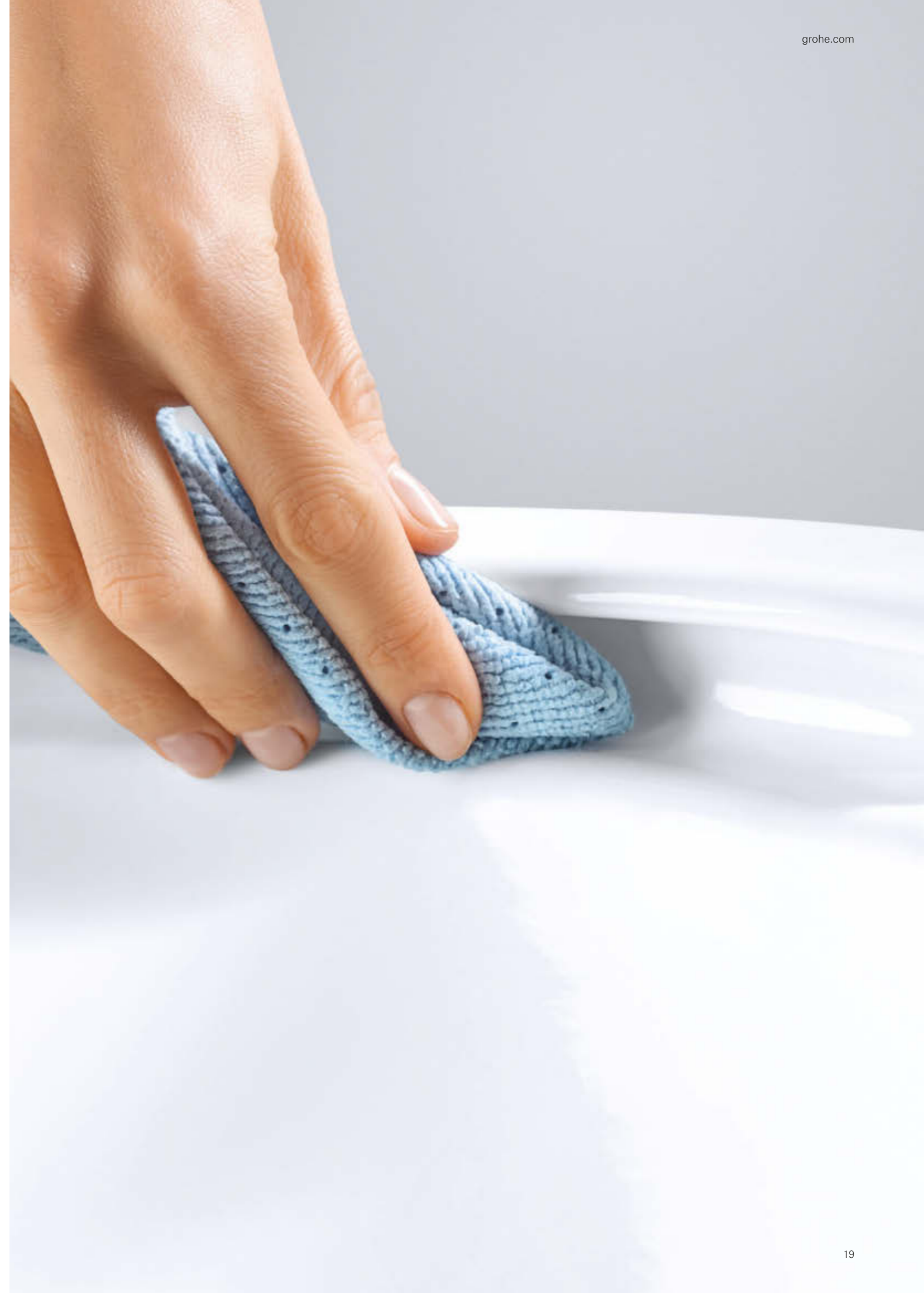



SOFT CLOSE SEAT GENTLE AND QUIET

Both seat and lid optionally have a gentle and quiet soft-closing mechanism to add a little more comfort. This user-friendly mechanism is durable and reliable making this WC an excellent choice for your project.

— Available for all toilets of all three lines



QUICK RELEASE SEAT EASY REMOVAL FOR EASY CLEANING

GROHE quick release seats come equipped with a special hinge that allows for easy removal of the toilet seat. It makes hidden spaces easily accessible for cleaning to keep the WC a hygienic and germ-free place.

— Available for all toilets of all three lines



PERFECT MATCH FOR YOUR BATHROOM



BAU CERAMIC – VERSATILITY FOR A MODERN LIFE

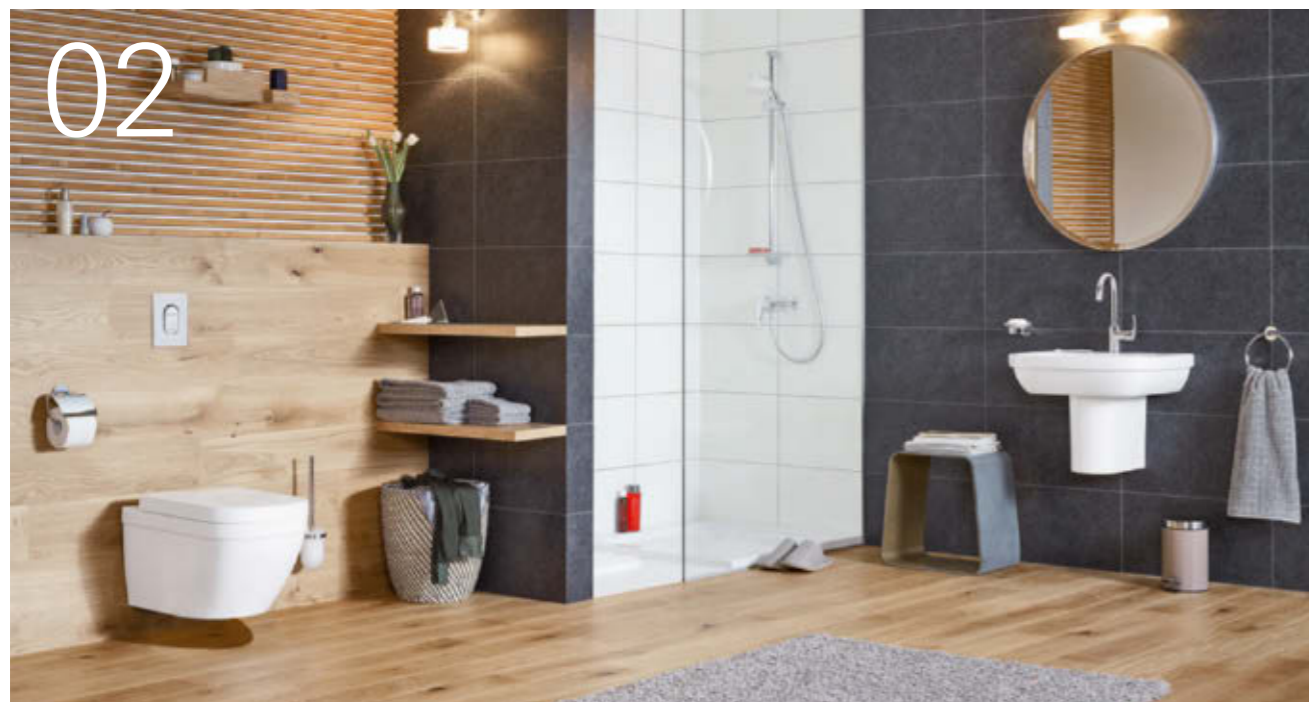

EURO CERAMIC – IN TUNE WITH MY LIFESTYLE

Create pure unison in your bathroom: with GROHE ceramics and GROHE shower trays. If you choose one of our perfect matches, you can be sure that you are composing a coherent and perfectly designed style.

Whatever your lifestyle, whatever your taste, you'll find the perfect combination of products within GROHE's three new ceramic ranges and the universal shower tray line. Each has its own distinctive qualities and creates a visually unified bathroom.



CUBE CERAMIC – A CLEAR STYLE STATEMENT



UNIVERSAL SHOWER TRAYS – MODERN DESIGN FOR ALL MOUNTING OPTIONS

01

BAU CERAMIC

- 39 421 000 Wall hung basin 60 cm
- 39 426 000 Semi pedestal
- 39 427 000 Wall hung WC
- 39 493 000 Seat & cover soft close
- 23 751 000 BauFlow S-Size Basin mixer
- 37 601 000 Nova Cosmopolitan S flush plate



BAU CERAMIC VERSATILITY FOR A MODERN LIFE

Every project needs a versatile design line that fits harmoniously into each bathroom interior. With its soft and round forms, Bau Ceramic is the perfect choice for the bathroom interiors of hotels, offices and residential housing. Its contemporary style makes it the perfect solution for your project, suiting every taste.

Bau Ceramic is a versatile all-rounder that offers state-of-the-art technology. By making all toilets rimless we made sure users benefit from the highest hygiene standards. This range will most certainly make your project a success.

— All toilets are rimless



RIMLESS TECHNOLOGY



QUICK RELEASE SEAT



SEAT & COVER SOFT CLOSE



39 438 000 Urinal concealed inlet
38 804 000 Nova Cosmopolitan Actuation plate

- Right **39 420 000** Wall hung basin 65 cm
- 23 753 000** BauFlow L-Size Basin mixer
- Top Left **39 424 000** Handrinse basin 45 cm
- 23 328 000** BauEdge S-Size Basin mixer
- Top Right **39 423 000** Undercounter basin 55 cm
- 23 758 000** BauEdge S-Size Basin mixer
- Bottom **39 421 000** Wall hung basin 60 cm
- 23 335 000** BauLoop S-Size Basin mixer



- | | | |
|-------|-------------------|---------------------------------|
| Left | 39 427 000 | Wall hung WC |
| | 39 493 000 | Seat & cover soft close |
| | 39 433 000 | Wall hung bidet |
| | 23 754 000 | BauFlow Bidet Mixer |
| | 37 601 000 | Nova Cosmopolitan S flush plate |
| Right | 39 421 000 | Wall hung basin 60 cm |
| | 23 751 000 | BauFlow S-Size Basin mixer |



A bathroom that appeals to everyone: its sleek forms make Bau Ceramic the ideal collection for residential and public buildings.

BAU CERAMIC COLLECTION

A clean and modern design can be truly appealing – that’s why we gave Bau Ceramic an understated look. This collection offers a complete bathroom solution including a wide range of basins of different sizes and mounting options.

Thanks to GROHE rimless technology, all toilets of this range are effortless to clean. Every Bau Ceramic toilet is equipped with a soft closing and quickly released seat. When you choose this collection, you can be sure to have everything covered for your project business – at an attractive price.



39 420 000
Wall hung basin
65 cm



39 421 000
Wall hung basin
60 cm



39 440 000
Wall hung basin
55 cm



39 424 000
Handrinse basin
45 cm



39 422 000
Drop in basin
55 cm



39 423 000
Undercounter basin
55 cm

39 421 000
Wall hung basin
60 cm



39 426 000
Semi pedestal for wash basins



39 425 000
Pedestal for wash basins



39 427 000
Wall hung WC
rimless
wash down
39 491 000
open rim



39 427 000
Wall hung WC
rimless
wash down
39 491 000
open rim



39 433 000
Wall hung bidet



39 432 000
Floorstanding bidet



39 438 000
Urinal concealed inlet
39 439 000
Top inlet



39 430 000
Floorstanding WC
rimless
wash down
horizontal outlet
39 431 000
Vertical outlet



39 492 000
Seat & cover
Quick release function
39 493 000
soft close



39 351 000
Wall hung WC
rimless
Seat & cover soft close
Quick release function
39 497 000
boxed rim
Seat & Cover w/o soft close



39 347 000
 WC closed coupled combination:
 WC, boxed rim, horizontal outlet (39 428 000)
 Cistern side inlet (39 437 000)
 Seat & cover soft close (39 493 000)
39 495 000
 Cistern side inlet, NF (39 494 000)
 Seat & cover (39 492 000)



39 346 000
 WC closed coupled combination:
 WC, rimless, vertical outlet (39 429 000)
 Cistern side inlet (39 437 000)
 Seat & cover soft close (39 493 000)
39 496 000
 WC, rimless, horizontal outlet (39 349 000)
 Cistern side inlet, NF (39 494 000)



39 349 000
 Floorstanding WC for closed coupled combination
 rimless, wash down, horizontal outlet
39 428 000
 Boxed rim



39 429 000
 Floorstanding WC for closed coupled combination
 rimless, wash down, vertical outlet



39 436 000
 Cistern with bottom inlet
39 437 000
 Side inlet
39 494 000
 Cistern with side inlet NF



39 492 000
 Seat & cover
 Quick release function
39 493 000
 soft close

02

EURO CERAMIC

- 39 323 000 Wall hung basin 65 cm
- 39 201 000 Semi pedestal for wash basins
- 39 328 000 Wall hung WC
- 39 330 000 Seat & cover soft close
- 23 537 002 Eurosmart L-Size Basin mixer
- 37 624 000 Arena Cosmopolitan S flush plate
- 33 555 002 Eurosmart shower mixer
- 27 796 001 New Tempesta 100 shower rail set with hand shower 3 sprays rail 900 mm
- 27 596 000 GROHE EasyReach tray
- 39 301 000 Universal shower tray 90 x 90

EURO CERAMIC

IN TUNE WITH MY LIFESTYLE

Imagine a great looking bathroom which adapts effortlessly to your real life, where you start and end your day in a personal space. A bathroom which is both hugely practical but also fun and visually distinctive.

The Euro Ceramic range has been specially designed to match up an excellent performance with an attractive price. You can enjoy a flexible and stylish bathroom day in, day out for years to come.

- Unique surface technology PureGuard – optional
- All toilets have Triple Vortex flush*
- All toilets are rimless



PUREGUARD



TRIPLE VORTEX FLUSH



RIMLESS TECHNOLOGY



QUICK RELEASE SEAT



SEAT & COVER SOFT CLOSE

* except floorstanding WC



39 328 000 Wall hung WC
39 330 000 Seat & cover soft close
37 624 000 Arena Cosmopolitan S Flush plate

Left **39 338 000** Floorstanding WC close coupled in combination with cistern **39 332 000**
Bottom **39 323 000** Wall hung basin 65 cm
23 537 002 Eurosmart L-Size Basin mixer



- Right **39 323 000** Wall hung basin 65 cm
- 23 322 001** Eurosmart M-Size Basin mixer
- Top Left **39 337 000** Countertop basin 60 cm
- 23 537 002** Eurosmart L-Size Basin mixer



Discreet style to inspire. Good design doesn't need to shout. The flowing lines of Euro Ceramic effortlessly create a relaxing bathroom.



EURO CERAMIC COLLECTION

Open up your bathroom to create a calming retreat that fosters thought, relaxation and well-being: with the Euro Ceramic range. This collection offers everything you need for bathroom solutions, especially small ones. All basins and toilets of this collection have a compact size and design to use space most effectively. The innovative surface technology PureGuard is available as an option.



39 323 000
39 323 00H*
Wall hung basin
65 cm



39 335 000
39 335 00H*
Wall hung basin
60 cm



39 336 000
39 336 00H*
Wall hung basin
55 cm



39 337 000
39 337 00H*
Countertop basin
60 cm



39 324 000
39 324 00H*
Handrinse basin
45 cm



39 327 000
39 327 00H*
Mini handrinse basin
37 cm



39 335 000
39 335 00H*
Wall hung basin
60 cm



39 423 000
Undercounter basin
55 cm



39 201 000
Semi pedestal for wash basins
for handrinse basin
39 325 000
for handrinse basin
45 cm



39 202 000
Pedestal for wash basins

* With PureGuard



39 328 000
39 328 00H*
 Wall hung WC
 Triple Vortex
 wash down



39 328 000
39 328 00H*
 Wall hung WC
 Triple Vortex
 wash down



39 206 000
39 206 00H*
 Compact wall hung WC
 Triple Vortex
 wash down



39 329 000
39 329 00H*
 Floorstanding WC
 rimless
 wash down
 universal outlet



39 339 000
39 339 00H*
 Floorstanding WC
 back to wall
 Triple Vortex
 wash down
 universal outlet



39 331 000
 Seat & cover
 Quick release function
39 330 000
 soft close
39 459 000
 Seat & cover for compact WC
 Quick release function
39 458 000
 soft close



39 208 000
39 208 00H*
 Wall hung bidet



39 340 000
39 340 00H*
 Floorstanding bidet

* With PureGuard



39 462 000
39 462 00H* **

WC closed coupled combination:
WC, rimless, Triple Vortex, wash down,
universal outlet (39 338 000 / 39 338 00H)
Cistern side & back inlet, NF (39 531 000)
Seat & cover soft close (39 330 000)



39 338 000
39 338 00H*

Floorstanding WC for closed coupled combination
triple vortex, wash down, universal outlet



39 332 000
Cistern with bottom inlet

39 333 000
Cistern with side and back inlet

39 531 000
Cistern with side and back inlet, NF



39 331 000

Seat & cover
Quick release function

39 330 000
soft close

* With PureGuard
** available April 2018

03

CUBE CERAMIC

- 39 476 00H Countertop basin 80 cm
- 39 244 00H Wall hung WC wash down
- 39 488 000 Seat & cover soft close
- 39 486 00H Wall hung bidet
- 23 445 000 Eurocube M-Size Basin mixer
- 37 535 000 Skate Cosmopolitan S flush plate
- 23 138 000 Eurocube Bidet mixer
- 34 706 000 Perfect shower set with Rainshower 310 SmartActive Cube
- 19 897 000 Eurocube 4-hole bath combination

CUBE CERAMIC

A CLEAR STYLE STATEMENT

Step away from a busy, cosmopolitan life for a moment and enjoy the essentials. With its strong, minimalist lines, the stunning Cube Ceramic collection sums up cool and contemporary bathroom luxury. Every product in the collection has a sophisticated feel, modelled on the crisp, clean lines of the cube. The dynamic shapes and smooth surfaces are designed to be fuss-free, ideal for creating a modern bathroom scheme that brings a sense of calm clarity to your day.

- Unique surface technology PureGuard
- Toilet range offers rimless and Triple Vortex technologies



PUREGUARD



TRIPLE VORTEX FLUSH



RIMLESS TECHNOLOGY



QUICK RELEASE SEAT



SEAT & COVER SOFT CLOSE



39 473 00H Wall hung basin 60 cm
 23 445 000 Eurocube M-Size Basin mixer
 40 624 001 Double towel bar 439 mm

- Left **39 244 00H** Wall hung WC
39 374 KSO Glass Cover Skate Cosmopolitan
- Top **39 486 00H** Wall hung bidet
39 244 00H Wall hung WC
37 535 000 Skate Cosmopolitan S Flush plate
- Bottom **23 138 000** Eurocube S-Size Bidet mixer
39 473 00H Wall hung basin 60 cm
20 351 000 M-Size 3-hole Basin mixer



Right	39 479 00H	Countertop built-in basin 60 cm
	23 445 000	Eurocube M-Size Basin mixer
Top Left	39 478 00H	Countertop basin 50 cm
	20 351 000	Eurocube M-Size 3-hole Basin mixer
Top Right	39 482 00H	Vessel basin 40 cm
	19 895 000	Eurocube M-Size Basin mixer wall mounted 171 mm



Be inspired by the timeless quality of architectural design. The Cube Ceramic range of basin designs has been created to suit your personal style and routine, but all are united by crisp profiles and clean corners for an effortlessly contemporary look.



CUBE CERAMIC COLLECTION

With ceramics from the Cube Ceramic range, you create a bathroom scheme that makes the best out of effortless chic and contemporary design. Generously proportioned, its distinctive basins turn your bathroom into a welcoming urban oasis. Take a time-off from the hectic world outside and let the shapes of the city inspire you.

39 473 00H
Wall hung basin
60 cm



39 386 00H
Wall hung basin
100 cm



39 469 00H
Wall hung basin
80 cm



39 474 00H
Wall hung basin
50 cm



39 475 00H
Countertop basin
100 cm



39 476 00H
Countertop basin
80 cm



39 477 00H
Countertop basin
60 cm



39 478 00H
Countertop basin
50 cm



39 479 00H
Drop-in basin
60 cm



39 480 00H
Undercounter basin
50 cm



39 244 00H
Wall hung WC
Triple Vortex
wash down



39 481 00H
Vessel basin
50 cm



39 482 00H
Vessel basin
40 cm



39 483 00H
Handrinse basin
45 cm



39 244 00H
Wall hung WC
Triple Vortex
wash down



39 485 00H
Floorstanding WC back to wall
rimless
wash down



39 486 00H
Wall hung bidet



39 487 00H
Floorstanding bidet



39 488 000
Seat & cover
Quick release
soft close



39 484 00H
 Floorstanding WC for closed coupled combination
 rimless
 wash down
 universal outlet



39 490 000
 Cistern with bottom inlet
39 489 000
 with side inlet



39 488 000
 Seat & cover
 Quick release
 soft close

04

UNIVERSAL SHOWER TRAYS

- 39 301 000* Universal shower tray 90 cm x 90 cm
- 49 533 000* Waste set vertical for Universal shower trays
- 23 758 000 BauEdge M-Size Basin mixer with pop up waste set
- 23 331 000 BauEdge Bidet mixer with pop up waste set
- 37 601 000 Nova Cosmopolitan S flush plate
- 23 333 000 BauEdge Shower mixer
- 27 646 001 New Tempesta 100 shower rail set with hand shower 2 sprays rail 900 mm
- 27 596 000 GROHE EasyReach tray

UNIVERSAL SHOWER TRAY COLLECTION

MODERN DESIGN FOR ALL MOUNTING OPTIONS

To complement the ceramic ranges GROHE also offers a collection of universal, acrylic shower trays. This contemporary design solution fits both Euro Ceramic and Bau Ceramic. Every shower tray comes with a very flat entry with an inner depth of three centimetres. And there's more: this collection is especially versatile as it includes various sizes and suits all mounting options.



39 300 000
Universal shower tray 100 cm x 100 cm



39 301 000
Universal shower tray 90 cm x 90 cm



39 302 000
Universal shower tray 80 cm x 80 cm



39 307 000
Universal shower tray 90 cm x 140 cm



39 305 000
Universal shower tray 80 cm x 120 cm



39 306 000
Universal shower tray 80 cm x 100 cm



39 308 000
Universal shower tray 90 cm x 120 cm



49 533 000
Waste set vertical for Universal shower trays



49 534 000
Waste set horizontal for Universal shower trays

OVERVIEW OF ALL THREE LINES



PUREGUARD
STAYS SPARKLING WHITE –
NO CHANCE FOR BACTERIA AND DIRT



TRIPLE VORTEX FLUSH
THE POWER OF THREE: CLEAN AND SILENT



RIMLESS TECHNOLOGY
LEAVES BACTERIA NOWHERE TO HIDE



SOFT CLOSE SEAT
GENTLE AND QUIET



QUICK RELEASE SEAT
EASY REMOVAL FOR EASY CLEANING

BAU CERAMIC
VERSATILITY FOR A MODERN LIFE

EURO CERAMIC
IN TUNE WITH MY LIFESTYLE

CUBE CERAMIC
A CLEAR STYLE STATEMENT



Exceptionally smooth, hardwearing finish prevents bacteria growth

Natural anti-bacterial ions inhibit germs and prevent stains

Ceramic stays sparklingly clean and germ-free with the minimum of effort

Three water outlets in the bowl create a powerful vortex effect that leaves nothing behind

Every corner of the bowl is covered and cleaned

Very quiet flush

Less risk of splashing



No corners or crevices, which are playgrounds for bacteria



Both seat and lid have a gentle and quiet soft-closing mechanism



A special hinge allows easy removal of the toilet seat for cleaning

○ = optional

● = as standard

WITH OUR PERFECT MATCHES YOU CAN BE SURE THAT EVERYTHING FITS

A consistent design language and ergonomic use are essential for making your bathroom a place of true relaxation. With our perfect matches, we created three coordinated collections for a complete bathroom solution.

Each of our matches was tested to be perfect in design and function. Choose for yourself the line that most perfectly complements your personal style. Do you prefer the versatility of Bau Ceramic, the soft lines of Euro Ceramic or the modern and geometric shapes of Cube Ceramic?

For more information, visit ceramics.grohe.com



OUR RECOMMENDATIONS



BAU CERAMIC



EURO CERAMIC



CUBE CERAMIC

FAUCETS



BAUEDGE 23 328 000 BAULoop 23 335 000 BAUFLOW 23 751 000



EUROSMART 33 265 002 EUROSMART COSMOPOLITAN 32 825 00E EUROSTYLE 33 558 003 EUROSTYLE COSMOPOLITAN 23 039 002



EUROCUBE 23 127 000 LINEARE 32 114 001 ALLURE 32 757 000 ALLURE BRILLIANT 23 029 000

FLUSH PLATES



NOVA COSMOPOLITAN 38 765 000



ARENA COSMOPOLITAN 38 844 000



SKATE COSMOPOLITAN 37 535 000

ACCESSORIES



BAU COSMOPOLITAN TOWEL RING 40 460 001



ESSENTIALS TOWEL RING 40 365 001



SELECTION CUBE TOWEL RING 40 766 000

SHOWER TRAYS



UNIVERSAL SHOWER TRAY 90 CM X 90 CM 39 301 000*



UNIVERSAL SHOWER TRAY 80 CM X 120 CM 39 305 000*



UNIVERSAL SHOWER TRAY 100 CM X 100 CM 39 300 000*

* Launch Q3/2018

TECHNICAL DRAWINGS

To help you plan your bathroom down to the last detail, here are the important dimensions of all ceramic lines and shower tray collection.



BAU CERAMIC VERSATILITY FOR A MODERN LIFE

WASHBASIN

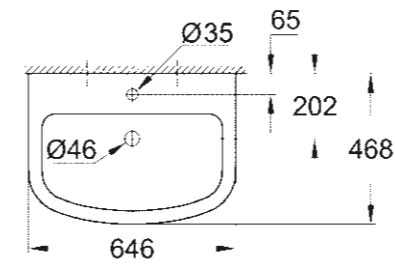

39 420 000
Wall hung basin
65 cm

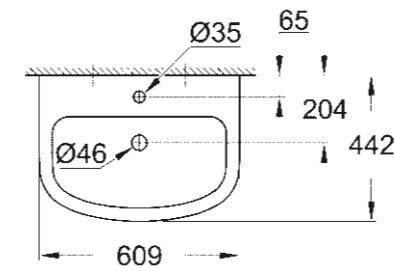

39 421 000
Wall hung basin
60 cm

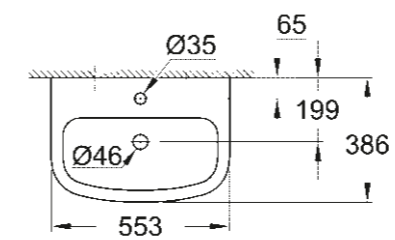

39 440 000
Wall hung basin
55 cm

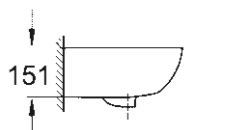
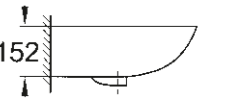
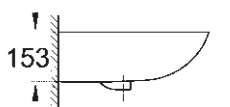
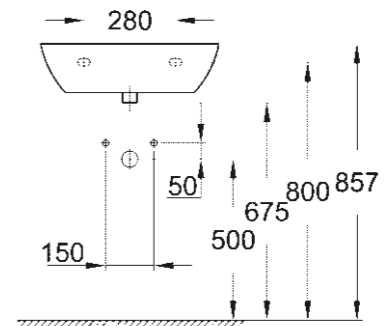
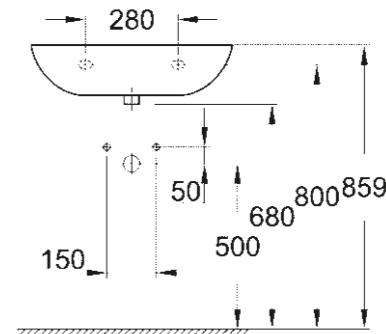
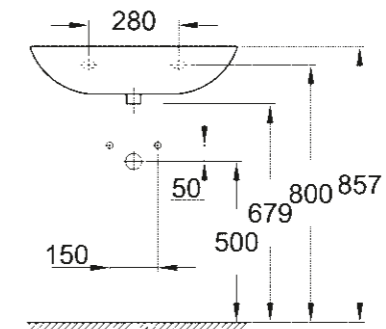

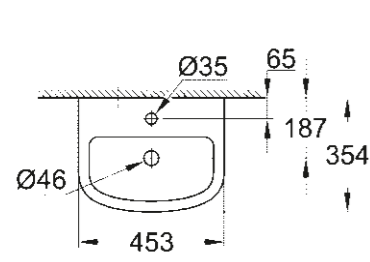

39 424 000
Handrinse basin
45 cm

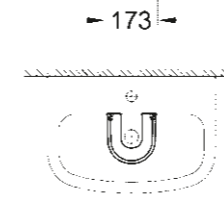
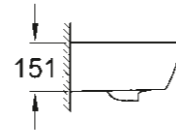
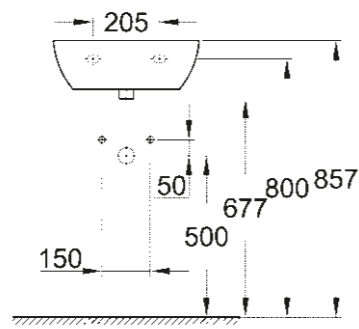

39 425 000
Pedestal for wash basins

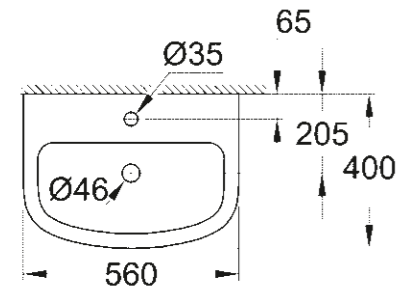
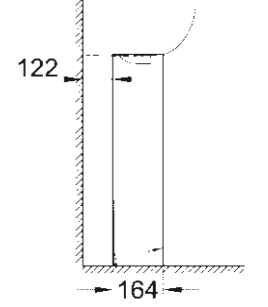
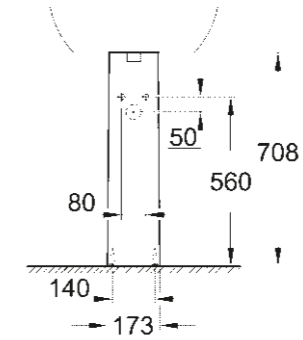

39 422 000
Drop in basin
55 cm

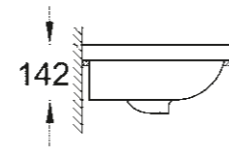
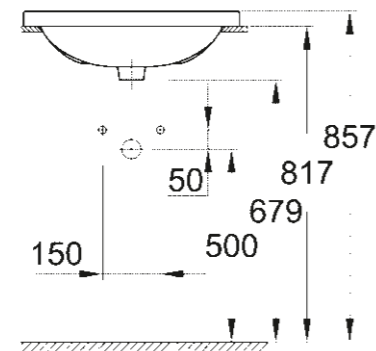

WC/CISTERN

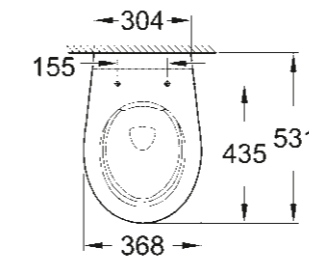

39 427 000
Wall hung WC
rimless

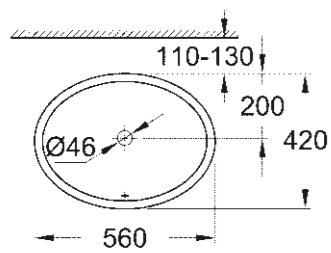
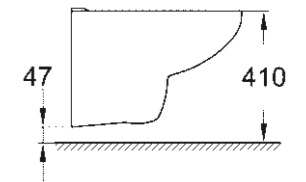
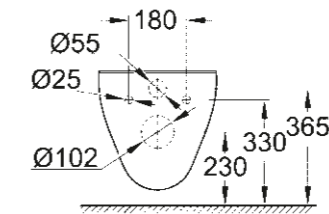

39 423 000
Undercounter basin
55 cm

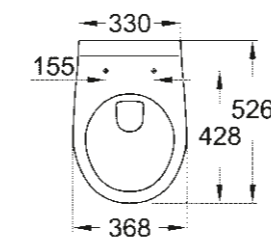
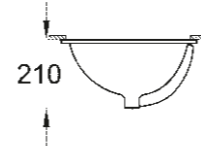
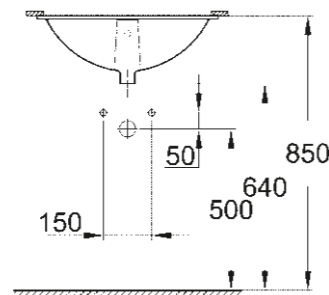

39 491 000
Wall hung WC
open rim

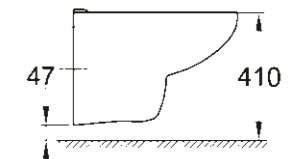
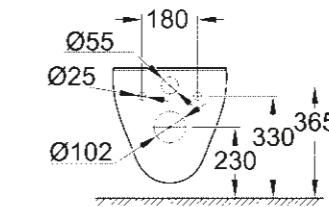

PEDESTAL

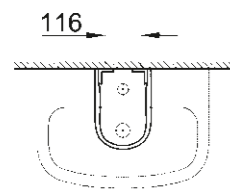

39 426 000
Semi pedestal for wash basins

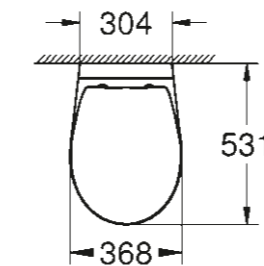
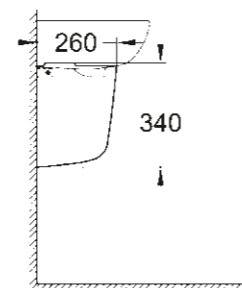
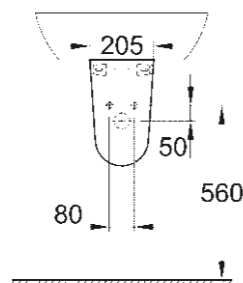

39 351 000
Wall hung WC
rimless
Seat & cover soft close
Quick release function

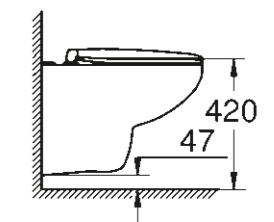
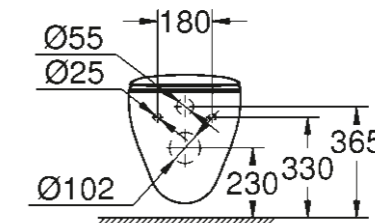

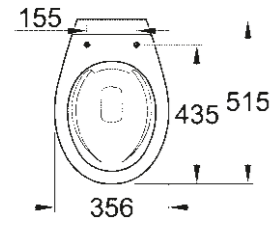

39 430 000
Floorstanding WC
rimless

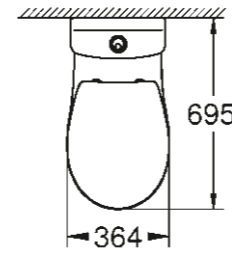
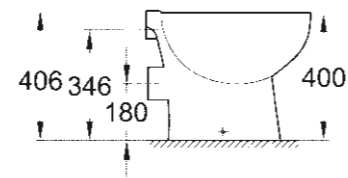
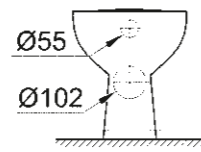

39 346 000
WC closed coupled combination:
WC, rimless, vertical outlet (39 429 000)
Cistern side inlet (39 437 000)
Seat & cover soft close (39 493 000)
39 496 000
Cistern side inlet, NF (39 494 000)

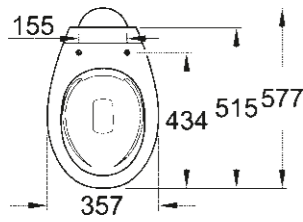
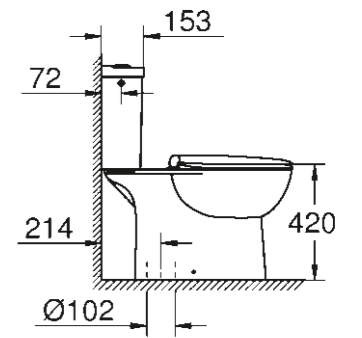
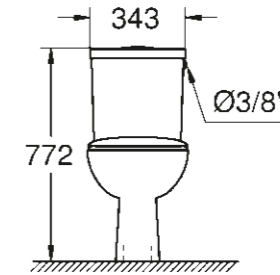

39 431 000
Floorstanding WC
rimless

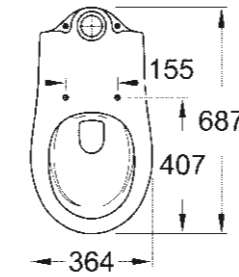
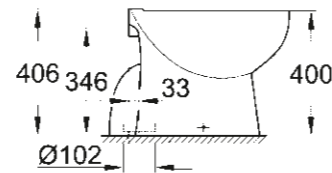
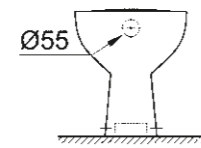

39 429 000
Floorstanding WC for closed coupled combination
rimless, vertical outlet

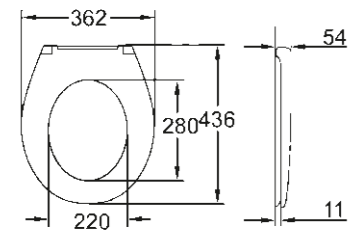
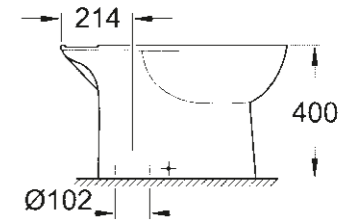
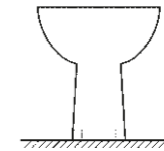

39 493 000
Seat & cover soft close
quick release function
39 492 000
w/o soft close
quick release function

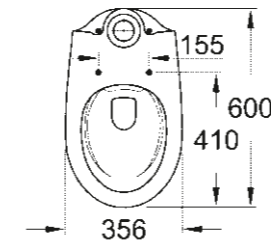

39 349 000
Floorstanding WC for closed coupled combination
rimless, horizontal outlet
39 428 000
boxed rim

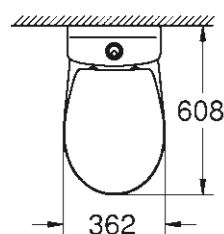
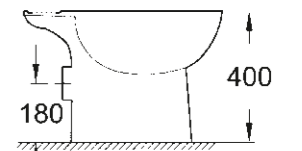
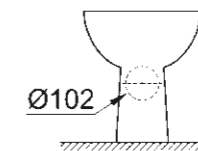

39 347 000
WC closed coupled combination:
WC, boxed rim, horizontal outlet (39 428 000)
Cistern side inlet (39 437 000), Seat & cover soft close (39 493 000)
39 495 000
Cistern side inlet, NF (39 494 000), Seat & cover (39 492 000)

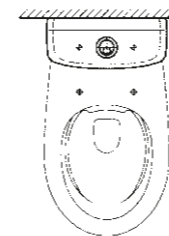
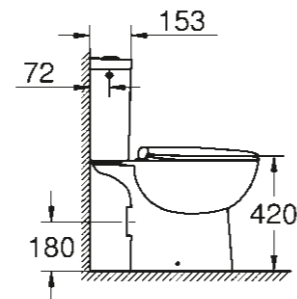
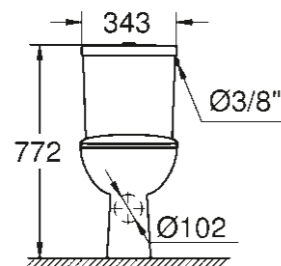

39 437 000
Cistern side inlet
39 494 000
Cistern side inlet, NF

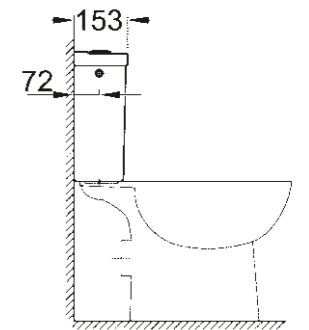
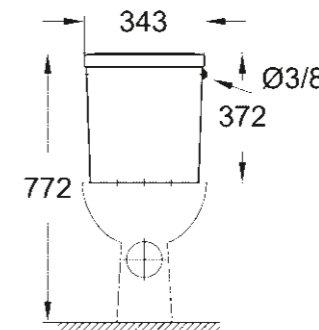

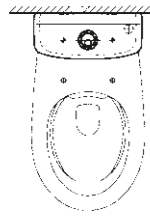

39 436 000
Cistern bottom inlet

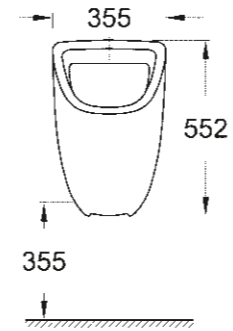
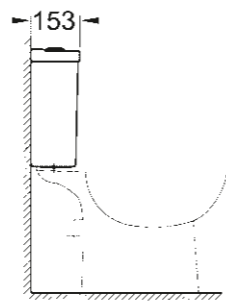
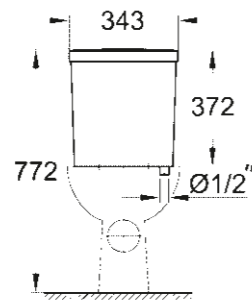

39 439 000
Urinal top inlet

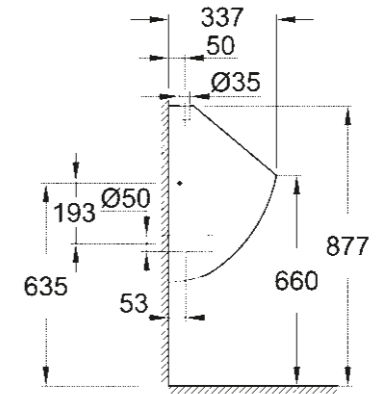

BIDET/URINAL

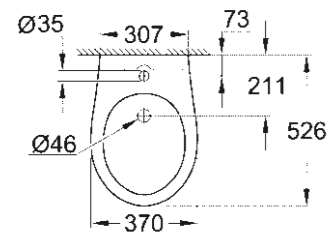

39 433 000
Wall hung bidet

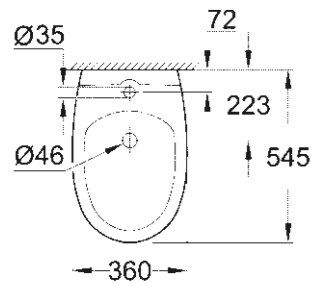
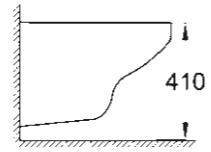
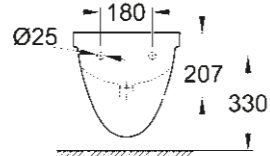

39 432 000
Floorstanding bidet

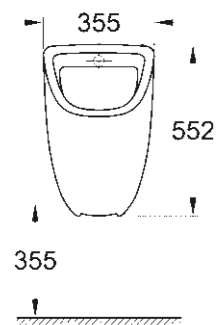
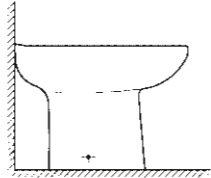
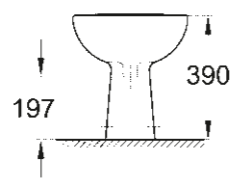

39 438 000
Urinal concealed inlet

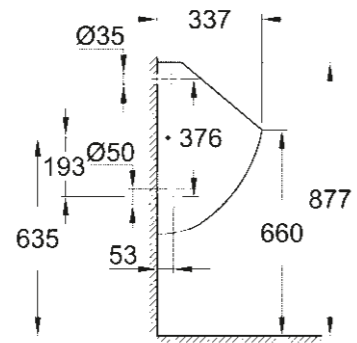

EURO CERAMIC IN TUNE WITH MY LIFESTYLE

WASHBASIN/PEDESTAL

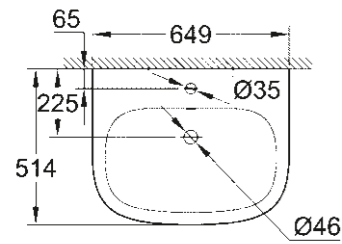

39 323 000
39 323 00H*
Wall hung basin
65 cm

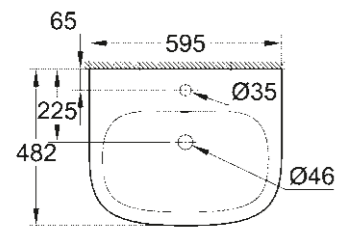
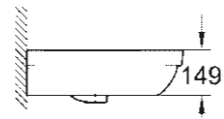
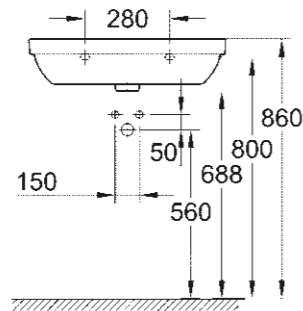

39 335 000
39 335 00H*
Wall hung basin
60 cm

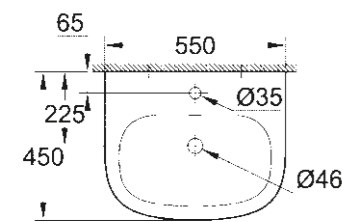
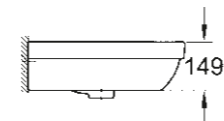
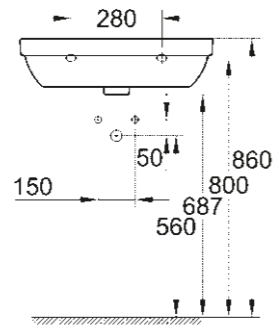

39 336 000
39 336 00H*
Wall hung basin
55 cm

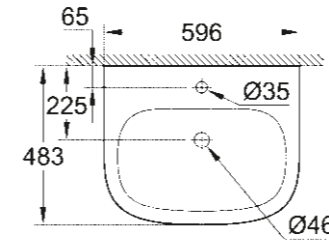
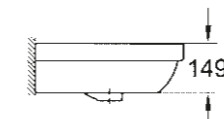
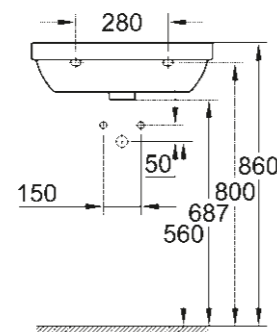

39 337 000
39 337 00H*
Countertop basin
60 cm

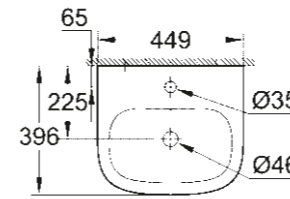
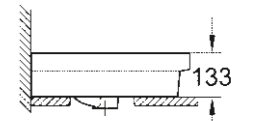
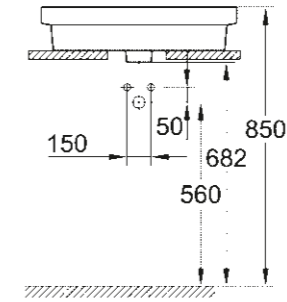

39 324 000
39 324 00H*
Handrinse basin
45 cm

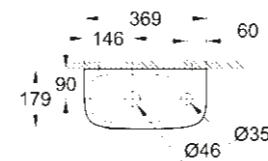
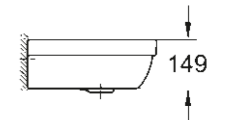
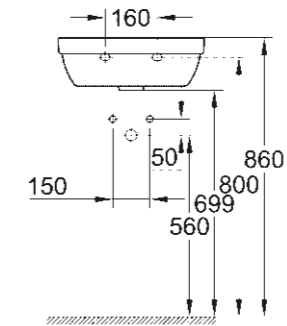

39 327 000
39 327 00H*
Mini handrinse basin
37 cm

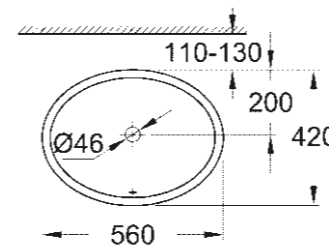
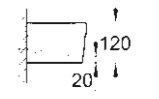
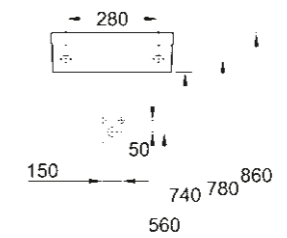

39 423 000
Undercounter basin
55 cm

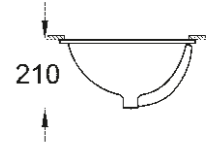
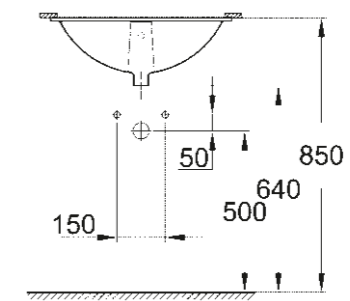

* With PureGuard

PEDESTAL

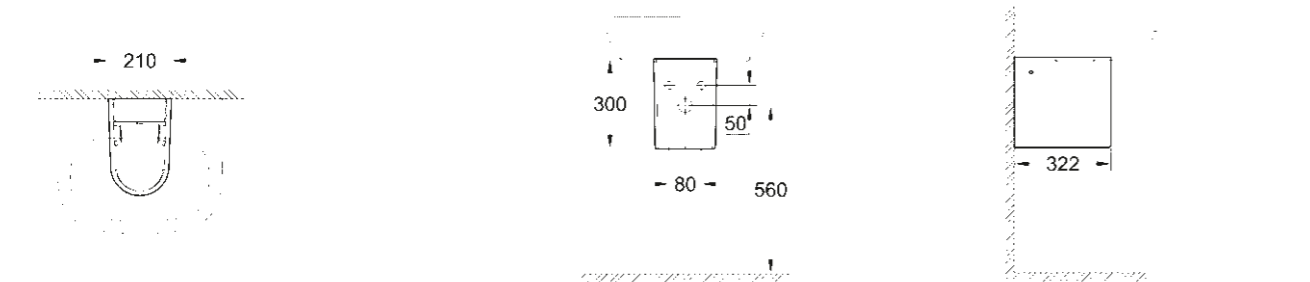

39 201 000
Semi pedestal for wash basins

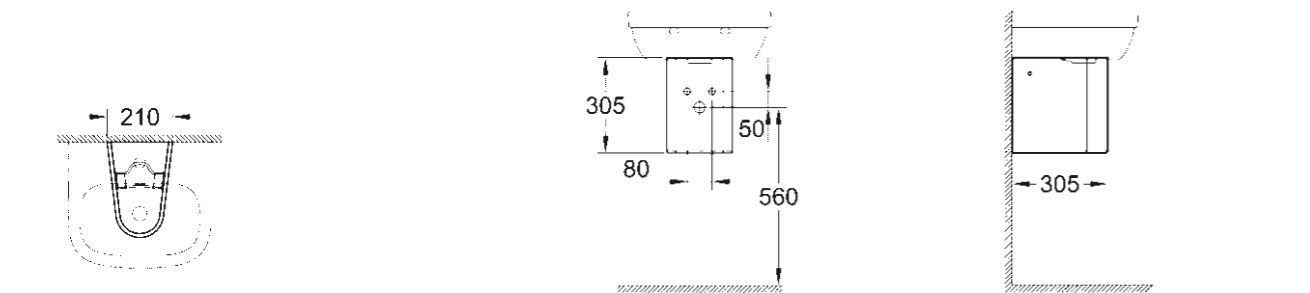

39 325 000
Semi pedestal for handrinse basin
45 cm

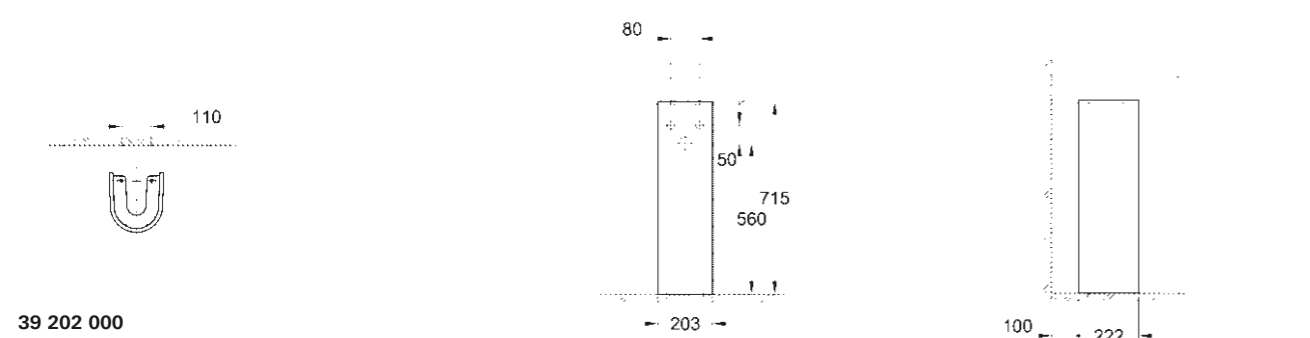

39 202 000
Pedestal for wash basins

WC/ BIDET

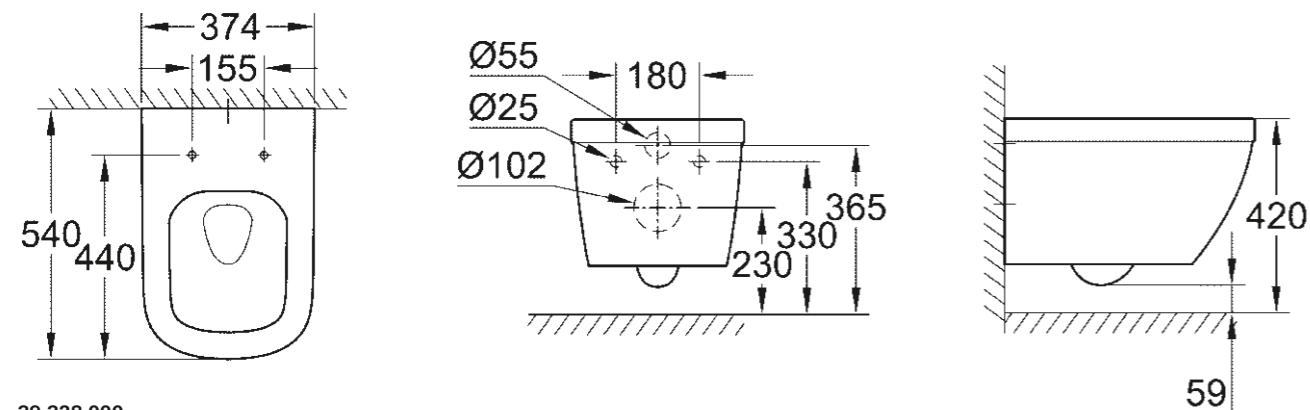

39 328 000
39 328 00H*
Wall hung WC
Triple Vortex

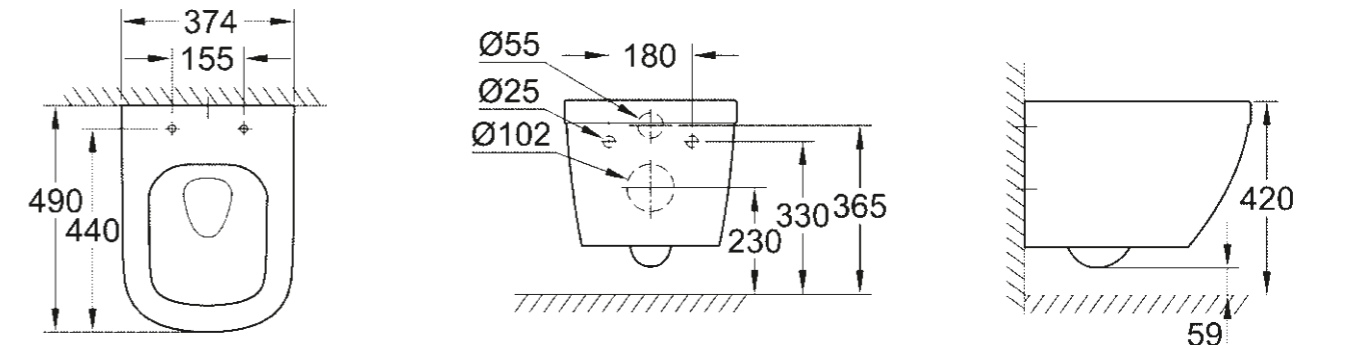

39 206 000
39 206 00H*
Compact wall hung WC
Triple Vortex

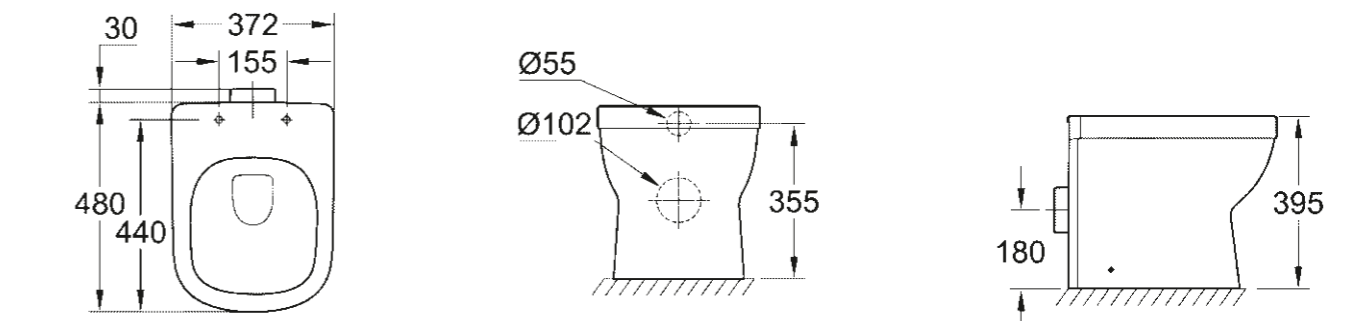

39 329 000
39 329 00H*
Floorstanding WC
rimless

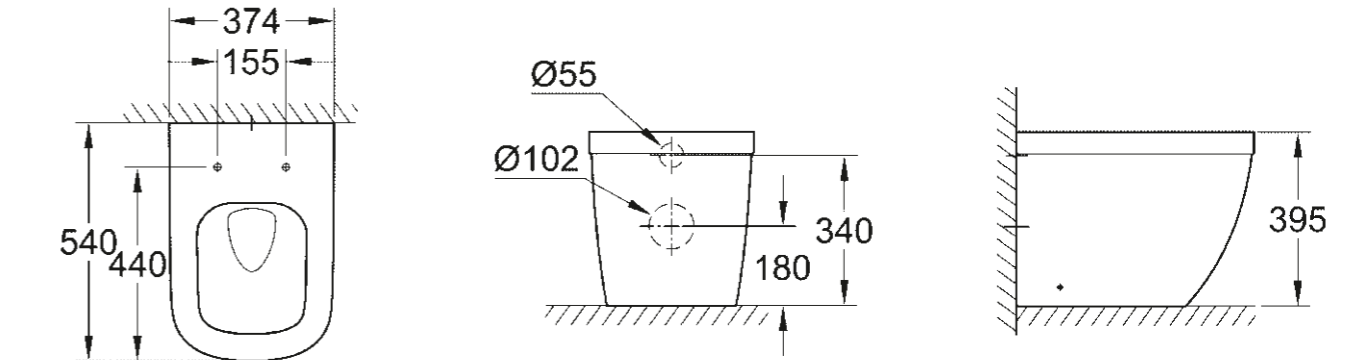

39 339 000
39 339 00H*
Floorstanding WC
back to wall
rimless



39 330 000
Seat & cover soft close
quick release function
39 331 000
w/o soft close

* With PureGuard

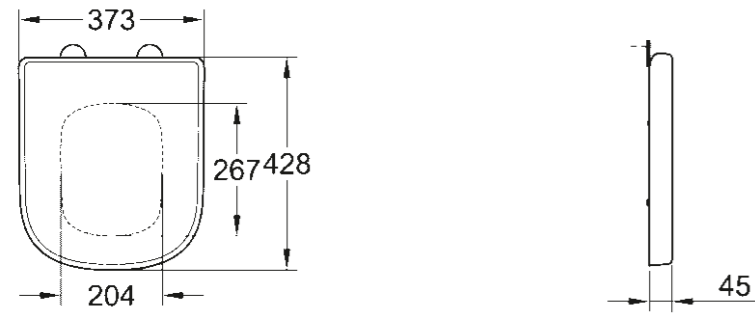

39 458 000
Seat & cover soft close for compact WC
quick release function
39 459 000
w/o soft close

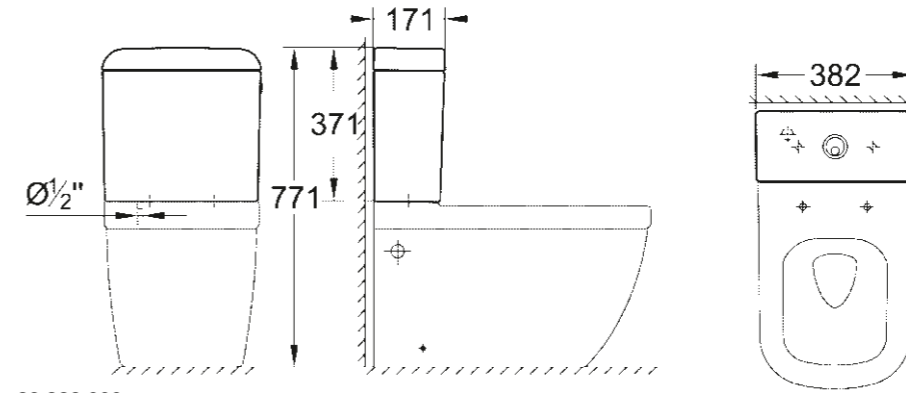

39 332 000
Cistern bottom inlet

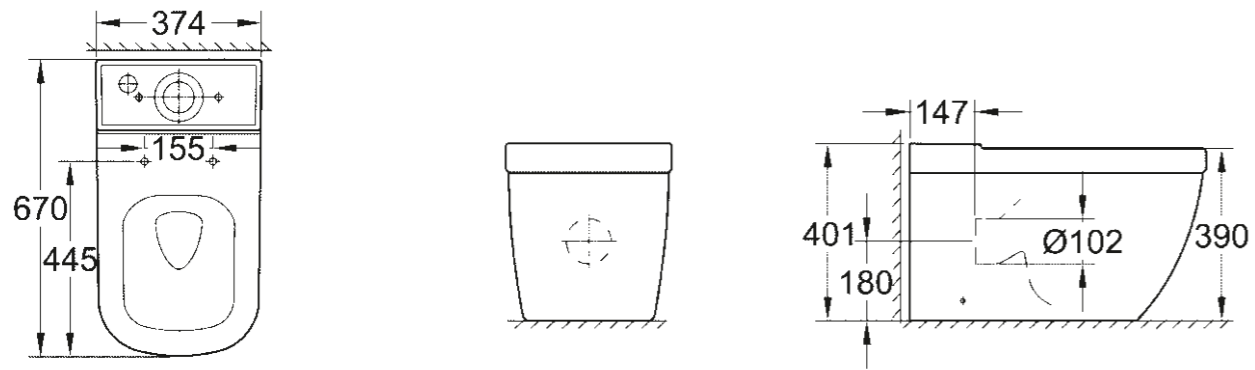

39 338 000
Floorstanding WC for closed coupled combination
Triple Vortex, universal outlet

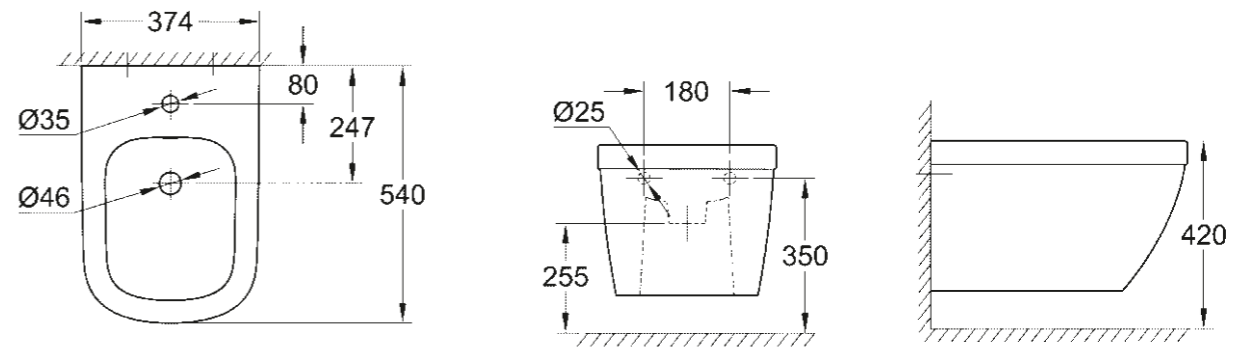

39 208 000
39 208 00H*
Wall hung bidet

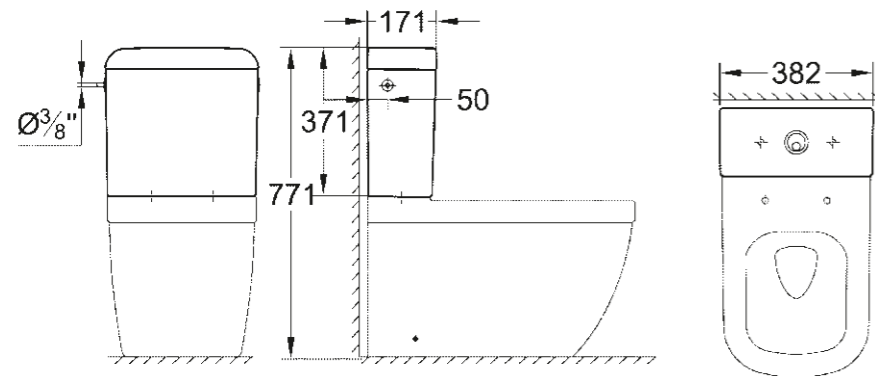

39 531 000
Cistern side and back inlet, NF

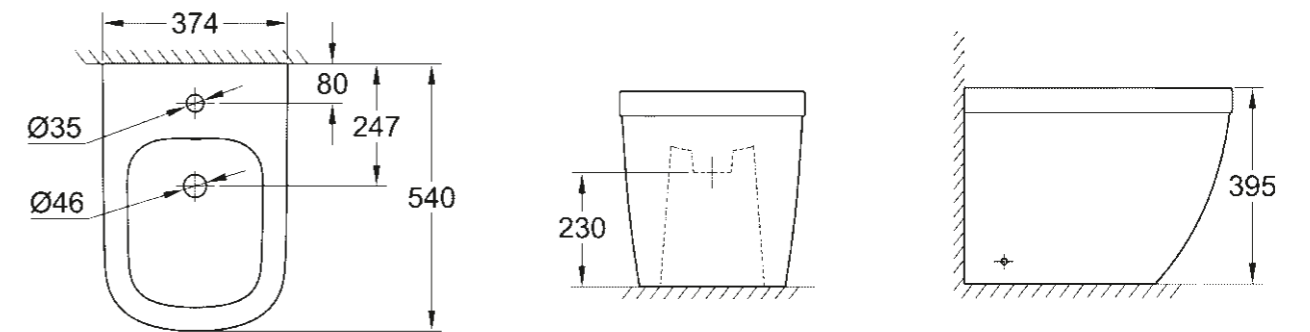

39 340 000
39 340 00H*
Floorstanding bidet

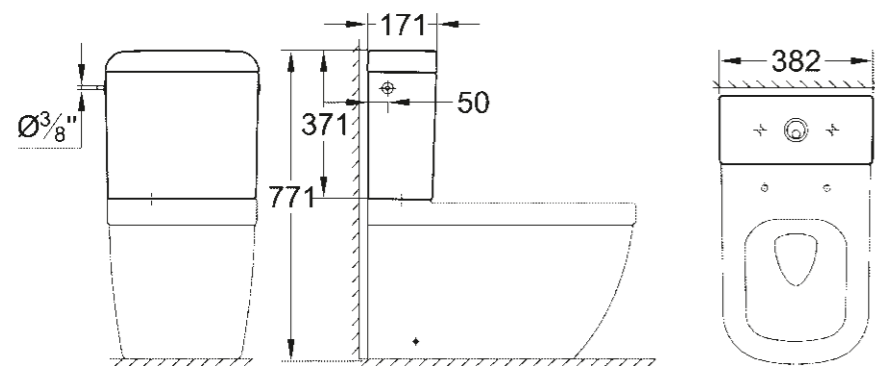

39 333 000
Cistern side and back inlet

* With PureGuard

CUBE CERAMIC

A CLEAR STYLE STATEMENT

WASHBASIN

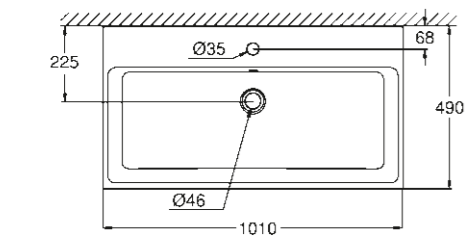

39 386 00H
Wall hung basin
100 cm

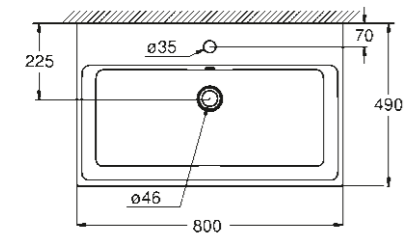
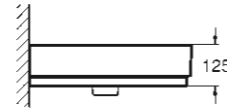
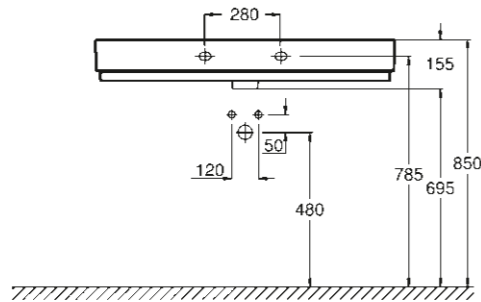

39 469 00H
Wall hung basin
80 cm

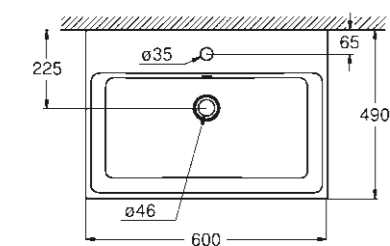
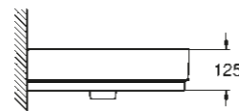
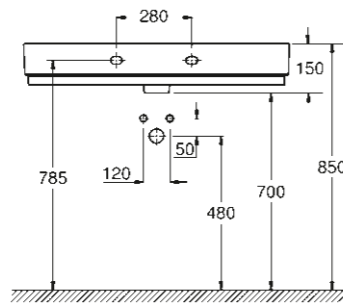

39 473 00H
Wall hung basin
60 cm

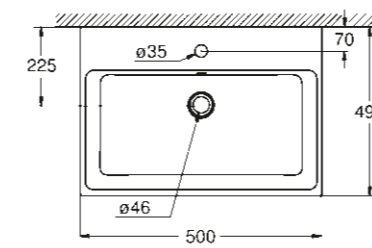
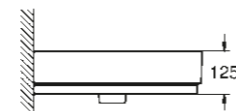
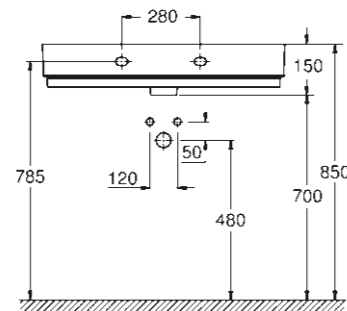

39 474 00H
Wall hung basin
50 cm

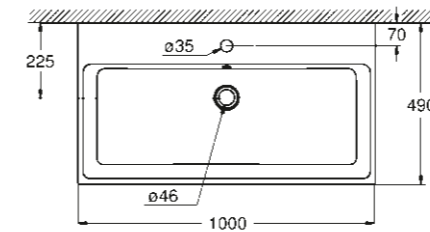
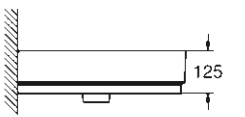
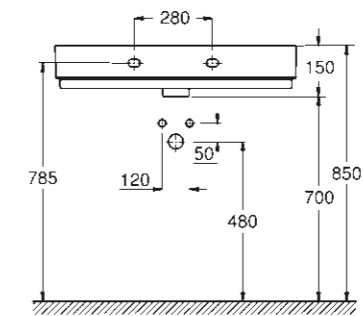

39 475 00H
Countertop basin
100 cm

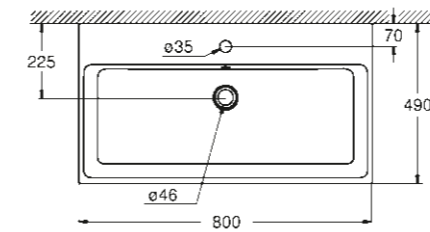
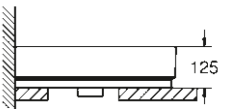
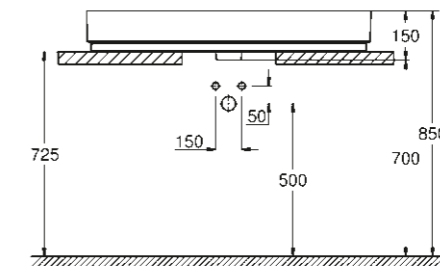

39 476 00H
Countertop basin
80 cm

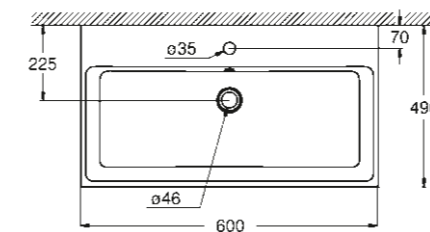
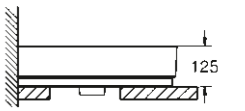
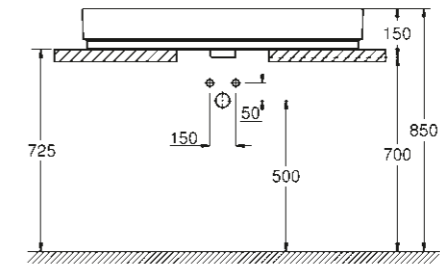

39 477 00H
Countertop basin
60 cm

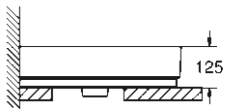
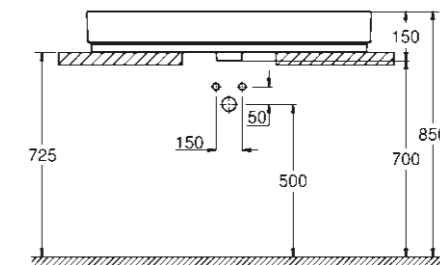

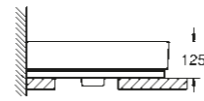
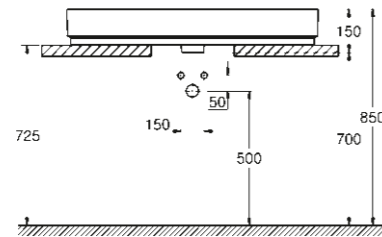
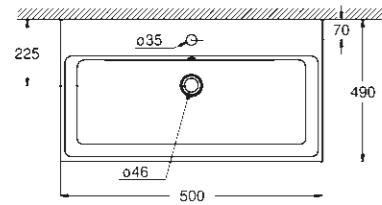

39 478 00H
Countertop basin
50 cm

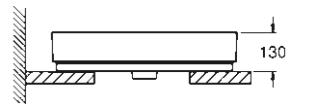
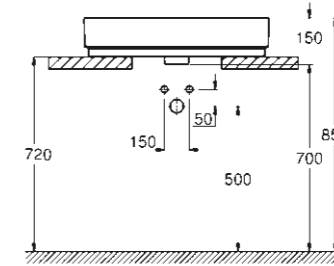
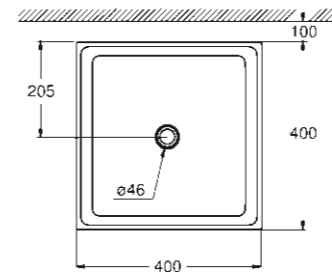

39 482 00H
Vessel basin
40 cm

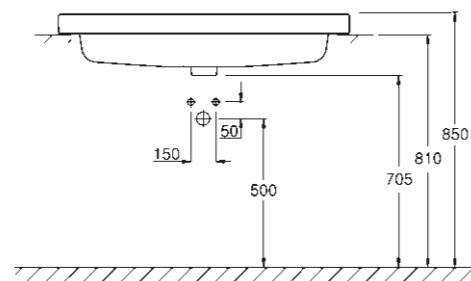
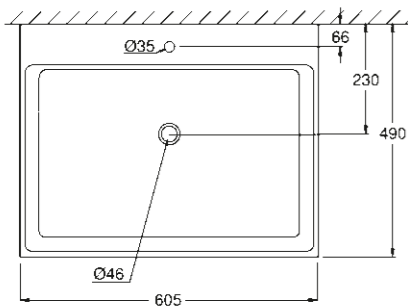

39 479 00H
Drop-in basin
60 cm

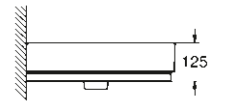
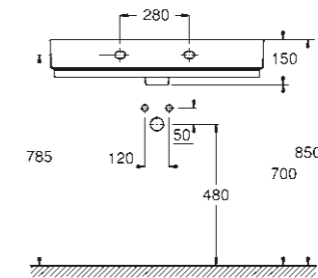
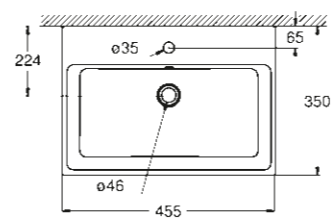

39 483 00H
Handrinse basin
45 cm

WC/BIDET

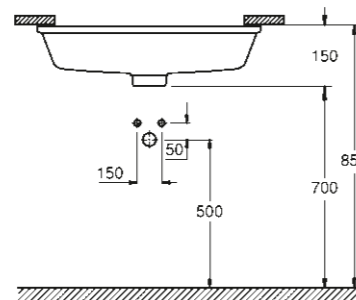
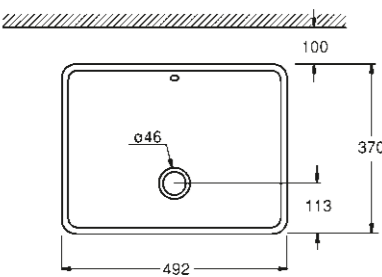

39 480 00H
Undercounter basin
50 cm

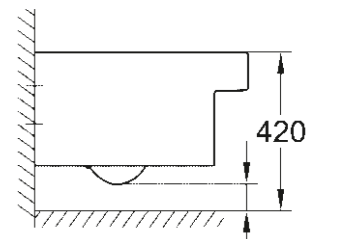
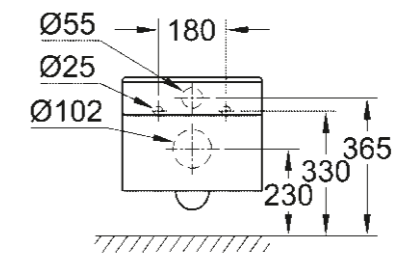
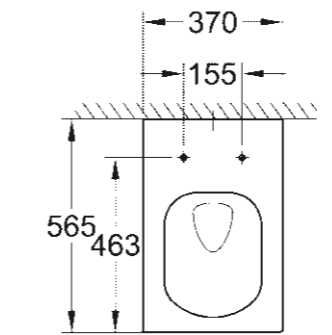

39 244 00H
Wall hung WC
Triple Vortex

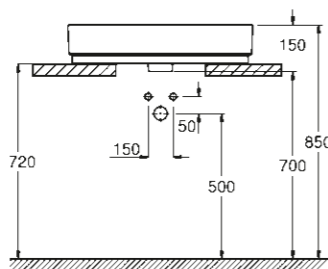
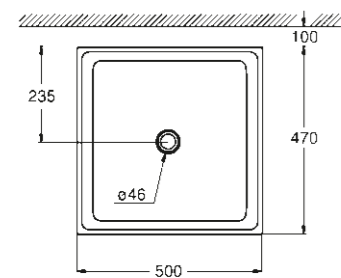

39 481 00H
Vessel basin
50 cm

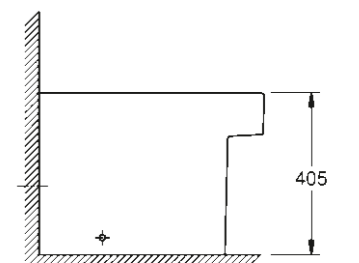
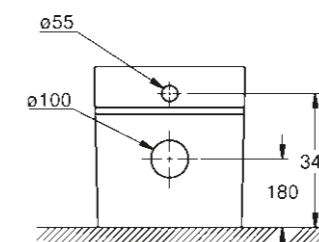
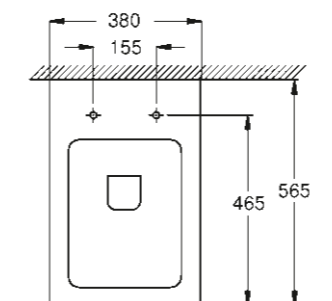
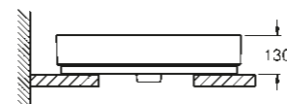

39 485 00H
Floorstanding WC back to wall
rimless

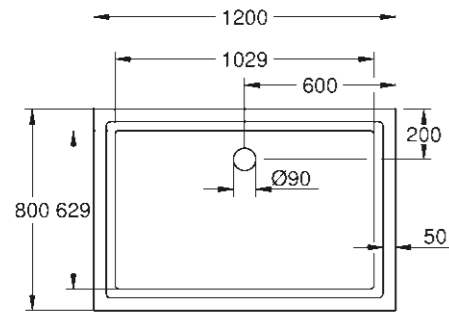

39 305 000*
Universal shower tray 80 cm x 120 cm

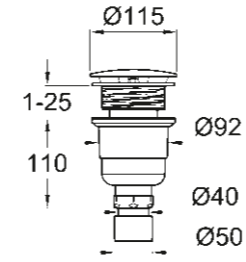
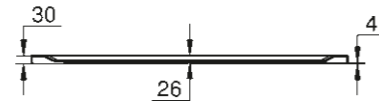

49 533 000*
Waste set vertical for Universal shower trays

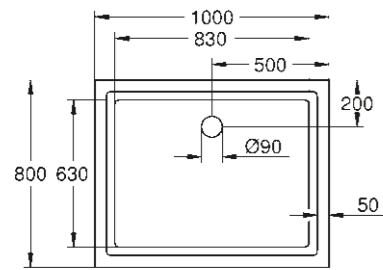

39 306 000*
Universal shower tray 80 cm x 100 cm

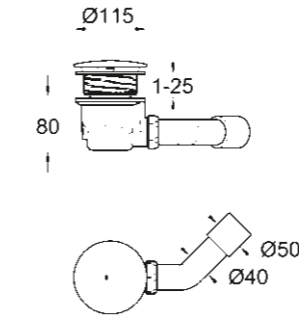
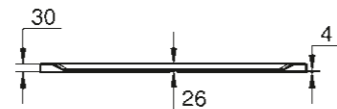

49 534 000*
Waste set horizontal for Universal shower trays

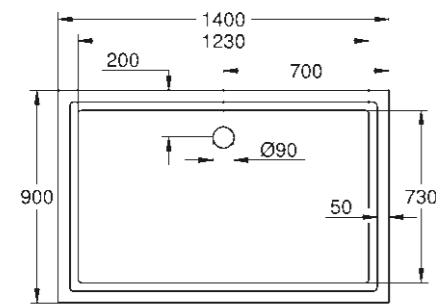

39 307 000*
Universal shower tray 90 cm x 140 cm

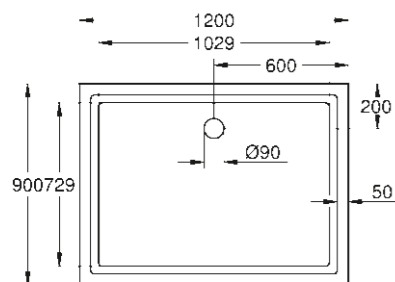
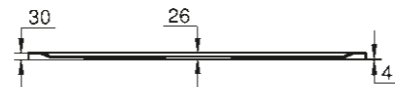

39 308 000*
Universal shower tray 90 cm x 120 cm

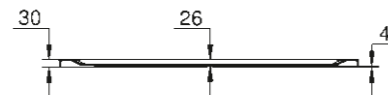

PURE FREUDE AN WASSER.

Life-giving, universal, joyful – water itself is the source of inspiration for the whole of our distinctive product portfolio.

Each of these products is always based on our four core values: Quality, Technology, Design and Sustainability. Balancing these in everything we do, allows us to deliver unrivalled water enjoyment to our customers.





QUALITY

GERMAN PERFECTIONISM INSPIRES ULTIMATE CUSTOMER CONFIDENCE.

We strive for an excellence that goes way beyond the surface of our products. In fact, from design to production and customer service we aim for nothing less than perfection at every stage. Our history of great German engineering, rigorous internal tests and numerous external certification processes are what gives our customers complete confidence in a name they can trust.



NO. 1 MOST TRUSTED BRAND BY CONSUMERS (IN THE SANITARY INDUSTRY)



TECHNOLOGY

MASTERING WATER THROUGH TECHNOLOGY.

In our relentless search for technological innovation we work to integrate the latest digital advances, creating smart solutions that enhance our customers' enjoyment of water. Our in-house experts harness the power of water to enhance the experience of our customers every day – the moment of truth, for our products and brand.



FORTUNE MAGAZINE: AMONG TOP 50 COMPANIES TO "CHANGE THE WORLD"



DESIGN

SIGNATURE ELEMENTS STYLED TO PERFECTION.

An empathetic and intuitive design language offers us the opportunity to create products that feel as if they were designed just for you. This unique GROHE DNA that is both ergonomic and visually distinctive has earned us numerous design awards: world class references are testimony to our world-wide recognition.

300+
DESIGN AWARDS

DESIGN AWARDS WON SINCE 2003

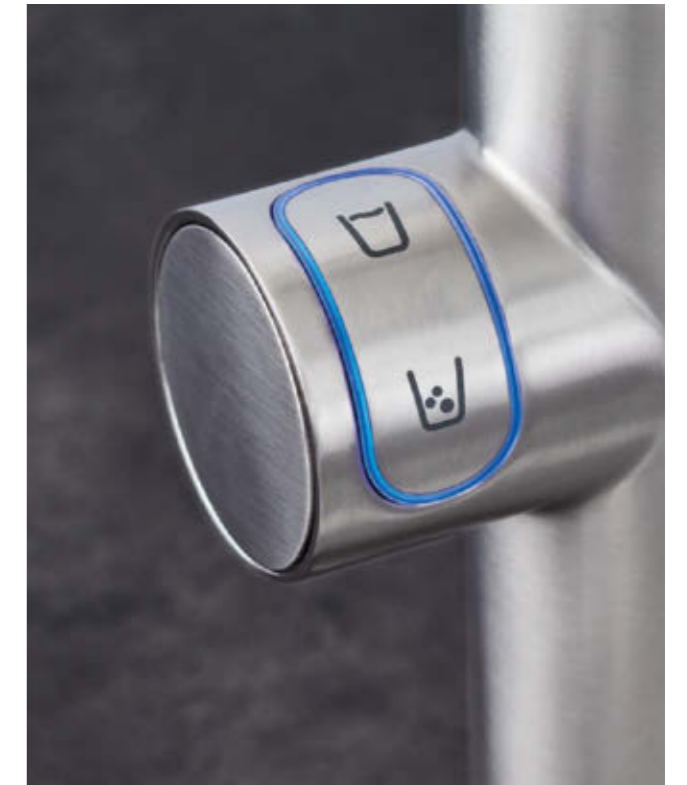

SUSTAINABILITY

ENSURING WATER ENJOYMENT FOR GENERATIONS TO COME.

Water is as essential as the air that we breathe, one more reason why we are so passionate about it. To be able to offer "Pure Freude an Wasser", not just to today's consumer but for generations to come, we offer sustainable product solutions like GROHE Blue, GROHE EcoJoy and GROHE SilkMove ES, and we demonstrate through our Sustainability Report and Sustainability accolades that we have made a serious corporate commitment to protecting the planet.



Winner 2017

CSR AWARD WINNER OF THE GERMAN GOVERNMENT

A GLOBALLY CONNECTED COMPANY

GROHE IS PART OF LIXIL – A GLOBAL LEADER IN THE HOUSING AND BUILDING INDUSTRY.

Beginning back in early 20th century Japan, LIXIL is today the most comprehensive company in our industry, with a unique portfolio spanning everything from technologies that revolutionize how we interact with water, to a full lineup of interior and exterior materials and products for houses and major architectural projects. Operating in 150 countries, LIXIL companies design and manufacture products that are used by more than a billion people around the world every day.

The world is changing rapidly, and LIXIL companies are helping to shape it. Across our brands and technologies, we design and manufacture tomorrow's living solutions, today. From developing smart innovations in people's homes and offices, to redefining the world's most famous city skylines, LIXIL products are transforming the spaces in which we all work, learn, travel, relax, and live.

Alongside GROHE in LIXIL's family of world-class brands are American Standard, INAX, DXV by American Standard and Permasteelisa.

Combined, our brands make us number one in faucets and plumbing-related products worldwide and Japan's premier provider of housing products. We're leading the way in many other areas around the world, thanks to our shared focus on creating innovations that genuinely improve people's lives.

Together we're stronger. Combining our GROHE expertise as a world leader in sanitary fittings with the unique technology and insights from LIXIL's other Water Technology brands, GROHE now offers complete bathroom solutions, featuring innovative products like shower toilets and SmartControl showers, alongside revolutionary technologies such as Triple Vortex sanitaryware that stays clean for 100 years. Beautiful, functional and reliable, LIXIL's products and solutions are changing the way people live, all over the world.

Together, we share a powerful vision of a better tomorrow, for our customers and for the world.

As a truly global manufacturing company, we know that we have an important part to play in securing the future of our planet. We're leading the way in areas such as energy efficiency and water saving technology and aim to achieve a net zero environmental footprint by 2030. We believe everyone should have access to clean and safe sanitation, and are committed to using our expertise to help make this possible.

Together we're creating the future of good living for everyone, everywhere.

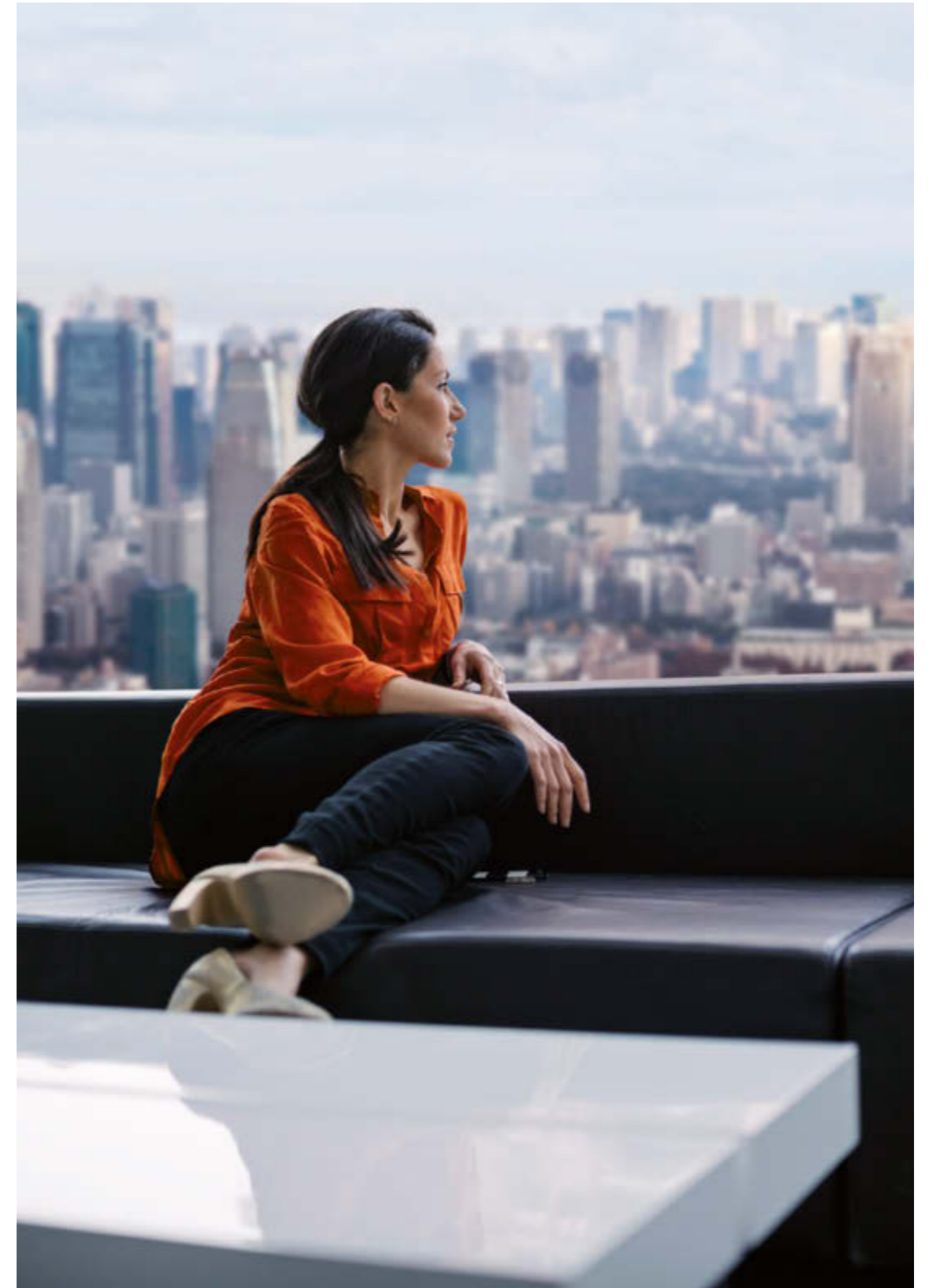

DISCOVER THE WORLD OF GROHE

What you see here represents just a small selection of what the world of GROHE has to offer. Whether you are looking for ideas and inspiration or solutions for bath and kitchen, here's where you'll find it.

Just scan the QR codes to view the latest brochures as download or PDF on your tablet or smart phone.

OR VISIT THE WORLD OF GROHE AT GROHE.COM



BATH BROCHURE

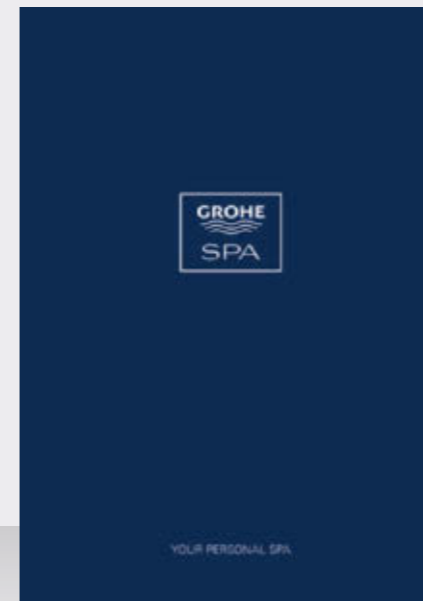

SPA BROCHURE



SENSIA ARENA BROCHURE

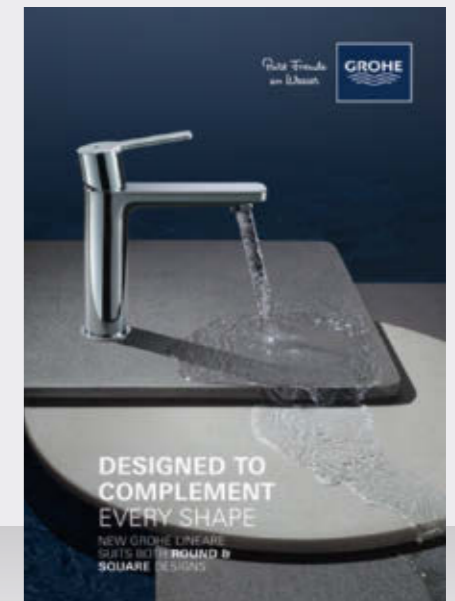

LINEARE BROCHURE



RAPIDO SMARTBOX BROCHURE



KITCHEN BROCHURE



SANITARY SYSTEMS BROCHURE



Follow us



QUALITY



TECHNOLOGY



DESIGN

300+
DESIGN AWARDS

SUSTAINABILITY



From FORTUNE, September 15, 2017, FORTUNE is a registered trademark of Time Inc., used under license. FORTUNE and Time Inc. are not affiliated with, and do not endorse products or services of, GROHE.



Just scan the QR code to view the latest brochure as download or PDF on your tablet or smartphone.

Grohe AG
Feldmühleplatz 15
D - 40545 Düsseldorf
Germany

© 02/2018 – Copyright by GROHE

PART OF **LIXIL**